



- Multifunction Meters
- Transducers & Isolators
- Temperature Controllers
- Converters & Recorders
- Digital Panel Meters
- Current Transformers
- Analogue Panel Meters
- Shunts
- Digital Multimeters
- Clamp Meters
- Insulation Testers

EARTH LEAKAGE RELAY-ELPR SMART & SMART+

SUBJECT TO CHANGE WITHOUT NOTICE
This datasheet superseded all previous versions – please keep for future reference

ELPR - SMART & SMART+



Product Features:

- Easy operation
- CBCT connection fault detection
- True RMS Measurement
- Programmable parameter through potentiometer
- Test and Reset Key
- Remote Reset
- LED indications
- Operation table LED
- Relay output
- DIP switch for settings (Smart version only)+

ELPR - Smart & Smart+

Sifam Tinsley ELPR is earth leakage relay (ELR), a protection device to be used in electrical installations against electric shock and / or damage to equipment caused by punctured or weak insulations or contact to live parts. Instrument operates by monitoring the earth leakage current through CBCT and disconnecting the circuit in case of hazardous levels of earth leakage currents. Sifam Tinsley ELPR is available in two versions, Smart and Smart+

Applications:

The application include Motor protection, Mining equipment, Industrial premises, Substation premises.

Product Features:

Easy operation: Front access potentiometer with marking are provided to set desired value of leakage current and trip time.

CBCT connection fault detection: CBCT connection at the device terminals is monitored so leakage detection is always faithful. PON LED indicates CBCT fault status.

True RMS Measurement The instrument measures distorted waveform up to 15th harmonic and categorized under Type A ELR.

Programmable parameter through potentiometer:

1. Leakage current: The measured leakage current value is continuously compared with this set value. Fault is condition said to occurred if leakage current exceeds this set value of current. (30mA, 100mA, 300mA, 500mA, 1A,3A, 5A, 10A, 20A or 30A programmable)

2. Trip Delay: The time in seconds for which fault leakage current should persist so that relay will be driven to fault state. Zero trip delay corresponds to instantaneous tripping. (0s, 0.06s, 0.15s, 0.25s, 0.5s, 0.8s, 1s, 2.5s, 5s, 10s programmable)

Test and Reset Key: Test Key - Pressing this key trigger the fault state operation of the device. Reset Key - Pressing this key trigger the Normal working state operation of the device. Reset will restore the normal operation of alarm and main relay only if leakage current is in normal range (Below reset value of leakage current of corresponding relay) reset operation has memory function till device is powered on Press timing for both keys is 3 seconds approximately.

Remote Reset: Two contacts are provided at terminal block, can be used for remote reset operation, These contact function are similar to reset key operation

LED indications:

1. Bar graph - Measured leakage current in terms of percentage of set leakage current (In), and indicated by 4 LED's as per 30%, 45%, 60%, 75% of set value.
2. PON - Indicates device is powered on and working. Additionally it shows CBCT fault condition by blinking
3. Trip - Indicates relay fault state.

Operation table LED:

1. PON LED ON - Device is powered on and functioning
2. PON LED Blinking - CBCT Open detected
3. Trip LED ON - Relay is in fault state
4. Trip LED blinking - Alarm relay is activated

Relay output:

1. Relay1: This is main ELR relay having 3 terminal (COM, NO, NC) to signal the fault condition. This relay is default normally de-energize in Smart version, whereas in advance version its configuration can be changed by DIP switch.
2. Relay2 (Optional): This is additional relay having 2 terminal (COM, NO). This relay function as alarm relay in Smart version and default normally de-energize. Alarm relay activates when leakage increase above 50% of set In value.

This relay can be configured as either fail safe relay or Alarm relay through DIP switch in Smart+ version.

DIP switch for settings (Smart version only)+

1. Auto Re-closure (Reset):

If enabled, device automatically resets the fault condition for pre-set time and measure leakage current so as to decide operating state of device. 3 attempts are made to reset fault.

Manual reset is disabled in this case.

2. Fail safe or Alarm Relay:

Configures additional 1 NO relay provided as either

Fail safe relay: Relay represents the state of power on condition and energized if power is applied.

Alarm relay: Relay is energized upon 50% of set leakage current is reached. Relay can be used to trigger devices for indication purpose or maintenance actions.

3. ELPR relay configuration:

Configures main relay state in either Energized or De-energized state.

Parameter Characteristics:

1. Reset Hysteresis: 15% of Trigger value (ELR , Alarm relay)
2. Power On, Reset Delay: Approx. 1 Second

Wide Auxiliary selection:

20-60 VDC / 20-40VAC, 60-300 VAC/VDC to suit all grid conditions.

Compliance to Standards:

EMC Compatibility: Compliance to International standard IEC 61326.

IEC 60947-2 : Annex - M

IEC60755 (Optional)

Safety standards: Compliance to International Safety standard IEC 61010-1- 2001

Mounting: Dinrail mount 2U flame retardant housing standard for universal Installations

Dimensions Details:

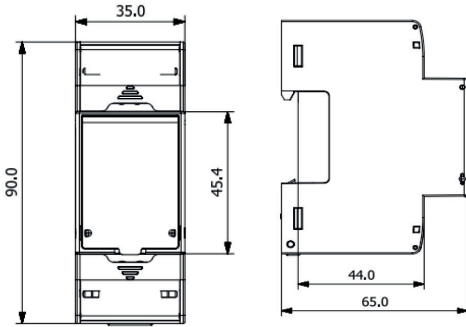

Terminal Details:

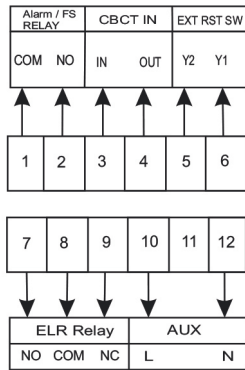

Connection Diagram:

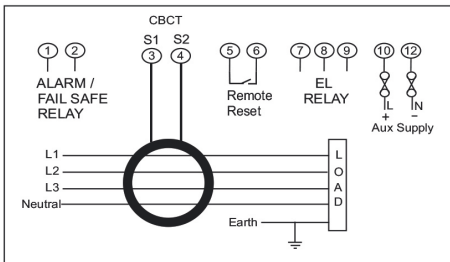

Technical Specifications:

Input characteristics:	
Leakage current (In)	30mA to 30A (Type A)
Tripping operating range	80 % to 100% of In
Alarm operating range	50 % of In
Resetting value	- 15 % of operating range
Auxiliary Supply:	
Auxiliary supply option1	60V-300V AC / DC
Auxiliary supply option 2	20-60V DC / (20-40 VAC)
Auxiliary supply frequency	45 to 66 Hz range
Auxiliary supply burden	< 4 VA approx.
Accuracy:	
Leakage current	+ 5% of full scale
Trip Delay (Including Setting Accuracy)	+ 5% of set trip time or 50ms (whichever is greater)
Instantaneous Trip function	< 25 millisecond for leakage current grater than 5 times (5x) set In*.
Reference Conditions for Accuracy:	
Reference temperature	23°C +/- 2°C
Input Waveform	Sinusoidal (distortion factor 0.005)
Input frequency	50/60 Hz ± 2%
Auxiliary supply voltage	230 ± 1%
Auxiliary supply frequency	50 or 60 Hz ±2%
Applicable Standards:	
EMC	IEC 61326-1:2012 Table2
Terms, definitions & Test method	IEC 60688
Immunity	IEC 61000-4-3 10 V/m Min - Level 3
Safety	IEC 61010-1-2001, Permanently connected use
IP for water & dust	IEC60529
Pollution degree	2
Installation category	III 300 V
High Voltage Test	2.2 kV AC, 50Hz for 1 minute between all electrical circuits
Environmental:	
Operating temperature	- 20 to + 65°C
Storage temperature	- 40 to + 70°C
Relative humidity	0... 90% (non condensing)
Shock (As per IEC60068-2-27)	Half sine wave, Peak acceleration 30 gn (300 m/s^2), duration 18ms.
Vibration	10... 150...10 Hz, 0.15mm amplitude
Number of Sweep cycles	10 per axis
Enclosure	IP40 (Front face) IP 20 (Terminals)
Relay Contacts:	
Relay 1 (ELR) output	1 NO + 1 NC (1 CO)
Relay 2 (Alarm / FS) output	1 NO
Contact rating	5A / 250 VAC or 30VDC
Mechanical endurance	1 x 10^7 OPS
Electrical endurance	5 x 10^4 OPS (Resistive Load)
Remote Reset:	
Operation:	Non potential free (Voltage level 12 VDC Approx.), Isolated contacts for remote resetting of ELR and alarm relay.
Mechanical:	
Housing dimensions:	90 x 65 x 35 mm As per DIN 43880
Weight	125 Gram Approx.

*Note : 5x current measurement not applicable for 30A range

Ordering Information:

Product Code	ELR2 - XX - X - XX - 00000000
Earth Leakage Relay POT	
Auxiliary Supply: L - 20 - 60 DC / 20 - 40 AC M - 60 - 300 AC / DC	
Model and Additional Outputs: BZ - Smart BR - Smart with Alarm Relay AR - Smart+* with 1 NO Relay Output	

* Smart+ model with DIP switch. Following configurations possible through DIP switch.

1. Auto-reclosure (Reset) or manual reset selection for reset of relay when currents are normal after fault condition is removed
2. Configuration option of 1 NO relay (Alarm Relay or Fail Safe Relay)
3. Main Relay configuration as Energized or De-energised

Note:

1. Energized configuration: Relay Pole and NO contacts become energized (ON) upon fault.
2. De-Energized configuration: Relay Pole and NO contacts become De-energized (OFF) upon fault.