



ND31 LITE

POWER NETWORK METER

WITH MODBUS RTU PROTOCOL (RS-485)

FEATURES

- **Measurement** of 54 power network parameters, including **current and voltage harmonics up to 63rd** in 1-phase 2-wire or 3-phase 3- or 4-wire balanced and unbalanced systems.
- **High accuracy class (0.2S for active energy).**
- **Graphical color display:** LCD TFT 3,5", 320 x 240 pixels, **fully configurable by a user** (10 screens, 8 parameters in each).
- **Additional 2 screens for harmonics presentation and 1 dedicated screen for visualization in the form of an analog meter.**
- Indications include the values of programmed ratios.
- Memory of minimum and maximum values.
- 2 configurable alarm outputs.
- Supervisory relay mode for alarm outputs.
- Programming of parameters using **free eCon software.**
- Battery backup RTC.
- Overall dimensions: 96 x 96 x 77 mm.

FEATURES



INPUTS



OUTPUTS



GALVANIC ISOLATION

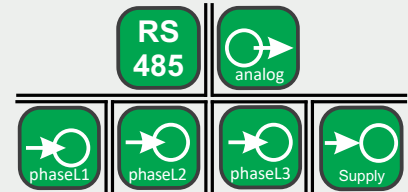

EXAMPLE OF APPLICATION

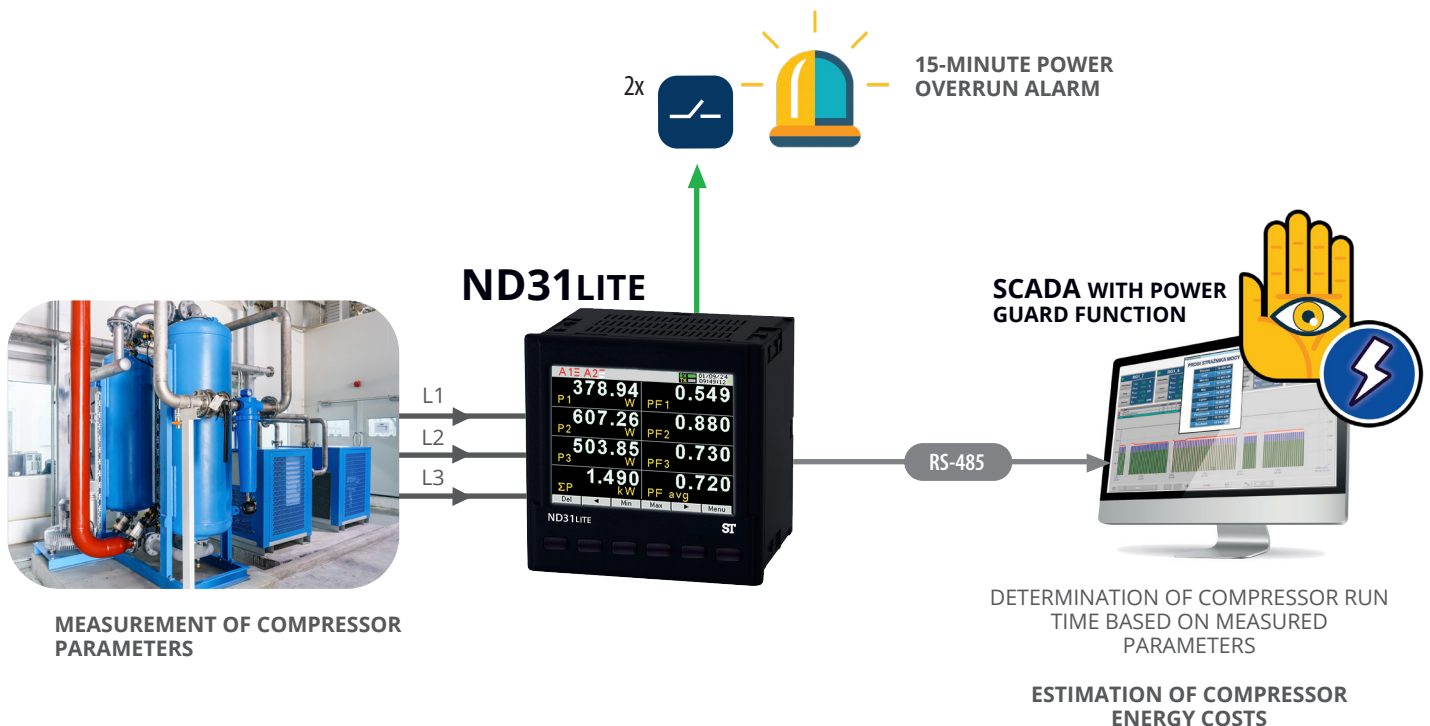

MEASUREMENT AND VISUALIZATION OF POWER NETWORK PARAMETERS

- phase voltages: U_1, U_2, U_3
- phase-to-phase voltages: U_{12}, U_{23}, U_{31}
- phase currents I_1, I_2, I_3
- active phase powers: P_1, P_2, P_3
- reactive phase powers: Q_1, Q_2, Q_3
- apparent phase powers: S_1, S_2, S_3
- active power factors: PF_1, PF_2, PF_3
- reactive/active power factors: $tg\phi_1, tg\phi_2, tg\phi_3$
- active, reactive and apparent 3-phase power: P, Q, S
- mean 3-phase power factors: $PF, tg\phi$
- frequency f
- mean 3-phase voltage: U_s
- mean phase-to-phase voltage: U_{mf}
- mean 3-phase current: I_s
- 15, 30, 60 minutes' mean active power: P_{demand}
- mean apparent power S_{demand}
- average current I_{demand}
- active, reactive and apparent 3-phase energy: EnP, EnQ, EnS
- active, reactive and apparent energy from external counter: $EnPE$
- total harmonic content coefficients for phase voltages and currents $THD_{U1}, THD_{U2}, THD_{U3}, THD_{I1}, THD_{I2}, THD_{I3}$ and for 3-phase voltages and currents THD_U, THD_I
- harmonics for current and phase voltage up to 63rd!

TECHNICAL DATA

MEASURING RANGE

Measured value	Measuring range	L1	L2	L3	Σ	Class
Current 1/S A 1 A~ 5 A~	0.002 ..0.100..1.200 A 0.010 ..0.500.. 6.000 A ...100.00 kA (tr _I ≠1)	•	•	•		0.2 (EN 61557-12)
Voltage L-N 57.7V~ 110V~ 230V~ 400V~	5.700..11.500 ..70.000 V 11.000..22.000 ..132.000 V 23.000..46.000 .. 276.000 V 40.000..80.000 .. 480.000 V ...1920.0 kV	•	•	•		0.2 (EN 61557-12)
Voltage L-L 100V~ 190V~ 400V~ 690V~	10.000 ..20.000..120.00 V 19.000 ..38.000..228.00 V 40.000..80.00 .. 480.00 V 69.000..138.00 .. 830.00 V ...1999.0 kV (tr _U ≠1)	•	•	•		0.5 (EN 61557-12)
Active power P	-19999 MW .. 0,000 W19999 MW (tr _U ≠1, tr _I ≠1)	•	•	•	•	0.5 (EN 61557-12)
Reactive power Q	-19999 MVar .. 0,000 Var19999 MVar (tr _U ≠1, tr _I ≠1)	•	•	•	•	1 (EN 61557-12)
Apparent power S	0.000 .. 1999,9 VA19999 MVA (tr _U ≠1, tr _I ≠1)	•	•	•	•	0.5 (EN 61557-12)
Active energy EnP (imported or exported)	0.000 .. 99 999 999.999 kWh				•	0.2S (EN 62053-22)
Reactive energy EnQ (inductive or capacitive)	0.000 .. 99 999 999.999 kVarh				•	1 (EN 61557-12)
Apparent energy EnS	0.000 .. 99 999 999.999 kVAh				•	0.5 (EN 61557-12)
Active power factor PF	-1.00 ..0 ..1.00	•	•	•	•	1 (EN 61557-12)
Factor tg (ratio of reactive power to active power)	-999.99...-1.20 .. 0 .. 1.20...999.99	•	•	•	•	1
Frequency f	45.000...65.000...100.000 Hz				•	0.1 (EN 61557-12)
Total harmonic distortion of voltage THDU and current THDI	0.0 ..100.0 %	•	•	•	•	5 (EN 61557-12)
Amplitudes of the voltage $U_{h2}...U_{h63}$ and current $I_{h2} ... I_{h63}$	0.0 ..100.0 %	•	•	•		II (IEC61000-4-7)

tr_I - Current transformer ratio = CT primary current / CT secondary current
tr_U - Voltage transformer ratio = VT primary voltage / VT secondary voltage

DIGITAL INTERFACE

Interface type	Transmission protocol		Remarks
RS-485	Modbus RTU 8N2,8E1,8O1,8N1	Address 1..247	baud rate: 4.8, 9.6, 19.2 38.4, 57.6, 115.2 kbit/s

EXTERNAL FEATURES

Readout field	graphic color display LCD TFT 3,5", 320 x 240 pixels	
Overall dimensions	96 x 96 x 77 mm	mounting hole 92.5 x 92.5 mm
Weight	0.3 kg	
Protection grade	from frontal side: IP65	from terminal side: IP20

RATED OPERATING CONDITIONS

Supply voltage	→ 85...253 V a.c. (40...50...400 Hz), 90...300 V d.c.	power consumption ≤ 6 VA
Power consumption	in voltage circuit ≤ 0.5 VA	in current circuit ≤ 0.1 VA
Input signal	0...0.1...1.2 In; 0.1...0.2...1.2 Un for current, voltage, PF, tgφ	frequency 45...50...60...100 Hz, sinusoidal (THD ≤ 8%)
Power factor	-1...0...1	
Preheating time	15 min.	
Ambient temperature	-10...23...55°C	class K55 acc. to EN61557-12
Humidity	0...40...60...95%	without condensation
Operating position	any	
External magnetic field	≤ 40...400 A/m d.c.	≤ 3 A/m a.c. 50/60 Hz
Short-term overload	voltage input: 2 Un (5 sec.)	current input 50 A (1 sec.)
Admissible crest factor	current: 2	voltage: 2
Additional error (in % of the intrinsic error)		from ambient temperature change: < 50% / 10°C

SAFETY AND COMPATIBILITY REQUIREMENTS

Electromagnetic compatibility	noise immunity	acc. to EN 61000-6-2, EN IEC 61326-1
	radio-frequency common mode: • level 2: 0,15...1 MHz • level 3: 1 MHz...80 MHz	
Isolation between circuits	basic	acc. to EN 61000-6-4, EN IEC 61326-1 acc. to EN 61010-1
Pollution level	2	acc. to EN 61010-1
Overvoltage category OVC	III	for voltage to earth up to 300V
Maximal phase-to-earth voltage	• for supply circuit and relay outputs 300 V • for measuring input 500 V • for circuits of RS-485: 50 V	acc. to EN 61010-1
Altitude a.s.l.	< 2000 m	

CONNECTION DIAGRAMS

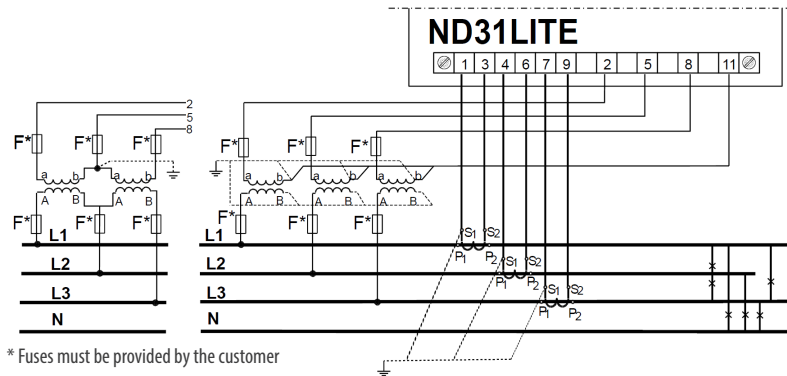
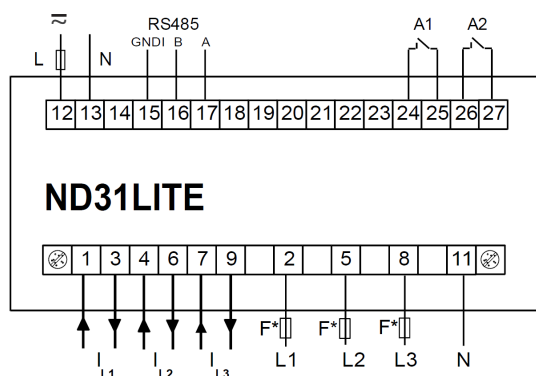

* Fuses must be provided by the customer

* Fuses must be provided by the customer

Description of meter connections strips

Indirect measurement in 4-wire network - connection of input signals

DISPLAING OF MEASUREMENT PARAMETERS

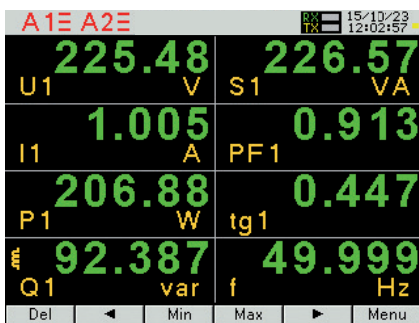

up to 10 programmable screens
(8 parameters per page);
ability to change color for all screens

Available colors for digital indications:

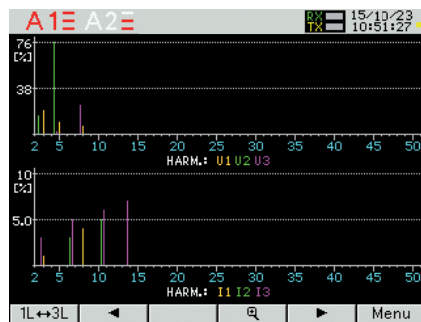
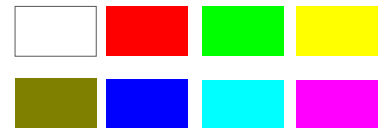

two screens dedicated to harmonics;
indication of individual harmonic
for voltages and currents (up to 51st);
bargraph presentation for all harmonics
with zoom function



presentation in the form of analog
meter view with min/max preview
for display value and zoom function

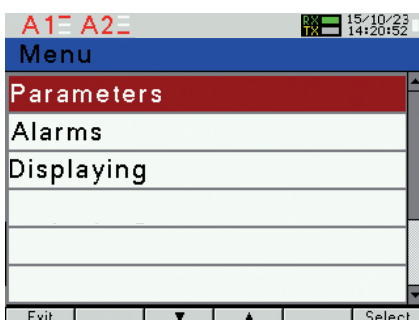

easy to use and intuitive menu;
information bar with status of:
phase sequence, alarm outputs,
RS-485 interfaces, time and date

METER CONFIGURATION WITH FREE eCON SOFTWARE

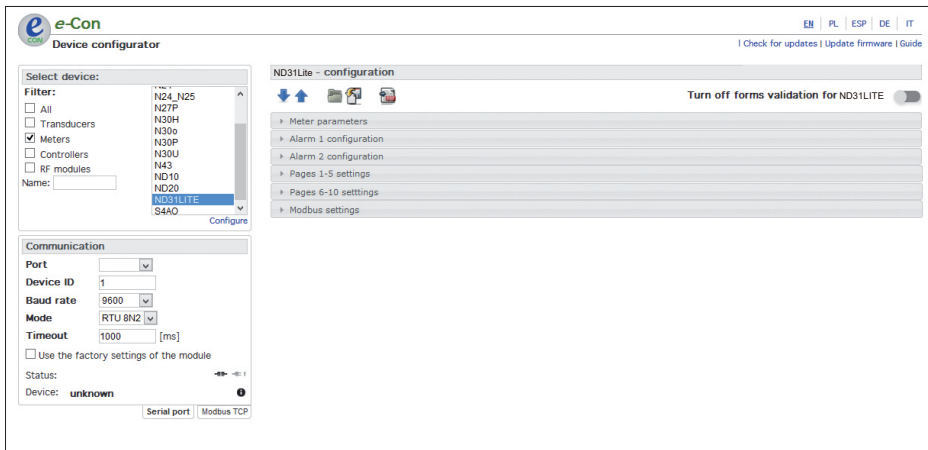

ability to configure and update ND31LITE with free eCon software (via RS-485 interface)

ORDERING CODE

Meter ND31LITE	1	1	1	1	X	X	XXXX
Input voltage (phase/phase-to-phase) Un:							
3 x 57.7/ 100 V, 3x 230/ 400 V	1						
Outputs /inputs:							
2 relays		1					
Interface:							
RS-485			1				
Supply:							
85...253 V a.c., 90...300 V d.c.				1			
Language:							
Polish/ English					M		
other*					X		
Acceptance tests:							
without additional quality requirements						0	
with an extra quality inspection certificate						1	
with an extra calibration certificate						2	
acc.to customer's request*						X	
Version:							
standard							
custom-made*							XXXX

ORDERING EXAMPLE: The code **ND31LITE 1111M0** means:
ND31LITE – ND31LITE meter,
1 – input voltage 3 x 57.7/100 V, 3 x 230/400 V,
1 – 2 relays,
1 – interface RS-485
1 – supply 85..253 V a.c., 90..300 V d.c.
M – Polish/English version,
0 – without additional quality requirements,
 – standard version.

* only after agreeing with the manufacturer