



- Multifunction Meters
- Transducers & Isolators
- Temperature Controllers
- Converters & Recorders
- Digital Panel Meters
- Current Transformers
- kWh Energy Meters
- Analogue Panel Meters
- Shunts
- Digital Bargraphs
- Digital Multimeters
- Protection Relays
- Synchroscope Series
- Rotary Switches
- Power Supplies
- Test & Measurement

OMEGA 10 SERIES SPLIT CORE CURRENT TRANSFORMERS

SUBJECT TO CHANGE WITHOUT NOTICE

This datasheet superseded all previous versions – please keep for future reference

OMEGA Split Core

OMEGA 10

Omega series split core transformers offer a cost effective and efficient method by which the current can be measured without the need to break the conductor, thereby reducing installation and commissioning time.

Specifications

- Primary current 100A to 5000A
- Secondary current 1A or 5A
- System voltage 720V (0.72kV) maximum
- Test voltage 3kV for 1 minute
- System frequency 50 or 60 Hz
- Insulation class E
- Overload withstand 1.2 times rated current continuously
- Short circuit thermal 60 x rated primary for 1 second
- Operating temperature 20°C to 70°C
- Relative humidity 0-90% (non condensing)
- Compliant with EN 60044-1 / IEC 61869-1
- Accuracy Class 3, 1 & 0.5
- Rated dynamic current = 2.55 x 1ht
- Enclosure Flame retardant grade classified UL 94V-O

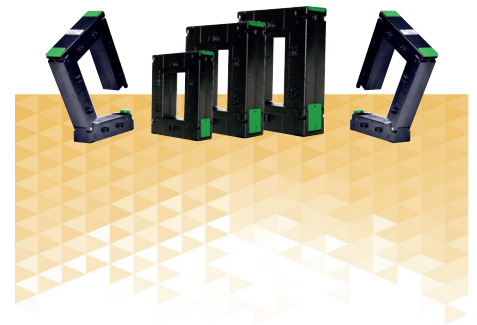

Features

- Compliant with EN 60044-1 / IEC 61869-1
- Flame retardant grade enclosure (UL 94V-O)
- Operation free installation
- Test voltage 3kV 50Hz 1min.
- System voltage 720V max.
- Ratio ratings from 100/5A to 5000/5A
- Available in 0.5, 1 and 3 accuracy class
- Insulation class: E
- UL approved

OMEGA 10

Technical Information (Ref: IEC 61869-2)

Limits of Current Errors and Phase Displacements for Measuring Current Transformers (Classes from 0.1 to 1)												
Accuracy Class	± Percentage Current (ratio) Error at Percentage of Rated Current shown below				± Phase Displacements at Percentage of Rated Current							
					Minutes				Centiradius			
	5	20	100	120	5	20	100	120	5	20	100	120
0.2	0.75	0.35	0.20	0.20	30	15	10	10	0.90	0.45	0.30	0.30
0.5	1.50	0.75	0.50	0.50	90	45	30	30	2.70	1.35	0.90	0.90
1.0	3.00	1.50	1.00	1.00	180	90	60	60	5.40	2.70	1.80	1.80

OMEGA 10A (93mm wide x 40mm deep x (33mm x 23mm) I.D.)

Cat No.	Ratio	VA at CL 1.0	Cat No.	Ratio	VA at CL 1.0
XS01-185031S000000	100/5A	1.5VA	XS01-275071S000000	250/5A	3.75VA
XS01-225221S000000	150/5A	1.75VA	XS01-285081S000000	300/5A	5VA
XS01-245051S000000	200/5A	2.5VA	XS01-315091S000000	400/5A	6.25VA

Note Class 0.5 possible on ratio's 300 and 400 amps

Dimensions

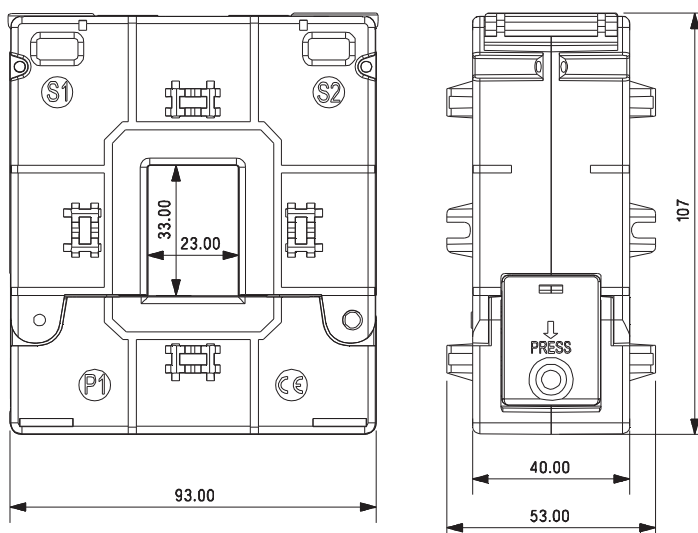

OMEGA 10A



OMEGA 10B

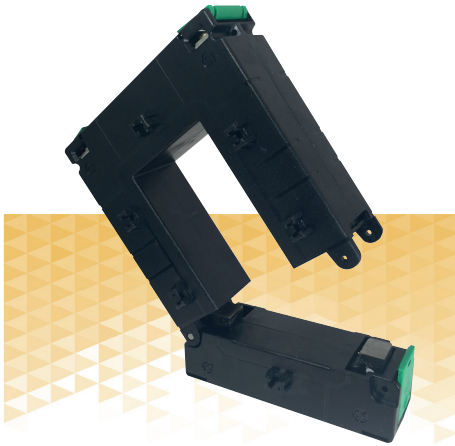

OMEGA 10B (125mm wide x 40mm deep x (50mm x 80mm) I.D.)

Cat No.	Ratio	VA at CL 0.5
XS02-275015S000000	250/5A	1VA
XS02-285055S000000	300/5A	2.5VA
XS02-315055S000000	400/5A	2.5VA
XS02-325075S000000	500/5A	3.75VA
XS02-335085S000000	600/5A	5VA
XS02-375105S000000	800/5A	7.5VA
XS02-395115S000000	1000/5A	10VA
XS02-405115S000000	1200/5A	10VA
XS02-415115S000000	1250/5A	10VA
XS02-425115S000000	1500/5A	10VA
XS02-435115S000000	1600/5A	10VA
XS02-445115S000000	2000/5A	10VA

Cat No.	Ratio	VA at CL 1.0
XS02-275051S000000	250/5A	2.5VA
XS02-285071S000000	300/5A	3.75VA
XS02-315071S000000	400/5A	3.75VA
XS02-325081S000000	500/5A	5VA
XS02-335101S000000	600/5A	7.5VA
XS02-375111S000000	800/5A	10VA
XS02-395131S000000	1000/5A	15VA
XS02-405131S000000	1200/5A	15VA
XS02-415131S000000	1250/5A	15VA
XS02-425131S000000	1500/5A	15VA
XS02-435131S000000	1600/5A	15VA
XS02-445131S000000	2000/5A	15VA

Dimensions

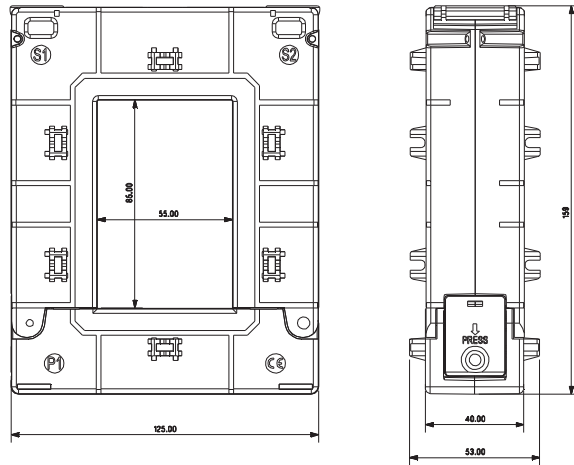

OMEGA 10C

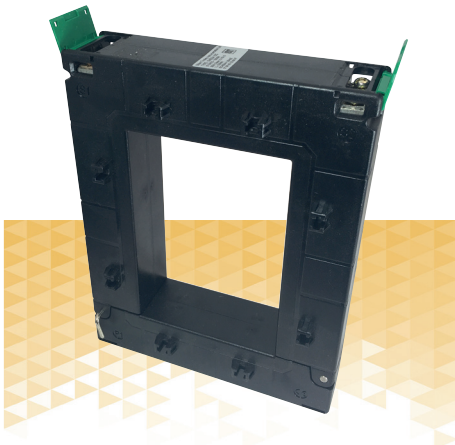

OMEGA 10C (155mm wide x 40mm deep x (120mm x 80mm) I.D.)

Cat No.	Ratio	VA at CL 0.5
XS03-335085S000000	600/5A	5VA
XS03-375105S000000	800/5A	7.5VA
XS03-395115S000000	1000/5A	10VA
XS03-405135S000000	1200/5A	15VA
XS03-415135S000000	1250/5A	15VA
XS03-425145S000000	1500/5A	20VA
XS03-435145S000000	1600/5A	20VA
XS03-445145S000000	2000/5A	20VA
XS03-465205S000000	2500/5A	25VA
XS03-485155S000000	3000/5A	30VA

Cat No.	Ratio	VA at CL 1.0
XS03-335105S000000	600/5A	7.5VA
XS03-375111S000000	800/5A	10VA
XS03-395131S000000	1000/5A	15VA
XS03-405151S000000	1200/5A	30VA
XS03-415151S000000	1250/5A	30VA
XS03-425161S000000	1500/5A	45VA
XS03-435161S000000	1600/5A	45VA
XS03-445161S000000	2000/5A	45VA
XS03-465161S000000	2500/5A	45VA
XS03-485161S000000	3000/5A	45VA

Dimensions

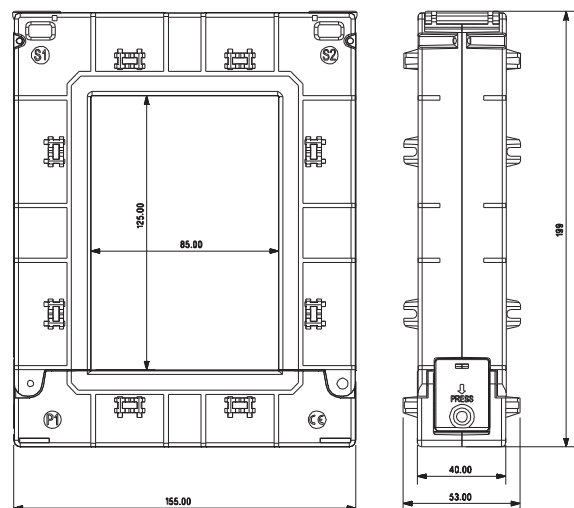

All dimensions are in mm

OMEGA 10D (195mm wide x 64mm deep x (80mm x 160mm) I.D.)

Cat No.	Ratio	VA at CL 0.5
XS04-395115S000000	1000/5A	10VA
XS04-405135S000000	1200/5A	15VA
XS04-415135S000000	1250/5A	15VA
XS04-425145S000000	1500/5A	20VA
XS04-435145S000000	1600/5A	20VA
XS04-445205S000000	2000/5A	25VA
XS04-465205S000000	2500/5A	25VA
XS04-485155S000000	3000/5A	30VA
XS04-515155S000000	4000/5A	30VA
XS04-525155S000000	5000/5A	30VA

Cat No.	Ratio	VA at CL 1.0
XS04-395141S000000	1000/5A	20VA
XS04-405141S000000	1200/5A	20VA
XS04-415141S000000	1250/5A	20VA
XS04-425151S000000	1500/5A	30VA
XS04-435151S000000	1600/5A	30VA
XS04-445151S000000	2000/5A	30VA
XS04-465151S000000	2500/5A	30VA
XS04-485161S000000	3000/5A	45VA
XS04-515161S000000	4000/5A	45VA
XS04-525161S000000	5000/5A	45VA

OMEGA 10D



Dimensions

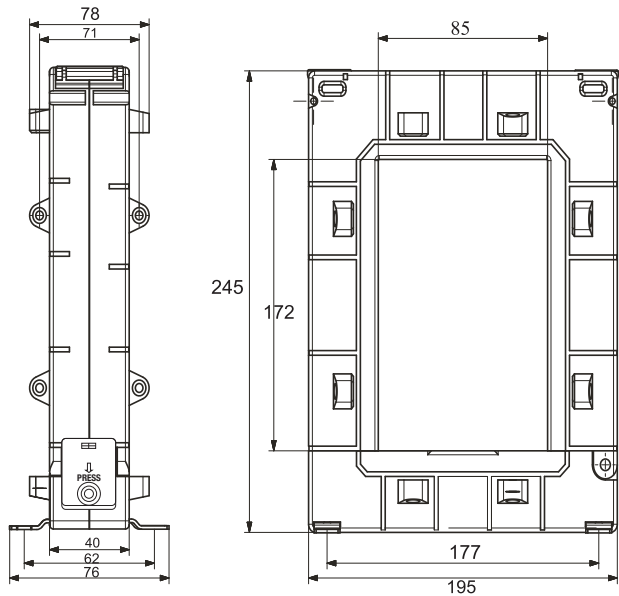

OMEGA 10E

OMEGA 10E (105mm wide x 50mm deep x (55mm x 43mm) I.D.)

Cat No.	Ratio	VA at CL 0.5
XS05-245035S000000	200/5A	1.5VA
XS05-275055S000000	250/5A	2.5VA
XS05-285055S000000	300/5A	2.5VA
XS05-315085S000000	400/5A	5.0VA
XS05-325085S000000	500/5A	5.0VA
XS05-335095S000000	600/5A	6.25VA
XS05-375105S000000	800/5A	7.5VA

Cat No.	Ratio	VA at CL 1.0
XS05-245071S000000	200/5A	3.75VA
XS05-275081S000000	250/5A	5VA
XS05-285081S000000	300/5A	5VA
XS05-315101S000000	400/5A	7.5VA
XS05-325101S000000	500/5A	7.5VA
XS05-335111S000000	600/5A	10VA
XS05-375121S000000	800/5A	12.5VA



Dimensions

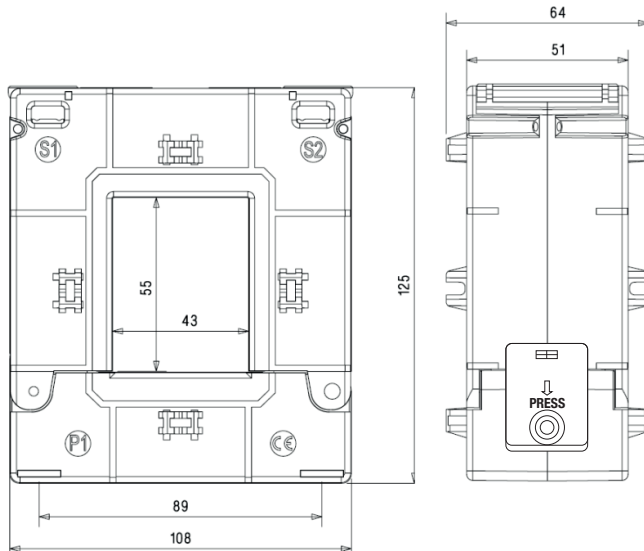

OMEGA Split Core with Class 0.5S accuracy

OMEGA 10

Omega series split core transformers offer a cost effective and efficient method by which the current can be measured without the need to break the conductor, thereby reducing installation and commissioning time. These high accuracy 0.5S versions means that the measurement has an error rate of 0.5% over a range of 20 to 120% of the nominal current (I_n) and at a specific accuracy above 1% of I_n (as per table given below)

Specifications

- Primary current 400A-4000A
- Secondary current 1 A or 5A
- System voltage 720V (0. 72kV) maximum
- Test voltage 3kV for 1 minute
- System frequency 50 or 60 Hz
- Insulation class E
- Overload withstand 1.2 times rated current continuously
- Short circuit thermal 60 x rated primary for 1 second
- Operating temperature 20°C to 70°C
- Relative humidity 0-90% (non condensing)
- Compliant with EN 60044-1 / IEC 61869-1 Accuracy Class 0.5S
- Rated dynamic current = 2.55 x 1 ht
- Enclosure Flame retardant grade classified UL 94V-O

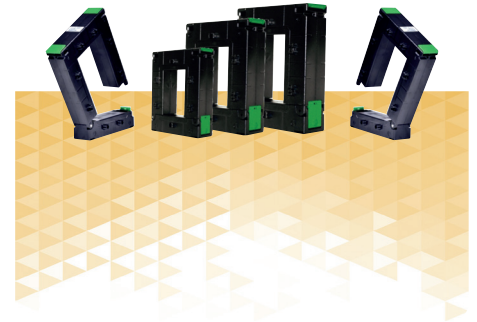

Features

- Compliant with EN 60044-1 / IEC 61869-1 Accuracy Class 0.5S
- Flame retardant grade enclosure (UL 94V-O)
- Operation free installation
- Test voltage 3kV 50Hz 1 min.
- System voltage 720V max.
- Ratio ratings from 100/5A to 4000/5A
- Available in 0.5, 1 and 3 accuracy class
- Insulation class: E
- UL approved
- High measuring accuracy
- The very high 0.5S accuracy class guarantees maximum metering, even with low loads.
- A 0.5S accuracy class means that the measurement has an error rate of 0.5% over a range of 20 to 120% of the nominal current (I_n) and at a specific accuracy above 1% of I_n .

OMEGA 10

Technical Information (Ref: IEC 61869-2)

Limits of Current Errors and Phase Displacements for Measuring Current Transformers (for Special Applications)															
Accuracy Class	± Percentage Current (ratio) Error at Percentage of Rated Current shown below					± Phase Displacements at Percentage of Rated Current									
						Minutes					Centiradians				
	1	5	20	100	120	1	5	20	100	120	1	5	20	100	120
0.25	0.75	0.35	0.20	0.20	0.20	30	15	10	10	10	0.90	0.45	0.30	0.30	0.30
0.55	1.50	0.75	0.50	0.50	0.50	90	45	30	30	30	2.70	1.35	0.90	0.90	0.90

OMEGA 108 (125mm wide x 40mm deep x (50mm x 80mm) I.D.)

Cat No.	Ratio	VA at CL 0.5S	Cat No.	Ratio	VA at CL 0.5S
XS02-315036S000000	400/5A	1.5VA	XS02-395086S000000	1000/5A	5VA
XS02-335056S000000	600/5A	2.5VA	XS02-405086S000000	1200/5A	5VA
XS02-375076S000000	800/5A	3.75VA	XS02-435096S000000	1600/5A	6.25VA

Dimensions

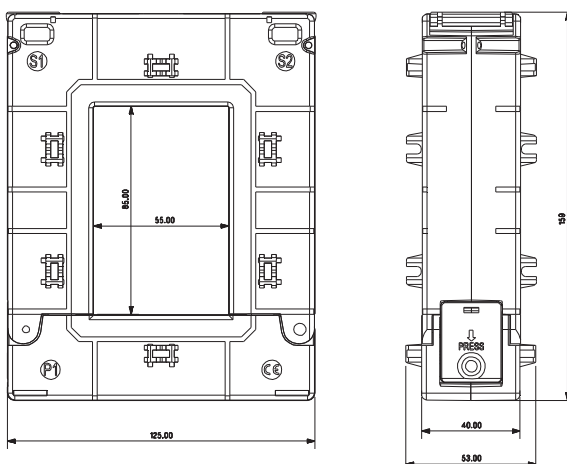

OMEGA 10B



OMEGA 10C

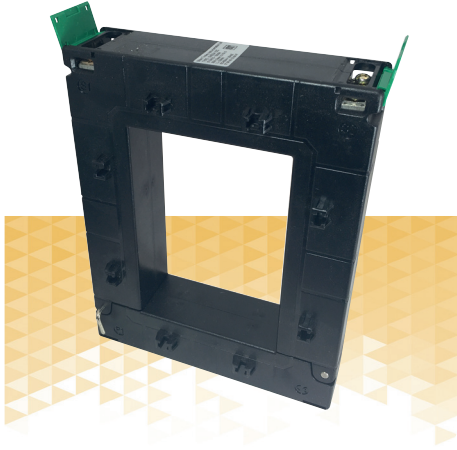

OMEGA 1 QC (155mm wide x 40mm deep x (120mm x 80mm) I.D.)

Cat No.	Ratio	VA at CL 0.5S
XS03-395086S000000	1000/5A	5VA
XS03-405086S000000	1200/5A	5VA
XS03-435106S000000	1600/5A	7.5VA

Cat No.	Ratio	VA at CL 0.5S
XS03-445106S000000	2000/5A	7.5VA
XS03-465106S000000	2500/5A	7.5VA
XS03-485106S000000	3000/5A	7.5VA

Dimensions

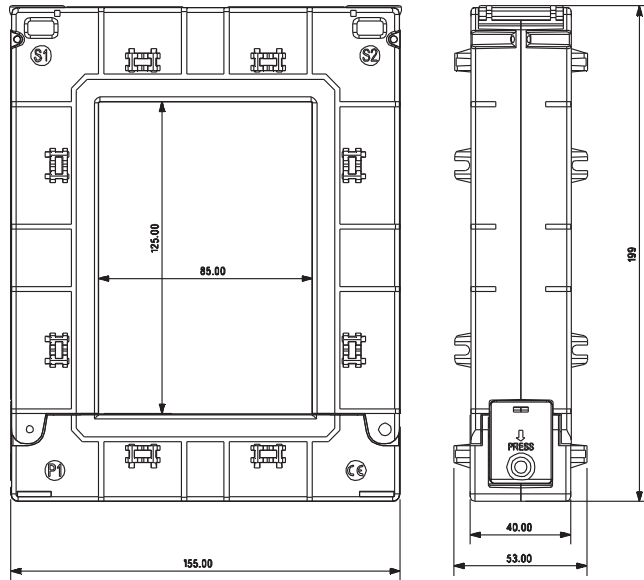

OMEGA 10D



OMEGA 1 OD (195mm wide x 64mm deep x (80mm x 160mm) I.D.)

Cat No.	Ratio	VA at CL 0.5S
XS04-445116S000000	2000/5A	10VA
XS04-485126S000000	3000/5A	12.5VA

Cat No.	Ratio	VA at CL 0.5S
XS04-515086S000000	4000/5A	5VA

Dimensions

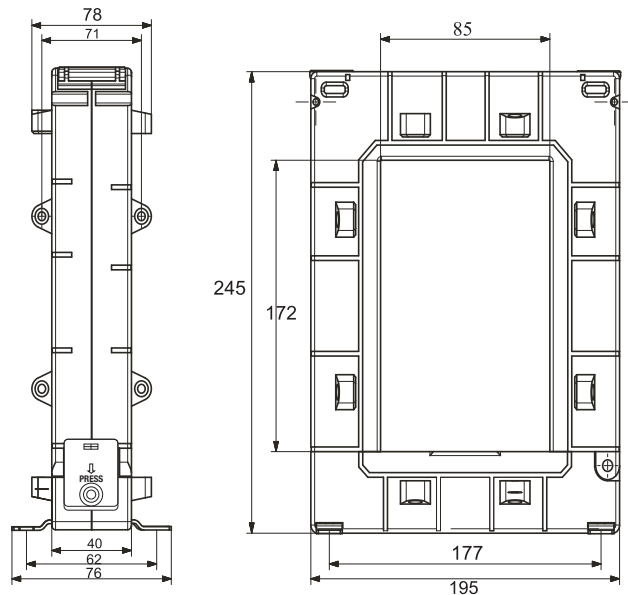

All dimensions are in mm

Contact

Sifam Tinsley Instrumentation

Address: 2105 Barrett Park Dr.
Unit 105, Kennesaw, GA 30144

Telephone: 800-879-6171

E-mail ID: info@sifamtinsley.com

Website: www.sifamtinsley.com
