



CST SERIES - CAM SWITCHES

- Complete range of cam switches for control, instrumentation and motor starting applications.
- Available for currents from 6 A to 200 A.
- Quick and easy installation.
- Compact size with many switching programs.
- Multi pole design.
- Long distance visibility.
- Touch-proof terminals with IP20 protection.

TYPES:

CST1 - CHANGEOVER

CST2 - MULTI-STEP

CST3 - ISOLATOR

CST4 - SELECTOR

APPLICATION EXAMPLES

Switching on the (emergency) power supply.

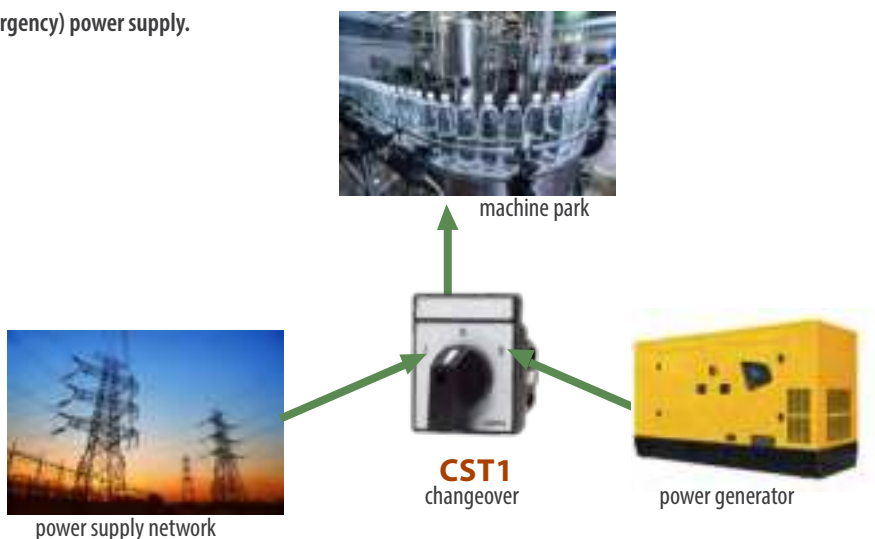

Measurement of phase and phase-to-phase voltage using only one voltmeter.

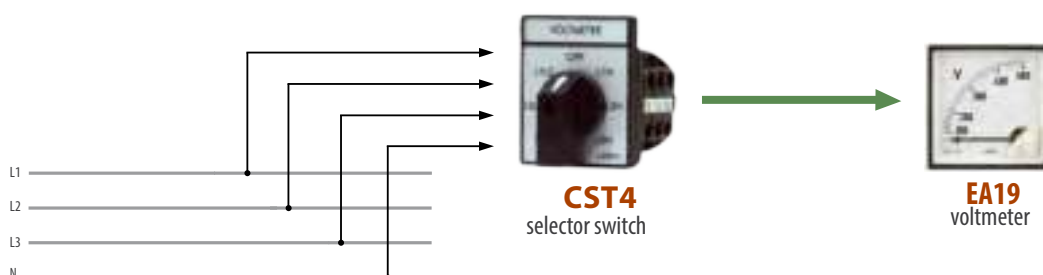

CST1/CST2/CST3/CST4

- CAM SWITCHES

EXTERNAL DIMENSIONS

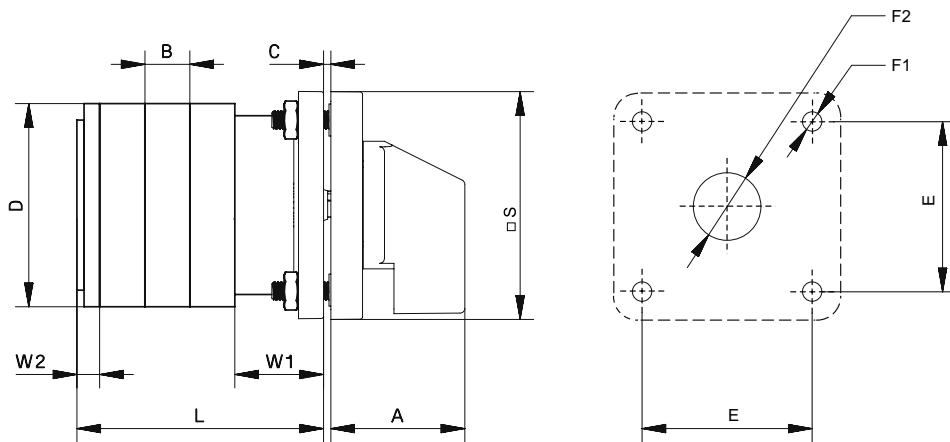

$$L = \text{No. of Stages of Prog} \times B + W1 + W2$$

Drilling plane

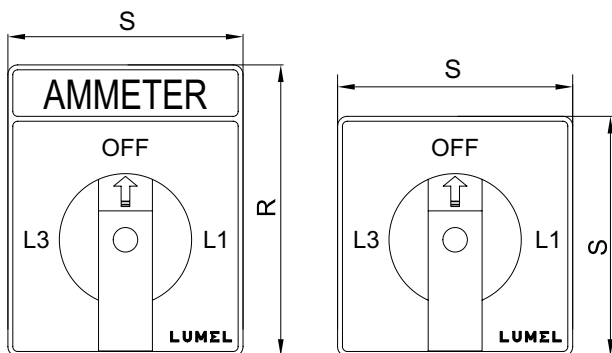

Type	A	B	C _(max)	D	E	F1	F2	R	S	W1	W2
6 A	29 mm	9.7 mm	4 mm	32 mm	36 mm	4 mm	8 mm	48 mm	48 mm	13 mm	7 mm
10 A	29 mm	9.5 mm	4 mm	43 mm	36 mm	4 mm	7 mm	60 mm	48 mm	19 mm	5 mm
16 A	29 mm	9.5 mm	4 mm	43 mm	36 mm	4 mm	7 mm	60 mm	48 mm	19 mm	5 mm
20 A	29 mm	9.5 mm	4 mm	43 mm	36 mm	4 mm	7 mm	60 mm	48 mm	19 mm	5 mm
25 A	34 mm	14.3 mm	4 mm	53 mm	48 mm	4 mm	12 mm	64 mm	64 mm	24 mm	6.2 mm
32 A	34 mm	14.3 mm	4 mm	53 mm	48 mm	4 mm	12 mm	64 mm	64 mm	24 mm	6.2 mm
40 A	34 mm	14.3 mm	4 mm	53 mm	48 mm	4 mm	12 mm	64 mm	64 mm	24 mm	6.2 mm
63 A	34 mm	14.3 mm	4 mm	53 mm	48 mm	4 mm	12 mm	64 mm	64 mm	24 mm	6.2 mm
100 A	49 mm	29 mm	4 mm	88 mm	68 mm	5.5 mm	18 mm	88 mm	88 mm	27 mm	7 mm
200 A	49 mm	29 mm	4 mm	88 mm	68 mm	5.5 mm	18 mm	88 mm	88 mm	27 mm	7 mm

INSTALLATION

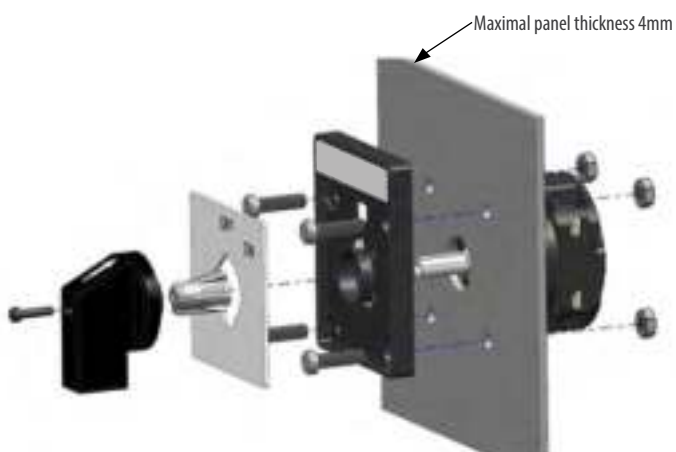

AC DUTY RATINGS

Class	Application
AC-1	Non-Inductive or slightly inductive loads ($\cos\phi \geq 0,95$); Resistance furnaces
AC-3	Squirrel-cage motors: starting switching off motors during running
AC-15	Control of AC electromagnetic loads
AC-21-A	Switching of resistive loads, including moderate overloads (frequent switching)
AC-23-A	Switching of motor loads or other highly inductive loads (frequent switching)

CST1/CST2/CST3/CST4 - CAM SWITCHES

TECHNICAL DATA

PARAMETERS		UNIT	6 A	10 A	16 A	20 A	25 A	32 A	40 A	63 A	100 A	200 A
Rated operational voltage (Ue)		V	440	440	690	690	690	690	690	690	690	690
Rated insulation voltage (Ui)		V	440	440	690	690	690	690	690	690	690	690
Rated uninterupted current (Ith)		A	8	12	20	25	25	32	40	63	100	200
Rated short time withstand current (Icw)		A	72	120	192*	240*	300	384	480	756	1200	2400
Rated impulse withstand voltage (Uimp)		kV	4	4	4	4	6	6	6	6	6	6
Rated Fuse short circuit current		kA	3	3	5	5	10	10	10	10	15	25
Fuse size (Type gG/ gM)		A	6	10	16	20	25	32	50	63	100	200
The power of the receiver in terms of use												
AC23A 3 phase	220-240V	kW	1.1	1.8	3	3.7	4.7	5.5	7.5	11	22	22
	380-440V	kW	1.8	3	5.5	7.5	7.5	11	15	18.5	37	37
	500V	kW	-	-	5.5	7.5	11	15	18.5	22	45	45
	660-690V	kW	-	-	5.5	7.5	11	15	18.5	22	45	45
AC23A 1 phase	110V	kW	0.25	0.37	0.55	0.75	1.5	2.2	2.2	3	-	-
	220-240V	kW	0.5	0.75	1.5	2.2	3	3.7	5.5	7.5	-	-
	380-440V	kW	0.75	1.1	2.2	3.7	5.5	7.5	7.5	11	-	-
AC3 3 phase	220-240V	kW	1.1	1.5	3	3	4.7	5.5	7.5	11	22	22
	380-440V	kW	1.8	2.2	5.5	5.5	7.5	11	15	18.5	37	37
	500V	kW	-	-	5.5	5.5	11	15	18.5	22	45	45
	600-690V	kW	-	-	5.5	5.5	11	15	18.5	22	45	45
AC3 1 phase	110V	kW	0.25	0.3	0.55	0.6	1.5	2.2	2.2	3	-	-
	220-240V	kW	0.5	0.55	1.5	2.2	3	3.7	5.5	7.5	-	-
	380-440V	kW	0.75	0.75	2.5	3	5.5	7.5	7.5	11	-	-
AC21A/AC1		A	6	10	16	20	25	32	40	63	100	200
AC15	220-240V	A	2	2.5	5	5	8	14	16	16	20	-
	380-440V	A	1	1.5	4	4	5	6	7	7	10	-
Terminal cross-section												
Single / Multiple	Min	mm ²	0.7	0.7	1.5	1.5	2.5	2.5	4	4	10	10
	Max	mm ²	1.5	1.5	4	4	4	6	10	16	35	70
Fine strand with sleeve	Min	mm ²	0.7	0.7	1	1	1.5	1.5	2.5	2.5	10	10
	Max	mm ²	1.5	1.5	2.5	2.5	4	4	6	16	35	50
Terminal screw		metric	M3	M3	M3	M3	M4	M4	M4	M4	M10	M10
Terminal tightening torque		Nm	0.8	0.8	0.8	0.8	1.2	1.2	1.2	1.2	2.5	2.5

* Rated short time withstand current (0.5s- current)

RATED OPERATING CONDITIONS

Frequency	50/60 Hz	
Operating temperature	-25°C...60°C	
Storage temperature	-40°C...80°C	
Installation category	III	
Altitude a.s.l.	2000 m	
Protection grade	IP50 from frontal side	IP20 from terminal side
Standards	IEC 60947-1, IEC 60947-3, IEC 60947-5	

SWITCH LIFE

Mechanical Life	100 000 operations at 300 cycles/hr	
Electrical Life	10 000 operations at 100% rated duty at 120 cycles/hr	
Contacts	double break	type AgNi
	double break	type AgCdO

CST4 SERIES

- SELECTOR SWITCHES

WIRING DIAGRAMS AND CODING

SELECTOR SWITCHES CST4

Ordering code CST4-69LXXXOF__00



Selector switch CST4-	69LXXXOF	-	-	00
Rated current:				
6 A	1			
10 A	B			
16 A	C			
20 A	J			
Front plate colour:				
silver background and black knob		A		
yellow background and red knob		Y		
Acceptance tests:				
without additional quality requirements			0	
with an extra quality inspection certificate			1	

ITEMS AVAILABLE FROM OUR STOCK:

CST4-C69LXXXOFA000

- Selector switch 16A, for ammeter, 5-way L123/N/OFF, rotation angle <360°, with OFF, rectangular knob, silver background, black knob

CST4-C69LXXXOFY000

- Selector switch 16A, for ammeter, 5-way L123/N/OFF, rotation angle <360°, with OFF, rectangular knob, yellow background, red knob

Description	6A	10A	16A
	Stage number		
5-way for the ammeter	4	4	4

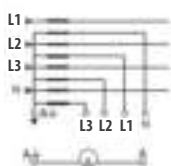
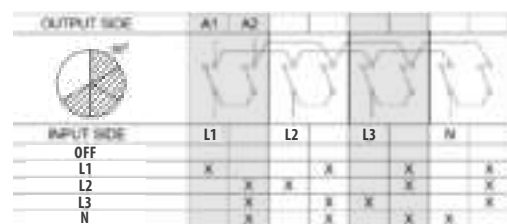

Ordering code CST4-97TXXXOF__00

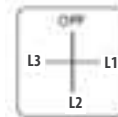

Selector switch CST4-	97TXXXOF	-	-	00
Rated current:				
6 A	1			
10 A	B			
16 A	C			
20 A	J			
Front plate colour:				
silver background and black knob		A		
yellow background and red knob		Y		
Acceptance tests:				
without additional quality requirements			0	
with an extra quality inspection certificate			1	

ITEMS AVAILABLE FROM OUR STOCK:

CST4-C97TXXXOFA000

- Selector switch 16A, for ammeter, 4-way L123/OFF, rotation angle 360°, with OFF, rectangular knob, silver background, black knob

CST4-C97TXXXOFY000

- Selector switch 16A, for ammeter, 4-way L123/OFF, rotation angle 360°, with OFF, rectangular knob, yellow background, red knob

Description	6A	10A	16A
	Stage number		
4-way for the ammeter	3	3	3

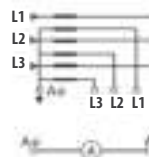
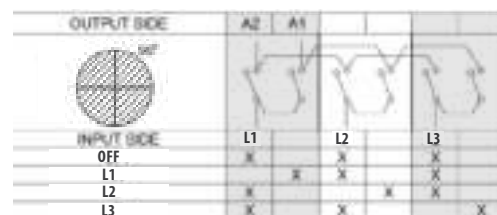

CST4 SERIES- SELECTOR SWITCHES

WIRING DIAGRAMS AND CODING

SELECTOR SWITCHES CST4

Ordering code CST4-4HLXXXOF__00

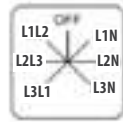

Selector switch CST4-	4HLXXXOF	-	-	00
Rated current:				
6 A	1			
10 A	B			
16 A	C			
20 A	J			
Front plate colour:				
silver background and black knob	A			
yellow background and red knob	Y			
Acceptance tests:				
without additional quality requirements			0	
with an extra quality inspection certificate			1	

ITEMS AVAILABLE FROM OUR STOCK:

CST4-C4HLXXXOFA000

- Selector switch 16A, do woltomierza, 7-way L-L/L-N/OFF, rotation angle <math><360^\circ</math>, with OFF, rectangular knob, silver background, black knob

CST4-C4HLXXXOFY000

- Selector switch 16A, do woltomierza, 7-way L-L/L-N/OFF, rotation angle <math><360^\circ</math>, with OFF, rectangular knob, yellow background, red knob

Description			
	6A	10A	16A
	Stage number		
Phase and phase-to-phase voltages	3	3	3

OUTPUT SIDE	V2	V1		
INPUT SIDE	L3	L2	L1	N
L3L1			X	
L2L2	X	X		
L1L2			X	X
OFF				
L1N			X	X
L2N		X		X
L3N	X			X

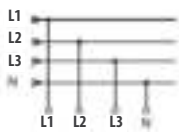

Ordering code CST4-9BTXXXOF__00

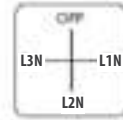

Selector switch CST4-	9BTXXXOF	-	-	00
Rated current:				
6 A	1			
10 A	B			
16 A	C			
20 A	J			
Front plate colour:				
silver background and black knob	A			
yellow background and red knob	Y			
Acceptance tests:				
without additional quality requirements			0	
with an extra quality inspection certificate			1	

Description			
	6A	10A	16A
	Stage number		
Phase voltages	3	3	3

OUTPUT SIDE	V1	V2		
INPUT SIDE	N	L1	N	L2
OFF				
L1L2	X	X		
L2L3			X	X
L3L1				X

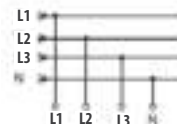

CST4 SERIES

- SELECTOR SWITCHES

WIRING DIAGRAMS AND CODING

SELECTOR SWITCHES CST4

Ordering code CST4-98TXXOF__00

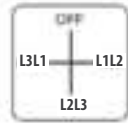

Selector switch CST4		98TXXOF			00
Rated current:					
6 A	1				
10 A	B				
16 A	C				
20 A	J				
Front plate colour:					
silver background and black knob		A			
yellow background and red knob		Y			
Acceptance tests:					
without additional quality requirements		0			
with an extra quality inspection certificate		1			

Description	6A	10A	16A
	Stage number		
Phase-to-phase voltages	3	3	3

STRONA WYJSCIOWA	V2	V1		
STRONA WEJSCIOWA	L1	L2	L3	
OFF				
L1L2	X		X	
L2L3		X		X
L3L1			X	X

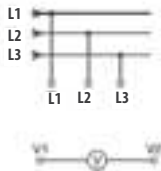

CODING OF CST4

Selector switch CST4					X	XX	O	F			00
Rated current:											
6 A	1										
10 A	B										
16 A	C										
20 A	J										
Meter type:											
ammeter L123/OFF/90°	97										
ammeter L123/N/OFF/60°	69										
voltmeter L-L/L-N/OFF/45°	4H										
voltmeter L-L/OFF/90°	98										
voltmeter L-N/OFF/90°	9B										
Rotation angle:											
360° *	T										
less than 360° **	L										
----- X											
----- XX											
----- O											
----- F											
Front plate colour:											
silver background and black knob		A									
yellow background and red knob		Y									
Acceptance tests:											
without additional quality requirements		0									
with an extra quality inspection certificate		1									
Version:											
standard		00									
custom-made***		XX									

* - only for rotation angle 90°

** - only for rotation angle 45° i 60°

*** - only after agreeing with the manufacturer

CST1/CST2/CST3/CST4 SERIES

- CAM SWITCHES

ACCESSORIES - ORDERING

Ordering code	Description	View	Cam switch type
20-042-06-00007	CAM SWITCH KNOB (Black)		CST1,CST2,CST3,CST4
20-042-06-00008	CAM SWITCH KNOB (Red)		CST1,CST2,CST3,CST4
20-042-06-00009	FRONT PLATE CAM SWITCH (Yellow)		CST1,CST2,CST3,CST4
20-042-06-00010	Yellow BLANK PAPER FOR MARKING PLATE		CST1,CST2,CST3,CST4
20-042-06-00011	Yellow BLANK PAPER FOR NAME PLATE		CST1,CST2,CST3,CST4
20-042-06-00012	BLANK NAME PLATE		CST1,CST2,CST3,CST4
20-042-06-00013	BLANK MARKING PLATE		CST1,CST2,CST3,CST4
20-042-06-00016	SCREWS AND NUTS		CST1,CST2,CST3,CST4