



# Technical Data Sheet

## *Alpha ML1410*

### *(Class 0.5S)*



**Alpha ML1410** is Multiload Monitor with 12 single phase load or 12 3-phase 3-wire symmetric load or 4 three phase load option. It measures important electrical parameters of multiple loads simultaneously in a single unit, eliminating the need and cost of multiple panel meters. It provides quick, easy and error free current connections with plug and play connectors. It measures real time electrical parameters like Active / Reactive / Apparent energy and power, current, THD, demand, max demand for each load. The instrument has 4 configurable relay outputs, which can be used for Limit / Pulse / Residual Current / 3Phase Load Health Monitoring / Tariff / RTC / Timer tripping or alarms. This instrument communicates with either MODBUS or Ethernet connection.

## Application

- Large Power Distribution System
- Data Center Metering
- Residual Current Monitoring
- 3 Phase Load Health Monitoring
- Sub Tenant Energy Consumption
- Individual Load Management
- Tariff Based Load Tripping

## Product Features

- **Multiple Circuit Monitoring**
  - Measures & monitors Instantaneous Current, Voltage, Power & Energy for multiple loads simultaneously.
  - Meter allows 4 Three Phase or 12 3-phase 3-wire symmetric load or 12 Single Phase or Hybrid Load connections with the help of 12 Current and 1 channel 3 phase voltage measurement.
- **Plug and Play Current transformer**
  - RJ 12 connector is available for External CT connection, which enables easy, fast and error free installation. 2 meter long cable is provided with the CT.
- **Direct remote access**
  - Remote configuration of the Instrument via MODBUS or Ethernet.
  - Remote access of measured parameters.
- **Relay Output (optional)**
  - Potential free, very fast acting relay contact configurable as:
    - **Pulse** output which can be used to drive an external counter for energy measurement.
    - **Limit** (alarm) switch.
    - **Timer** mode for switching ON & OFF for configurable number of times.
    - Switch for unhealthy Three Phase load.
    - Energy **Tariff** based tripping.
    - **RTC** based tripping and un-tripping for configurable days of the week.
    - **Residual Current (RCM)** based tripping
    - **Remote Relay Control** using MODBUS or ethernet
- **THD and Individual Harmonics Measurement**
  - The instrument measures per phase THD and individual harmonic up to 31st harmonics for each voltage & current.
- **RTC (Real Time Clock)**
  - Inbuilt real time clock for display of date and time, along with time stamping for data logging and Event recording.
- **Easy & Cost Effective Installations**
  - Multiple circuit Connections on Single board provide easy & economical installation process.
- **Big LCD display with Backlit**
  - LCD shows 4 measurement parameters along with 9 digit energy parameter at a glance. It also shows load graphics for individual phases of the load.
  - The four keys provided at the front help in easy navigation between the loads and the corresponding measurement parameter screens.
- **Residual Current Monitoring**
  - The residual current flowing through a path can be acquired by using the CT with specified specifications and connecting it to an RJ12 input of the instrument.
- **Prepaid Tariff based tripping**
  - This feature provides the luxury of tripping the load whose energy has crossed the required threshold of the configured tariff amount.
  - The user just needs to set the energy, top-up amount and the rate per unit (kilo) of energy.
- **Health Monitoring of Three Phase Load**
  - This feature is applicable only for Three Phase loads.
  - A Three Phase load (such as a Three Phase motor) can be monitored for phase failure, phase reversal, voltage & current unbalance, under frequency, under voltage, over voltage and over current.
  - Further, set a relay on this mode and trip the configured load for protection against such faults.
- **Onsite programmable**
  - Onsite Programmable System Configuration 3PH4W / 3PH3W / 1PH2W / 3P3W Symmetric / RCM / No Load for each channel.
  - Onsite Programmable CT Primary, PT Primary and PT Secondary.

## Product Features

- **Energy as per IEC 62053**
- Independent counter for Import Active energy (kWh), Export Active energy (kWh), Capacitive Reactive energy (kVARh), Inductive Reactive energy (kVARh) or Apparent energy (kVAh) measurement.
- Active Energy accuracy Class 0.5S as per IEC 62053-22
- **Compliance to International Safety standards**
- Compliance to International Safety standard IEC 61010-1- 2010.
- **EMC Compatibility**
- Compliance to International standard IEC 61326.
- **Data logging**
- Meter has inbuilt 8MB Flash for datalogging.
- **Event Logging**
- Previous 5 events of fixed parameters can be logged with Date and time.
- **Time based logging**
- User selectable parameters (1 to 120) can be logged at regular intervals (1 to 60 min) with Date and Time stamp in internal memory and can be accessed via Modbus or Ethernet or USB.
- If 1 Parameter for example energy is selected with logging interval of 15 minutes, log of maximum 5.5 years are available for user.
- If 120 Parameters are selected with logging interval of 60 minutes, log of maximum 197 days are available for user.
- **Load Profile logging**
- Logging of energy consumed and peak Demand (Power and Current) in a day and in a month for efficient tracking of load behaviors. Maximum 1 year daily and 14 years of monthly log is available for user.

## Technical Specifications

### Input Voltage

Nominal Input Voltage (AC RMS)	100 VLL to 600 VLL (57.7 VLN to 346.42 VLN) programmable on site
System PT primary values	100VLL to 1200kVLL programmable on site
Max continuous input voltage	120% of nominal value
Overload Withstand	2 x rated value for 1 second, repeated 10 times at 10 second intervals
Overload Indication	"-OL-" >121% of Nominal value
Nominal input voltage burden	< 0.3VA approx. per phase (at nominal 240V)

### Input Current

Nominal Input Current	100mA
System CT secondary Values	From 1A to 9999A
Max Continuous Input Current	120% of nominal value
Overload Withstand	5 x rated value for 1 second, repeated 5 times at 5 minute intervals
Overload Indication	"-OL-" >121% of Nominal value
Nominal input current burden	< 0.05VA approx. per phase

### Auxiliary Supply

Auxiliary supply range	100-550V AC/DC
Aux Supply frequency	45 to 65 Hz range
Auxiliary Supply Burden (at 230V AC DC)	
With Addon card	< 8 VA approx ( 2 Relay)
	< 10 VA approx ( 4 Relay )
With Ethernet card	< 9 VA approx.

### Operating Measuring Ranges

Current (Energy Measurement)	1...120% of nominal value
Starting current	As per Standard IEC62053-22 (Class 0.5S)
Voltage	20... 120% of nominal value
Power Factor	0.5 Lag ... 1... 0.8 Lead
Frequency	45Hz to 66Hz

### Reference Conditions for Accuracy

Reference temperature	23°C +/- 2°C
Input Waveform	Sinusoidal (distortion factor 0.005)
Input frequency	50/60 Hz ± 2%
Auxiliary supply	230V AC/DC ± 1%
Auxiliary supply frequency	50/60 Hz ± 1%
Total Harmonic distortion	50% up to 15th Harmonics 10% up to 31st Harmonics (Current range 20%...100% of nominal value)
Voltage range	50%...100% of nominal value

## Technical Specifications

<b>Accuracy</b>	
Active Energy	Class 0.5S as per IEC 62053 - 22
Apparent Energy	Class 1
Reactive Energy	Class 2 as per IEC 62053 - 23
Active Power	±0.5% of nominal value
Re-Active Power	±1.0% of nominal value
Apparent Power	±0.5% of nominal value
Power Factor/Phase Angle	±3°
Voltage	±0.5% of nominal value
Current	±0.5% of nominal value
Current (RCM)	±5.0% of reading
Frequency	± 0.2% of mid frequency
THD (Voltage/Current)	± 3.0%
<b>Display update rate</b>	
Response time to step input	1 sec approx
<b>Applicable Standards</b>	
Electromagnetic Compatibility	EC 61326 - 1, Table 2
Immunity	IEC 61000-4-2, -3, -4, -5, -6, -8, -11
Emission	CISPR 11
Safety	IEC 61010-1-2010
IP for water & dust	IEC 60529
Pollution degree	2
Installation category	III
<b>Isolation</b>	
Protective Class	2
High voltage test	
1. Input + Aux vs Surface	4kV RMS, 50Hz, 1min
2. Input vs Remaining Circuit	3.3kV RMS, 50Hz, 1min
<b>Environmental</b>	
Operating temperature	-20 to + 70°C
Storage temperature	-25 to + 75°C
Relative humidity	0... 95%RH (non condensing)
Warm up time	Minimum 3 minute
Shock (As per IEC60068-2-27)	Half sine wave, Peak acceleration 30gn (300 m/s <sup>2</sup> ), duration 18ms.
Vibration	10... 150...10 Hz, 0.15mm amplitude
Number of Sweep cycles	10 per axis
Enclosure	IP 20 (Terminal side) and IP54(Front Side)

## Technical Specifications

### Interfaces

Impulse Led	For Energy testing
Relay (Optional)	240 VAC, 5 A AC 30VDC, 5A DC
Modbus (Optional)	RS485, max.1200m Baud rate : 4.8k,9.6k,19.2k,38.4k, 57.6kbps
Eathernet (Optional)	Ethernet access on Modbus TCP/IP Protocol

### Weight

Weight	320 grams Approx
--------	------------------

## Parameter Measurement and Display (availability on display & modbus)

Sr No	Load Parameters	3Phase 4Wire	3Phase 3Wire	1P2W/3P3WSy
1	System Import Active Energy <sup>1</sup>	✓	✓	✗
2	System Export Active Energy <sup>1</sup>	✓	✓	✗
3	System Capacitive Reactive Energy <sup>1</sup>	✓	✓	✗
4	System Inductive Reactive Energy <sup>1</sup>	✓	✓	✗
5	System Apparent Energy <sup>1</sup>	✓	✓	✗
6	Channel Import Active Energy <sup>1</sup>	✓	✗	✓
7	Channel Export Active Energy <sup>1</sup>	✓	✗	✓
8	Channel Capacitive Reactive Energy <sup>1</sup>	✓	✗	✓
9	Channel Inductive Reactive Energy <sup>1</sup>	✓	✗	✓
10	Channel Apparent Energy <sup>1</sup>	✓	✗	✓
11	System Active Power (kW)	✓	✓	✗
12	System Reactive Power (kVAr)	✓	✓	✗
13	System Apparent Power (kVA)	✓	✓	✗
14	Channel Active Power (kW)	✓	✗	✓
15	Channel Reactive Power (kVAr)	✓	✗	✓
16	Channel Apparent Power (kVA)	✓	✗	✓
17	System Power Factor	✓	✓	✗
18	Channel Power Factor	✓	✗	✓
19	System Phase Angle	✓	✓	✗
20	Channel Phase Angle	✓	✗	✓
21	System Import kW Demand	✓	✓	✗
22	System Export kW Demand	✓	✓	✗
23	System Capacitive kVAr Demand	✓	✓	✗
24	System Inductive kVAr Demand	✓	✓	✗
25	System kVA Demand	✓	✓	✗
26	System Current Demand	✓	✓	✗
27	Channel Import kW Demand	✓	✗	✓
28	Channel Export kW Demand	✓	✗	✓
29	Channel Capacitive kVAr Demand	✓	✗	✓
30	Channel Inductive kVAr Demand	✓	✗	✓
31	Channel kVA Demand	✓	✗	✓
32	Channel Current Demand	✓	✗	✓
33	System Max Import kW Demand	✓	✓	✗
34	System Max Export kW Demand	✓	✓	✗
35	System Max Capacitive kVAr Demand	✓	✓	✗
36	System Max Inductive kVAr Demand	✓	✓	✗
37	System Max kVA Demand	✓	✓	✗
38	System Max Current Demand	✓	✓	✗
39	Channel Max Import kW Demand	✓	✗	✓
40	Channel Max Export kW Demand	✓	✗	✓
41	Channel Max Capacitive kVAr Demand	✓	✗	✓
42	Channel Max Inductive kVAr Demand	✓	✗	✓
43	Channel Max kVA Demand	✓	✗	✓
44	Channel Max Current Demand	✓	✗	✓
45	System Run Hour	✓	✓	✗
46	Channel Run Hour	✓	✗	✓
47	On Hour	✓	✓	✓

## Parameter Measurement and Display (availability on display & modbus)

Sr No	Load Parameters	3Phase 4Wire	3Phase 3Wire	1P2W/3P3WSy
48	Number of Interruptions	✓	✓	✓
49	System Current	✓	✓	✗
50	Channel Currents	✓	✓	✓
51	System Current THD	✓	✓	✗
52	Channel Current THD	✓	✓	✓
53	Current Channel Individual Harmonics (Up to 31st)	✓	✓	✓
54	System Neutral Current	✓	✗	✗
55	Frequency	✓	✗	✓
56	RPM	✓	✓	✓
57	Phase Sequence Indication	✓	✓	✗
58	Current Reversal Indication	✓	✓	✓
59	Phase (Current & Voltage) Absent Indication	✓	✗	✗

**Note: 1.** Energy on display is auto ranging & unit for Energy parameters on modbus are dependent on CT PT ratio or unit selected by user.

**Note: 2.** Parameters Applicable for 1Phase 2 Wire are applicable for 1Phase 2Wire Line to Line mode as well.

## Parameter Measurement and Display (availability on display & modbus)

Sr No	Voltage Parameters	3P 4W	3P 3W	1P2W	3P3WSy
60	System Voltage L-N <sup>2</sup>	✓	✗	✗	✗
61	System Voltage L-L <sup>2</sup>	✗	✓	✗	✗
62	Voltage L1 <sup>2</sup>	✓	✗	If Related	✗
63	Voltage L2 <sup>2</sup>	✓	✗	If Related	✗
64	Voltage L3 <sup>2</sup>	✓	✗	If Related	✗
65	Voltage L12 <sup>2</sup>	✓	✓	✗	✓
66	Voltage L23 <sup>2</sup>	✓	✓	✗	✓
67	Voltage L31 <sup>2</sup>	✓	✓	✗	✓
68	System Voltage L-N THD <sup>2</sup>	✓	✓	✗	✗
69	System Voltage L-L THD <sup>2</sup>	✓	✓	✗	✗
70	Voltage L1 THD <sup>2</sup>	✓	✗	If Related	✗
71	Voltage L2 THD <sup>2</sup>	✓	✗	If Related	✗
72	Voltage L3 THD <sup>2</sup>	✓	✗	If Related	✗
73	Voltage L12 THD	✗	✓	✗	✓
74	Voltage L23 THD	✗	✓	✗	✓
75	Voltage L31 THD <sup>2</sup>	✗	✓	✗	✓
76	Individual Harmonics of VL1(Up to 31st Harmonics) <sup>2</sup>	✓	✗	If Related	✗
77	Individual Harmonics of VL2 (Up to 31st Harmonics) <sup>2</sup>	✓	✗	If Related	✗
78	Individual Harmonics of VL3 (Up to 31st Harmonics) <sup>2</sup>	✓	✗	If Related	✗
79	Individual Harmonics of VL12(Up to 31st Harmonics) <sup>2</sup>	✗	✓	✗	✓
80	Individual Harmonics of VL23 (Up to 31st Harmonics) <sup>2</sup>	✗	✓	✗	✓
81	Individual Harmonics of VL31 (Up to 31st Harmonics) <sup>2</sup>	✗	✓	✗	✓

**Note: 2.** All the listed Voltage Parameters are available on modbus but only those which are relevant to the load are shown on display screen.  
For 1P2W load, only that phase voltage from which the load current is acquired, i.e., the Related voltage, is shown on display.

**Total / Overall Parameters (availability on display & modbus):**

Sr No	Load Parameters	Availability
82	Total System Voltage LN avg	✓
83	Total System Voltage LL avg	✓
84	Total System Current sum	✓
85	Total System Active Power sum	✓
86	Total System Reactive Power sum	✓
87	Total System Apparent Power sum	✓
88	Total System PF avg	✓
89	Total System PA avg	✓
90	Total System Wh Import sum	✓
91	Total System Wh Export sum	✓
92	Total System VARh Capacitive sum	✓
93	Total System VARh Inductive sum	✓
94	Total System VAh sum	✓
95	Total System Wh Import overflow count	✓
96	Total System Wh Export overflow count	✓
97	Total System VARh Capacitive overflow count	✓
98	Total System VARh Inductive overflow count	✓
99	Total System VAh overflow count	✓
100	Total System kW Import Demand sum	✓
101	Total System kW Export Demand sum	✓
102	Total System kVAr Capacitive Demand sum	✓
103	Total System kVAr Inductive Demand sum	✓
104	Total System kVA Demand sum	✓
105	Total System A Demand sum	✓
106	Total System kW Import Max Demand	✓
107	Total System kW Export Max Demand	✓
108	Total System kVAr Capacitive Max Demand	✓
109	Total System kVAr Inductive Max Demand	✓
110	Total System kVA Max Demand	✓
111	Total System Current Max Demand	✓

# Electrical Connections

All 3Phase Load Connections with 3Phase RJ12 CT :

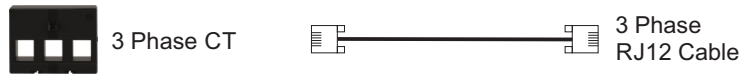
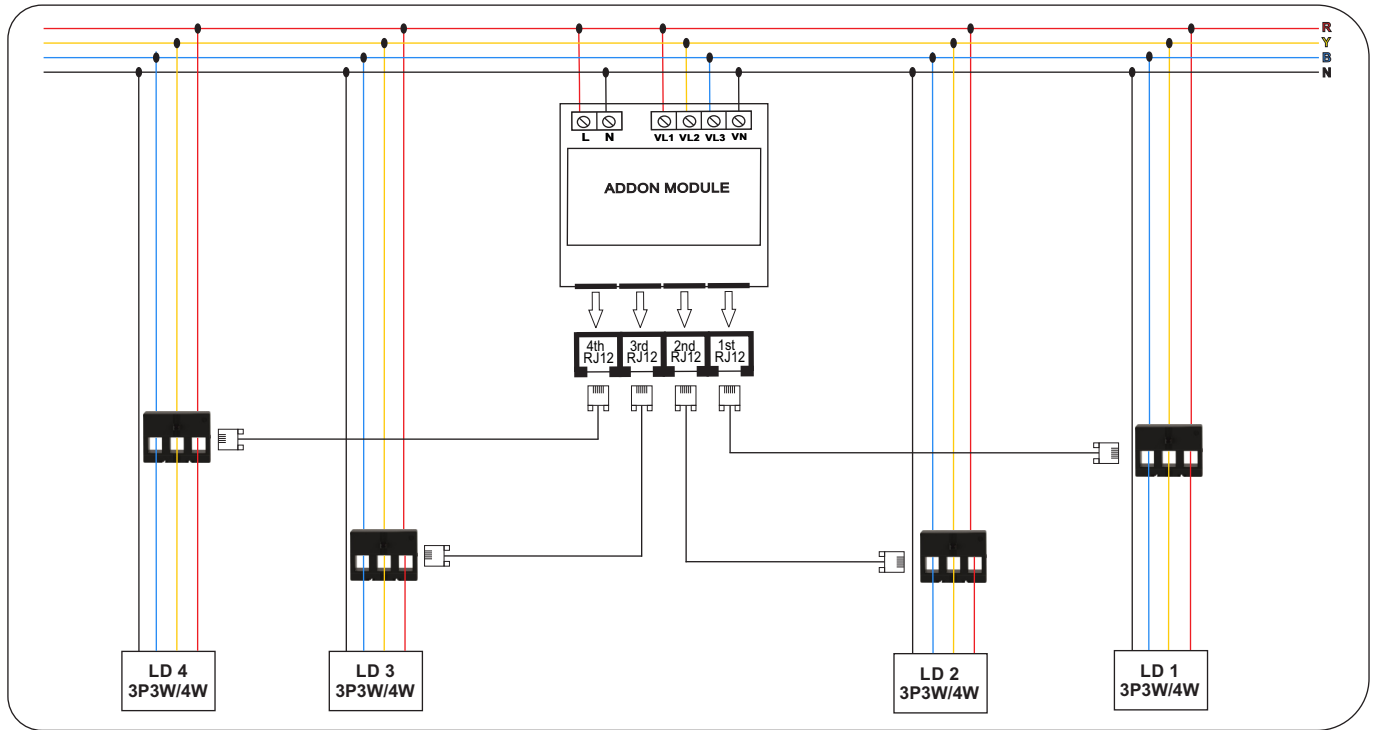

All 3Phase Load Connections With 1Phase 5A/1A CT :

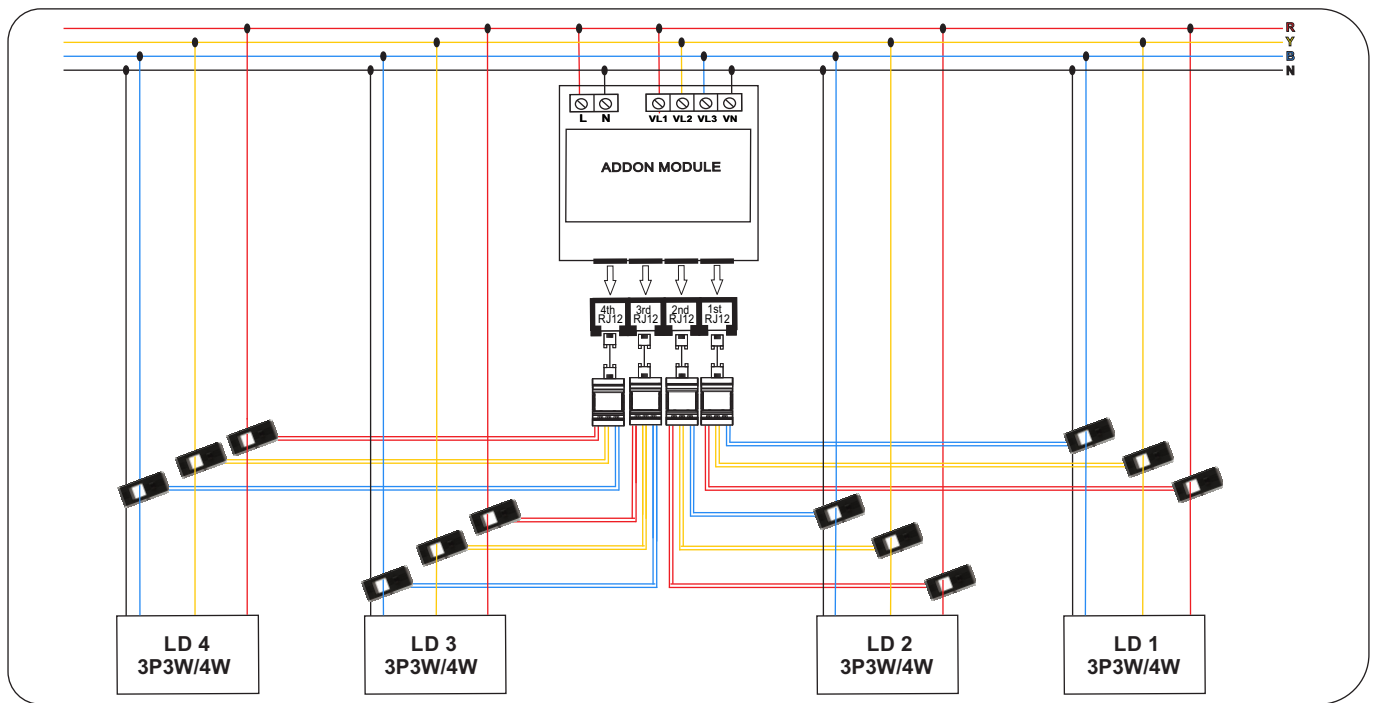

\*Note : User can use 3 phase 5A/1A CT instead of 3x 1 phase 5A/1A CT.

# Electrical Connections

All 1Phase Load Connections With 1Phase 5A/1A CT :

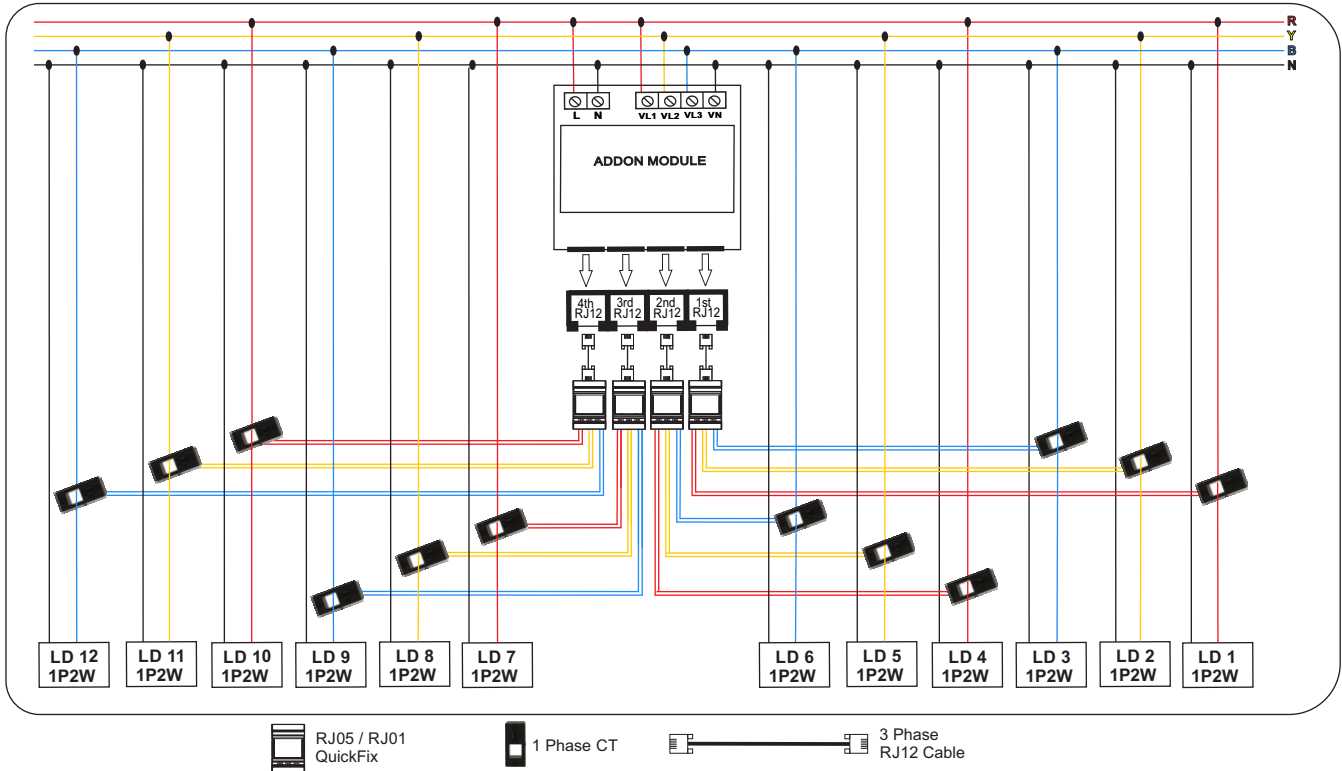

All 1Phase 2 Wire Load Connections With 1Phase RJ12 CT :

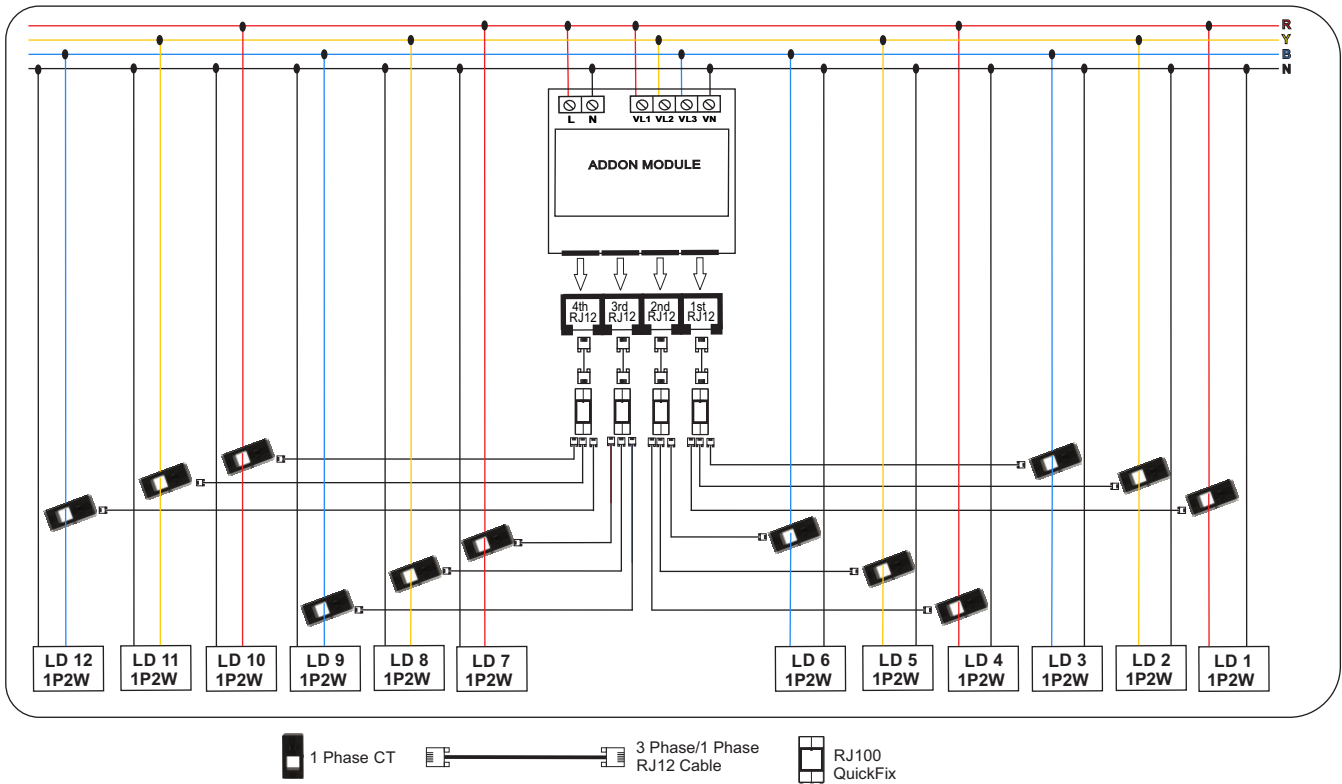

# Electrical Connections

All 3Phase Load Plus RCM Connections :

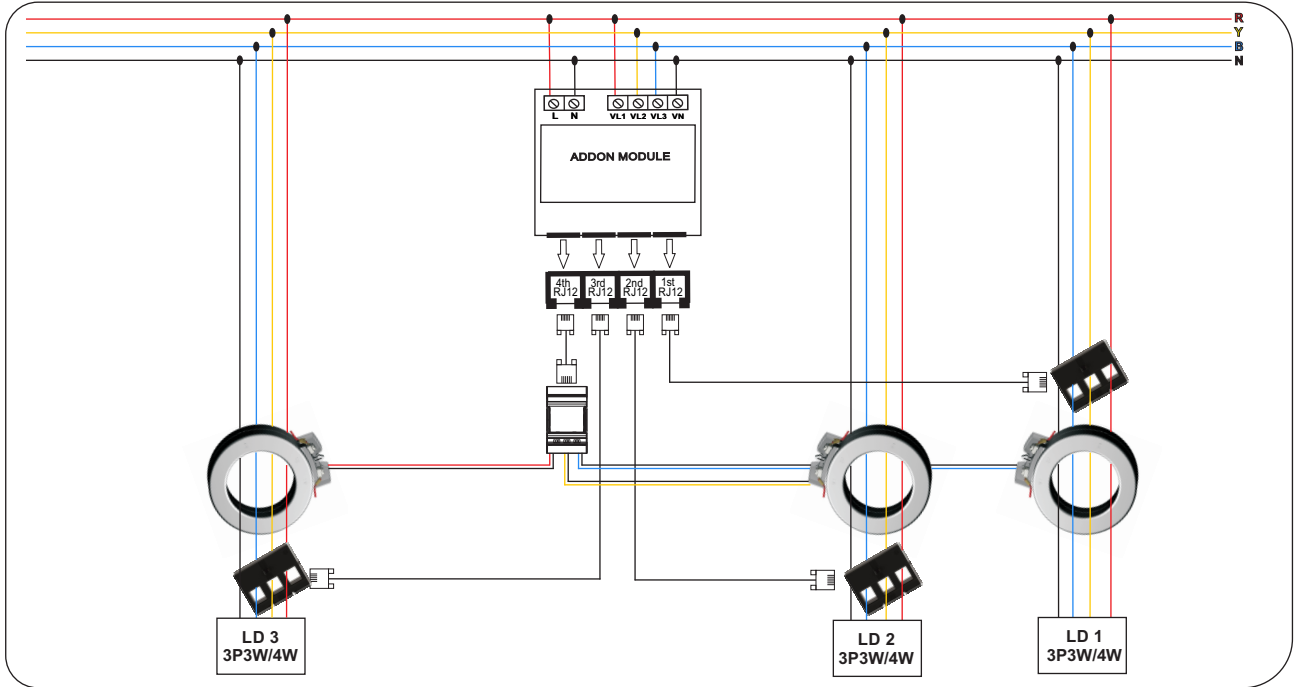

-  3 Phase CT
-  RC30 QuickFix
-  CBCT 30mA to 30A
-  3 Ph RJ12 Cable

\*Note : User can use 3 phase 5A/1A CT with "QuickFix 5A/1A to RJ12 Converter" for above application. Many combinations are possible in above application.

All 1Phase 5A/1A CT Plus RCM Connections :

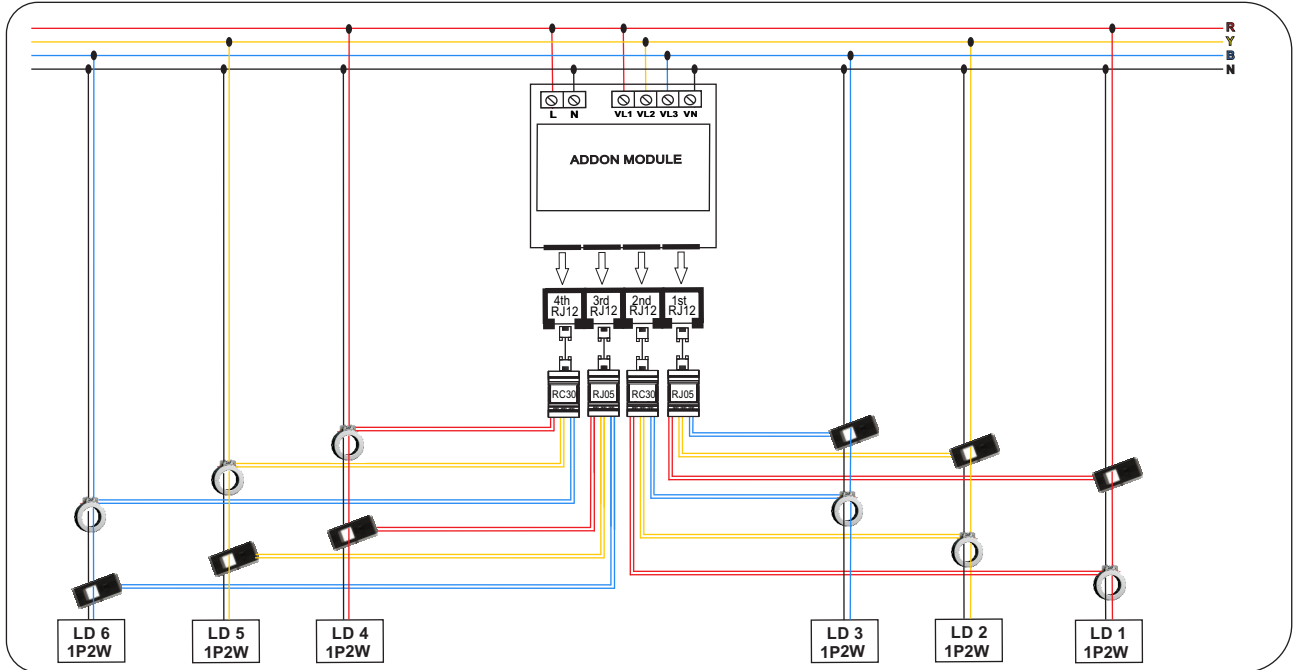

-  RC30 QuickFix
-  RJ05 / RJ01 QuickFix
-  CBCT 30mA to 30A
-  3 Phase RJ12 Cable

\*Note : User can use 1 phase RJ12 CT with "QuickFix 3x 1Phase RJ12 Converter" for above application. Many combinations are possible in above application.

# Electrical Connections

Hybrid Load Connections :

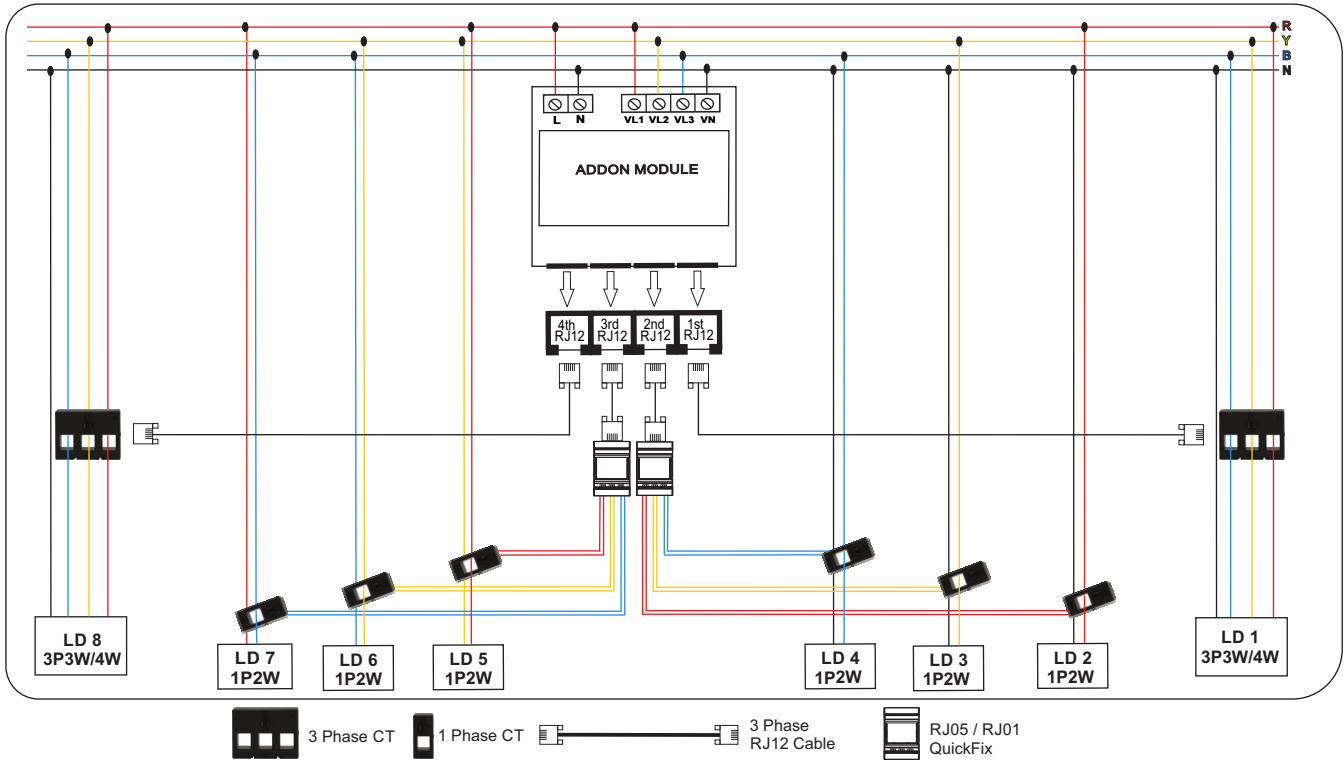

\*Note : Many combinations of 1 Phase 3 Phase load along with RCM are possible in above hybrid load connection.

All 3Phase 3 Wire Symetric Load Connections With 1Phase RJ12 CT :

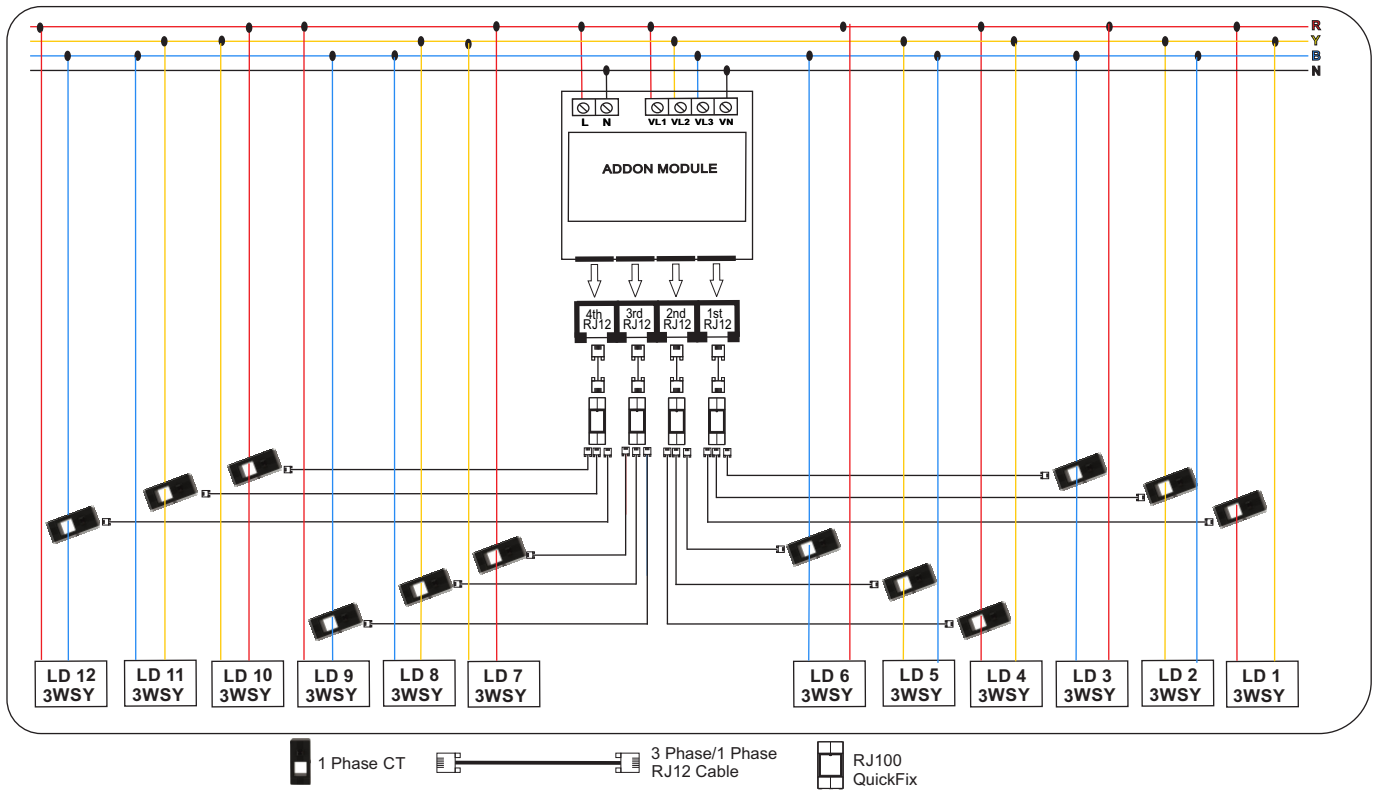

## Dimensions

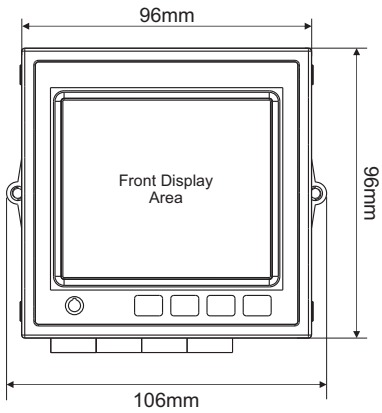

Front View

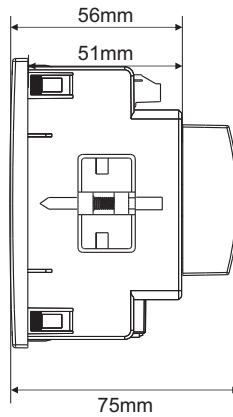

Side View

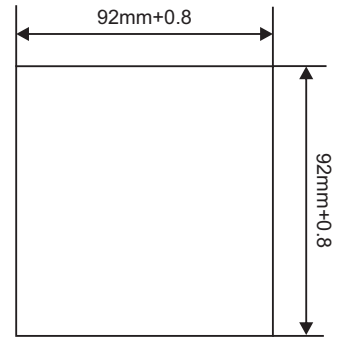

Panel Cutout

## Installation

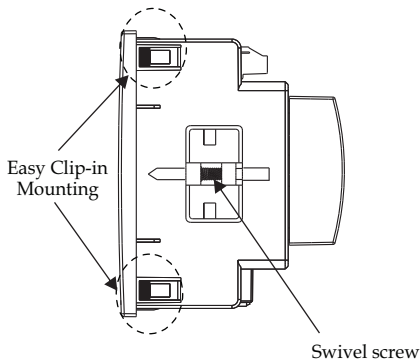

Electrical Connection (Backview)

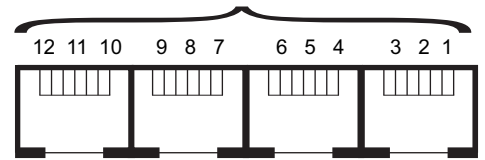
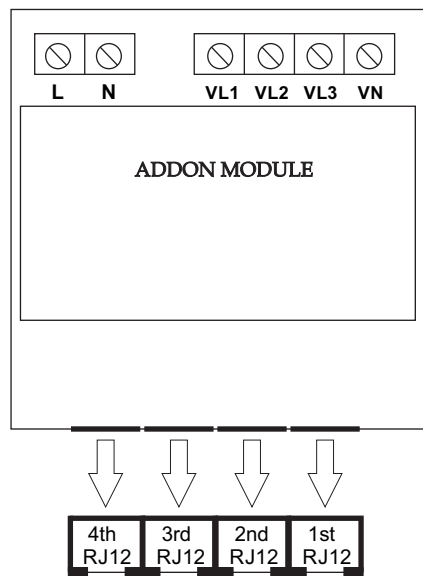

12 CHANNELS FOR CURRENT INPUT

Note : Use a single RJ12 input for "1 Three Phase load" or "3 Single Phase loads" or 3P3W-Symmetric load.

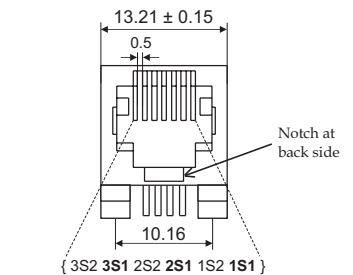

Meter Side RJ 12 Connection

## Current Transformers with RJ12 Output :



Omega 3PH RJ12



Omega Nano 3PH CT RJ12



Omega 1PH RJ12

## Ordering Information

Product Code	MLM1-	1	3	01	01	X	H	5	00ST
Model	Alpha ML1410								
System Type	3 Ph 3W/4W								
Input Voltage	100-600VLL								
Input Current	RJ12-100mA								
Output Option	Rs485 - 2 Relay					A			
	RS485 - 2 Relay - USB - Datalogging					C			
	RS485 - 4 Relay - USB - Datalogging					E			
	Ethernet - Datalogging					G			
Aux Voltage	100-550AC/DC								
Accuracy Class	Class 0.5S								

## Order Code Example

**MLM1-130101CH500ST** - Alpha ML1410 (Class 0.5) with input voltage 100-600 VLL, RJ12 (100 mA) current input, auxiliary voltage 100-550 V AC/DC, MODBUS (RS485) communication, 2 relays, USB, and datalogging.



**Sifam Tinsley Instrumentation Inc.**  
2105, Barrett Park Dr. Unit 105.  
Kennesaw, GA 30144, USA  
**E-mail Id :** [psk@sifamtinsley.com](mailto:psk@sifamtinsley.com)  
[info@sifamtinsley.com](mailto:info@sifamtinsley.com)  
**Web :** [www.sifamtinsley.com](http://www.sifamtinsley.com)  
**Contact No. :** +1 404 736 4903

**Sifam Tinsley Instrumentation Ltd**  
Unit 1 Warner Drive,  
Springwood Industrial Estate  
Braintree, Essex, UK, CM72YW  
**E-mail:** [sales@sifamtinsley.com](mailto:sales@sifamtinsley.com)  
**Web:** [www.sifamtinsley.com/uk](http://www.sifamtinsley.com/uk)  
**Contact:** +44(0)1803615139