



Technical Data Sheet

Alpha CM12

Compact VAF Meter



Alpha CM12 Compact VAF Meter measures important electrical parameters in 3 Phase 4 Wire, 3 Phase 3 Wire, 1 Phase Network & replaces the multiple analog panel meters.

Special Features

- True RMS measurement
- Voltage, Current, THD parameters
- 2 Line 4 digits ultra bright LED display
- Current input through RJ12 connector for fast, easy and error free connection
- User selectable 3PH 3wire / 3PH 4wire / Single phase network
- On site programmable CT primary, PT primary, PT secondary
- Optional RS485 (MODBUS) for remote settings and monitoring
- Optional Relay for limit/timer purpose can be used in system for automation / control
- Fast & Easy Installation on panel with self clicking

Application

- Motor Pump Panels
- Battery Charging Panels
- LV panels
- Test Bench Kits & Many More to Explore

Product Features

- **Display parameters**
 - Voltage VLN, VLL, Line current, Frequency, RPM, System Average Voltage, System Average Current, System Min-Max Voltage and Current, THD for phase and system Voltage and Current
- **True RMS measurement**
 - The instrument measures distorted waveform up to 15th Harmonic.
- **2 line 4 digits LED display**
 - 2 Line 4 digits seven segment LED display for simultaneous reading of voltage and current.
- **Storage of system parameters**
 - The instrument stores minimum and maximum values for system voltage, system current.
- **Front panel keys**
 - Using three key, it is possible to go to desired parameter on screen instantly. Three keys are also useful for easy setup navigation and changing setup parameter.
- **Display Autoscroll**
 - Display auto scroll enables user to see all parameters without key operation.
 - On site selection of auto/manual scrolling.
- **On site programmable PT parameters**
 - Potential Transformer (PT) primary and secondary is programmable on site through front panel keys and MODBUS.
 - PT Primary value ranging from 100VLL to 7999 kVLL.
 - PT Secondary value ranging from 100VLL to 500VLL.
- **User selectable system network**
 - User can program on site the network connection as 3 Phase 4 Wire, 3 Phase 3 Wire, 1 Phase 2 Wire.
 - User selectable low current suppression upto 30 mA.
- **Enclosure Protection for dust and water**
 - Conforms to IP 54 (for front face) & IP 20 (for back) & as per IEC60529.
- **Communication (Optional)**
 - Optional Isolated multi baud rate RS485 (MODBUS) output for remote viewing, configuration and external logging.
- **Relay output**
 - Optional potential free NO contact limit relay output and timer function.
- **Limit function parameter setting**
 - - Energizing and de-energizing relay configuration.
 - - Parameter selection.
 - - Trip level percentage.
 - - Hysteresis percentage.
 - - On delay.
 - - Off delay.
- **Timer function parameters setting**
 - - On delay.
 - - Off delay.
 - - Number of cycles.
- **User selectable CT Primary**
 - Primary of external Current Transformer (CT) is programmable
 - on site through front panel keys.
 - CT Primary value ranging from 1A to 9999 A.
- **Plug and Play RJ12 input connection**
 - RJ12 connector is available for external CT connection for fast, easy and error free installation. The current rating is 120 mA maximum.
- **Auxiliary supply**
 - Higher Auxiliary power supply with voltage range 60V-280VAC / DC.
 - Lower Auxiliary power supply with voltage range 20-60 VAC / DC.
- **Back depth**
 - The instrument has back depth of 64.3 mm and 76.4 behind the panel without and with RS485 respectively.
- **EMC Compatibility**
 - Compliance to IEC61326

Technical Specifications

Operating Measuring Ranges

Voltage Range	10VLL 600VLL AC RMS
Current Range	5mA120mA AC RMS
Frequency	45...65 Hz

Input Voltage

Nominal input voltage (Vn)	100-500 VLL (57.7 - 288.7 VLN)
Max continuous input voltage	120% of Nominal value
Nominal input voltage burden	0.3 VA approx. per phase at Nominal 240 VLN
System PT secondary values	100VLL to 500 VLL programmable on site
System PT secondary values	100VLL to 7999 kVLL programmable on site

Input Current

Nominal input current (In)	100mA
System CT primary values	From 1A to 9999A
Max continuous input current	120% of nominal value
Nominal input current burden	0.1 VA approx. per phase at In

Auxiliary Supply

Higher AC-DC External Aux.	60-280V AC-DC (230V AC/DC Nominal)
Lower AC-DC External Aux.	20-60V AC/DC (24V AC/48V DC Nominal)
Frequency range	45 to 65 Hz
VA burden	< 5 VA Approx.

Overload Withstand

Voltage	2x Nominal value for 1 second, repeated 10 times at 10 second intervals
---------	---

Reference Conditions for Accuracy

Reference Conditions (As per IEC 62053 - 21)	23°C +/- 2°C
Input waveform	Sinusoidal (distortion factor 0.005)
Input frequency	50 or 60 Hz ±2%
Auxiliary supply voltage	Nominal Value ±1%
Auxiliary supply frequency	Nominal Value ±1%
Total Harmonics distortion	THD-V < 30 % at Vn upto 15th harmonics(Individual 15th harmonics < 30 %) THD-I < 50 % at In upto 15th harmonics(Individual 15th harmonics < 30 %)

Display update rate

Response time to step input	Less than 1 second
-----------------------------	--------------------

Accuracy

Voltage	± 0.5 % of Nominal Voltage (20... 100% of Nominal value)
Current	± 0.5 % of Nominal Current (10... 100% of Nominal value)
Frequency	± 0.2 % of mid frequency
%THD Accuracy	± 4%

Technical Specifications

Influence of Variations	
Temperature coefficient (for nominal value range of use -20°C to 60°C)	0.025 % /°C for Voltage and Frequency 0.05 % /°C for Current
Applicable Standards	
EMC	IEC 61326 - 1 : 2012, (Table 2)
Safety	IEC 61010-1-2010 , Permanently connected use
IP for water & dust	IEC 60529
Interfaces: (optional)	
MODBUS	RS485 Baud rate : 4.8, 9.6,19.2, 38.4, 57.6 kbps
Relay	250 VAC, 5 A AC, 30VDC, 5A DC
Environmental	
Operating temperature	-20°C to +60°C
Storage temperature	-30°C to +70°C
Relative humidity	0... 90%(non condensing)
Warm up time	Minimum 3 minute
Shock	Half sine wave, Peak acceleration 30gn (300 m/s ²), duration 18ms 3 axis- 6 Shocks in each axis
Vibration	10... 55Hz, 0.15mm amplitude
Altitude	2000 m max
Enclosure	
Front	IP 54
Back	IP 20
Mechanical	
Housing dimensions	49 x 49 x 74.6 mm ³
Panel cut-out	45 x 45 mm ²
Back depth with/without MODBUS	76.4 mm, 64.3 mm
Packed/Unpacked Weight	140 gm, 112 gm
Clamp Screw Size	M3
Cable size for Voltage and Aux	2.5 mm ²
Cable size for Relay and Modbus	2.5 mm ²
Torque to be applied	0.3 N-m to 0.5 N-m
Safety	
Pollution degree	2
Installation category	III
High Voltage Test	3.3 kV AC, 50Hz for 1 minute between aux. and measuring inputs 2.2 kV AC, 50Hz for 1 minute between aux. and MODBUS and relay

Parameter Measurement and Display

Sr No	Displayed Parameters	3Phase 4Wire	3Phase 3Wire	1Phase 2Wire
1	System Voltage	✓	✓	✓
2	System Current	✓	✓	✓
3	Volts L1-N	✓	✗	✓
4	Volts L2-N	✓	✗	✗
5	Volts L3-N	✓	✗	✗
6	Volts L1-2	✓	✓	✗
7	Volts L2-3	✓	✓	✗
8	Volts L3-1	✓	✓	✗
9	Current L1	✓	✓	✓
10	Current L2	✓	✓	✗
11	Current L3	✓	✓	✗
12	Max (System Voltage / System Current)	✓	✓	✓
13	Min (System Voltage / System Current)	✓	✓	✓
14	System frequency and RPM	✓	✓	✓
15	Per Phase Voltage and Current THD	✓	✓	✗
16	System Voltage and Current THD	✓	✓	✓
17	Relay Limit State (on/off) / Timer Cycle count	✓	✓	✓

Electrical Connections

Network Types :

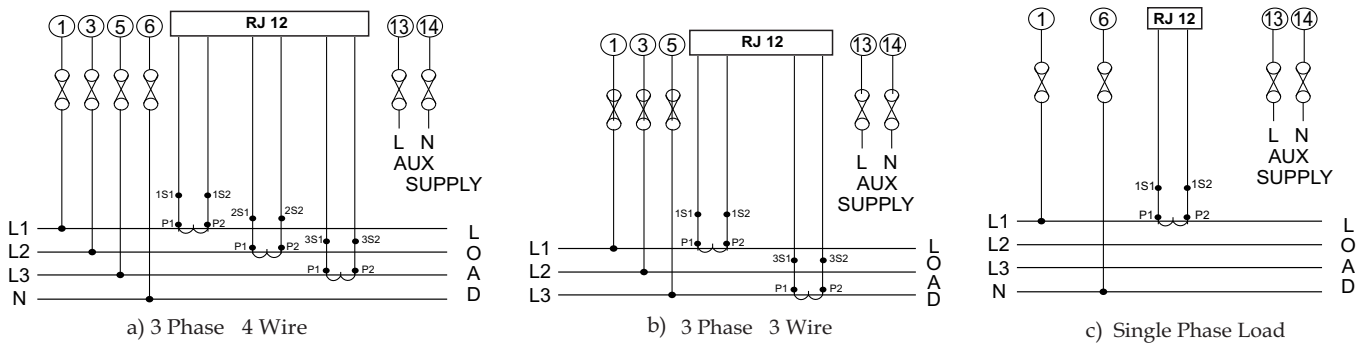

Dimensions

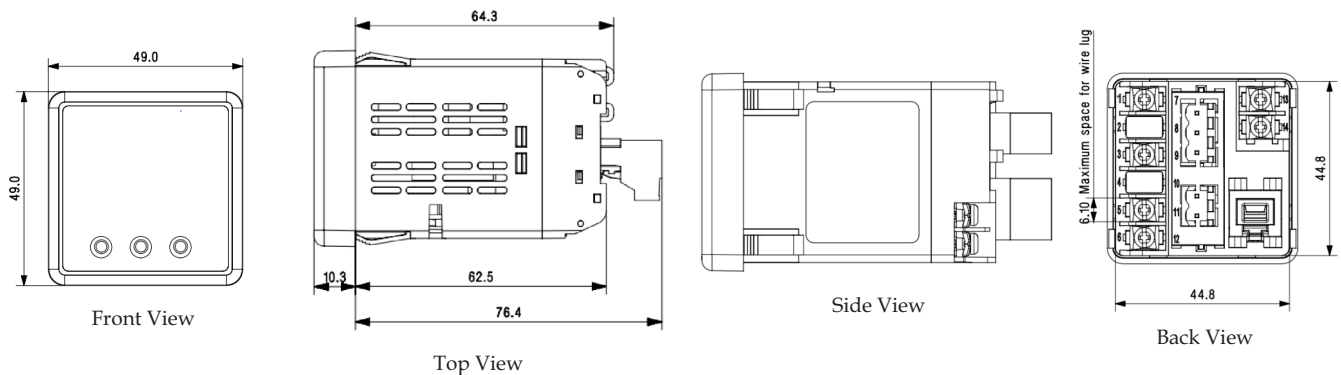

Installation

Installation

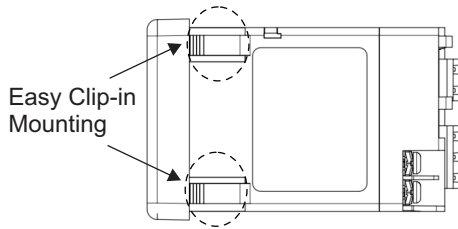

Terminal Details

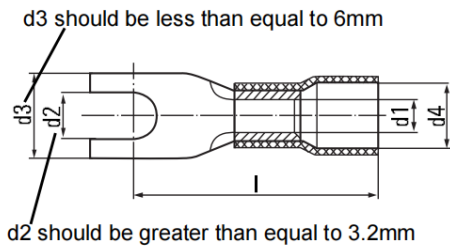
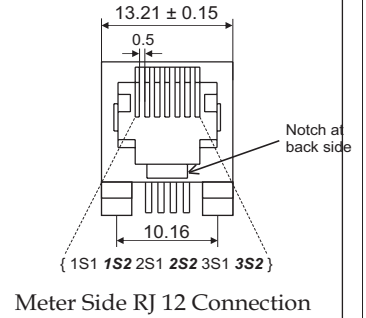
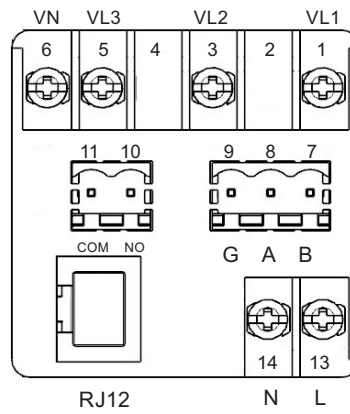

d3 should be less than equal to 6mm

d2 should be greater than equal to 3.2mm

Lug for Aux and Voltage Connections

Note:

1. RJ 12 Cable locking provision is provided with cable tie.
2. Max length of RJ Cable should be 2m.
3. For MODBUS B refers to Positive, A refers to Negative and G refers to ground.
4. Use Stranded wires for terminal connections.

Ordering information

Product Code	AV00-	S	5	3	3	1	X	X	1000ST
Size	48 X 48 mm								
Accuracy Class	Class 0.5								
System Type	3 Phase (On site configurable as 1 / 3 Phase)								
Input Voltage	100-500V L-L (On site configurable)								
Input Current	RJ12-100mA AC RMS								
Output Option	RS485 - 1 Relay Not Required						R Z		
Aux Voltage	60-280V AC/DC 20-60V AC/DC							H L	

Order Code Example

AV00-S5331RH1000ST - 48 x 48mm, 3 Phase, 100 - 500VLL, RJ12 100mA AC RMS, RS485 communication + 1 Relay Output, 60V - 280V AC/DC, Class 0.5,



Sifam Tinsley Instrumentation Inc.
2105, Barrett Park Dr. Unit 105.
Kennesaw, GA 30144, USA
E-mail Id : psk@sifamtinsley.com
info@sifamtinsley.com
Web : www.sifamtinsley.com
Contact No. : +1 404 736 4903

Sifam Tinsley Instrumentation Ltd
Unit 1 Warner Drive,
Springwood Industrial Estate
Braintree, Essex, UK, CM72YW
E-mail: sales@sifamtinsley.com
Web: www.sifamtinsley.com/uk
Contact: +44(0)1803615139