



**ONE-CHANNEL
DIGITAL-TO-ANALOGUE METER
WITH A MULTICOLOURED
BARGRAPH AND A SERIAL
INTERFACE
NA5 TYPE**



USER'S GUIDE



***One-channel digital-to-analogue meter
with multicoloured bargraph and a interface
NA5 TYPE***

USER'S GUIDE

CONTENTS	Page
1. APPLICATION	5
2. SET OF THE METER	6
3. BASIC REQUIREMENTS, OPERATIONAL SAFETY	7
4. INSTALLATION.....	9
5. SERVICING	13
6. RS-485 INTERFACE	31
7. TECHNICAL DATA.....	49
8. BEFORE A FAILURE HAS BEEN DECLARED	53
9. EXAMPLES OF NA5 METER PROGRAMMING.....	55
10. ORDERING PROCEDURE	58
11. MAINTENANCE AND GUARANTEE.....	60

1. APPLICATION

NA5 series meters with multicoloured bargraphs have an universal input destined to measure temperature, resistance, voltage from shunts, standard signals, d.c. voltage and d.c. current.

They can find application in various industrial fields, e.g. food industry, intermediate pumping stations, sewage treatment plants, chemical industry, weather stations, breweries.

They are destined for the visualisation of the measured value and evaluation of change trends of checked technological processes. They can also find application in automation systems where programmed controllers are applied.

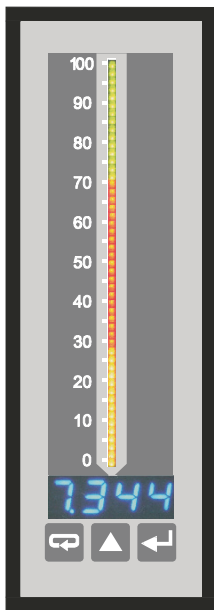

Fig.1. View of the NA5 meter.

NA5 meters can have in option: a continuous analogue output, a relay output, open collector (OC) type outputs and an RS-485 digital output.

They are programmed by means of the keyboard and through RS-485.

NA5 meters realise following functions:

- measurement of the input quantity and displaying it on the display and the bargraphs,
- recounting of the input signal into indication on the base of the individual linear characteristic,
- arithmetical functions: raising to a power, extraction of roots,
- programming of colours and bargraph resolutions,
- signalling of alarm value setting exceedings,
- recording of the measured signal in programmed time segments,
- storage of maximal and minimal values,
- programming of the measurement averaging time,
- programming of the indication resolution,
- deadlock of the parameter introduction by means of a password,
- conversion of the measured quantity into a voltage or current output signal,
- service of the RS-485 interface in MODBUS protocol, both in ASCII and RTU mode.

2. SET OF THE NA5 METER

We deliver in the set:

- | | |
|---|-------------------------------------|
| - NA5 meter | 1 pc. |
| - user's guide | 1 pc. |
| - guarantee card | 1 pc. |
| - plug with screw terminals | 1 or 2 pcs (depending on execution) |
| - holders to fix the meter in the panel | 2 pcs |
| - set of stickers with units | 1 pc. |

When unpacking the meter, please check whether the type and execution code on the data plate correspond to the order.

3. BASIC REQUIREMENTS, SAFETY INFORMATION

Symbols located in this service manual mean:

WARNING!



Warning of potential, hazardous situations. Especially important. One must acquaint with this before connecting the NA5 meter. The non-observance of notices marked by these symbols can occasion severe injuries of the personnel and the damage of the instrument.

CAUTION!



Designates a general useful note. If you observe it, handling of the meter is made easier. One must take note of this when the instrument is working inconsistently to the expectations.

Possible consequences if disregarded !

In the security scope the meter meets the requirements of the EEC Low-Voltage directive (EN 61010 -1 issued by CENELEC).

Remarks concerning the operator safety:



1. General

- The NA5 meter is destined to be mounted on a panel.
- Non-authorized removal of the required housing, inappropriate use, incorrect installation or operation creates the risk of injury to personnel or damage to equipment. For more detailed information please see the user's guide.
- All operations concerning transport, installation, and commissioning as well as maintenance must be carried out by qualified, skilled personnel and national regulations for the prevention of accidents must be observed.
- According to this basic safety information, qualified, skilled personnel are persons who are familiar with the installation, assembly, commissioning, and operation of the product and who have qualifications necessary for their occupation.

2. Transport, storage

Please observe the notes on transport, storage and appropriate handling. Observe the climatic conditions given in Technical Data.

3. Installation

- The NA5 meter must be installed according to the regulation and instructions given in this user's guide.

- Ensure proper handling and avoid mechanical stress.
- Do not bend any components and do not change any insulation distances.
- Do not touch any electronic components and contacts.
- Instruments may contain electrostatically sensitive components, which can easily be damaged by inappropriate handling.
- **Do not damage or destroy any electrical components since this might endanger your health!**

4. Electrical connection

- Before switching the meter on, one must check the correctness of connection to the network.
- In case of the protection terminal connection with a separate lead one must remember to connect it before the connection of the instrument to the mains.
- When working on live instruments, the applicable national regulations for the prevention of accidents must be observed.
- The electrical installation must be carried out according to the appropriate regulations (cable cross-sections, fuses, PE connection). Additional information can be obtained from the user's guide.
- The documentation contains information about installation in compliance with EMC (shielding, grounding, filters and cables). These notes must be observed for all CE-marked products.
- The manufacturer of the measuring system or installed devices is responsible for the compliance with the required limit values demanded by the EMC legislation.

5. Operation

- Measuring systems including NA5 meters must be equipped with protection devices according to the corresponding standard and regulations for prevention of accidents.
- After the instrument has been disconnected from the supply voltage, live components and power connections must not be touched immediately because capacitors can be charged.
- The housing and the door must be closed during operation.

6. Maintenance and servicing

Please observe the manufacturer's documentation.

Read all product-specific safety and application notes in this user's guide manual

- Before taking the meter housing out, one must turn the supply off.
- The removal of the instrument housing during the guarantee contract period may cause its cancellation.

4. INSTALLATION

4.1. Fitting

Prepare a $(44^{+0.5} \times 137.5^{+0.5})$ mm hole in the panel. The thickness of the material from which the panel is made should be in the range 1...45 mm.

The meter has screw terminal strips which enable the connection of 2.5 mm^2 cross-section external conductors.

Meter dimensions are shown on the fig. 2.

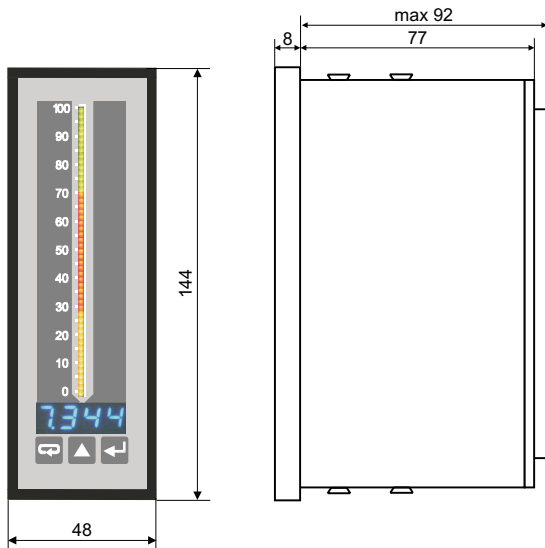

Fig. 2. Meter overall dimension

4.2. External connection diagrams

The description of terminal strips are shown on the fig. 3a.

Connections of input signals are shown on the fig 3b and output signals on fig. 3c and 3d.

The meter has programmable inputs. Maximal measuring ranges are given on figures.

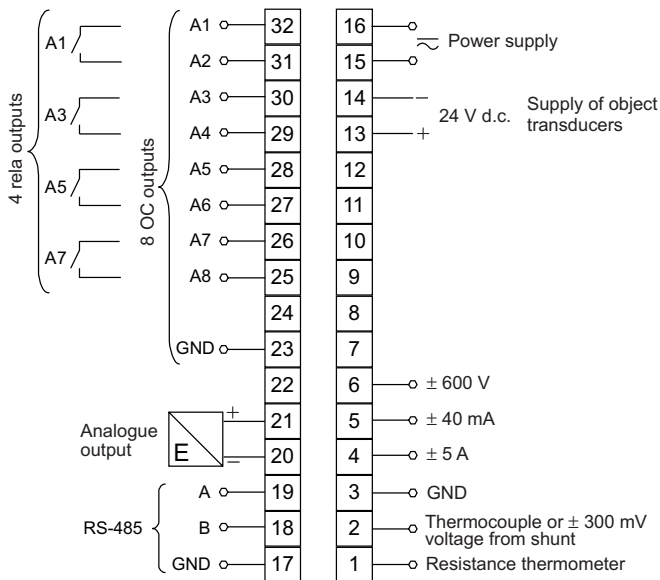

a/ Description of the terminal strip

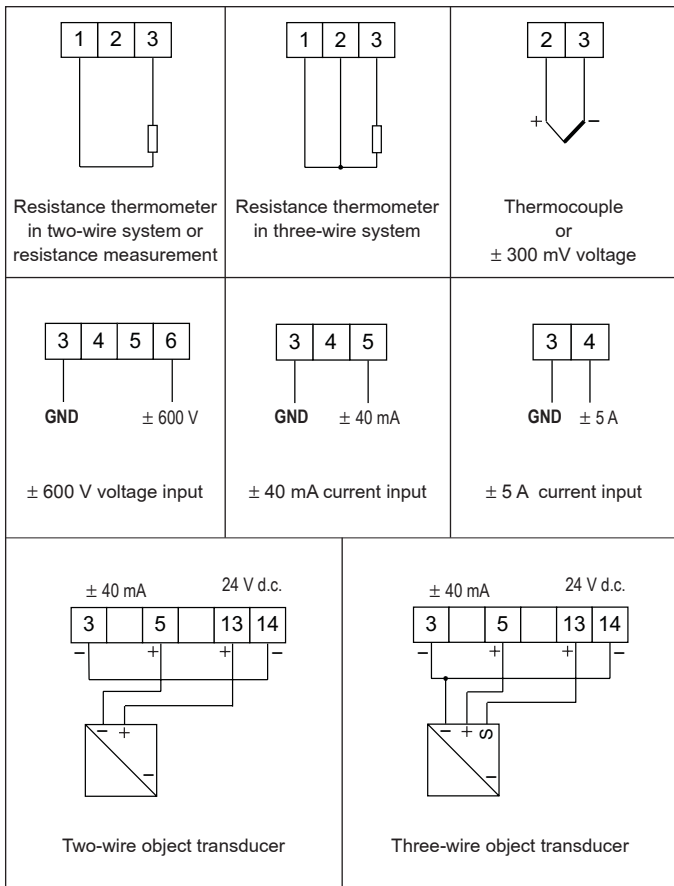

b/ Connection way of input signals

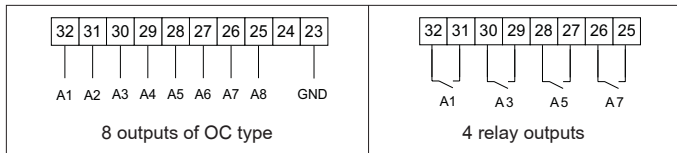

c/ Connection way of digital and analogue output signals depending on the execution code

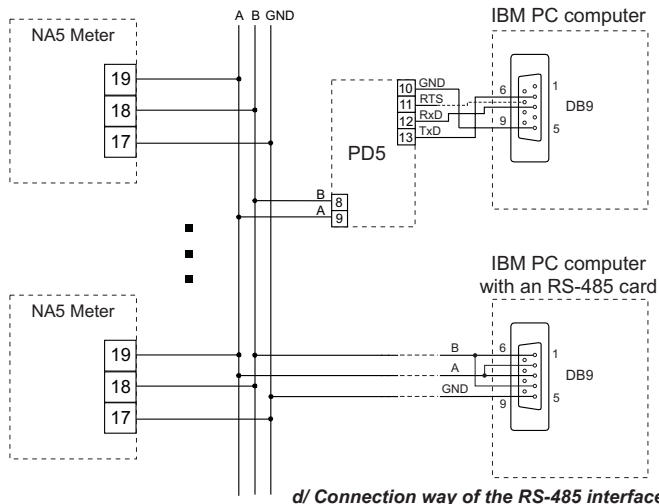

Fig.3 External connections of the NA5 meter

Taking into consideration electromagnetic interference it is recommended to use shielded conductors for the connection of input and output signals.

The power supply must be connected by means of a two-wire conductor with a suitable cross-section ensuring its protection by means of an installation fusible cut-out, in case of a short-circuit. Requirements concerning the supply cable are regulate by EN 61010-1 p.6.10 standard.

5. SERVICING

After connecting external signals and switching the meter on, its name *NA-5* and also the current version of the program, e.g. *v 100*, are displayed.

After ca 3 seconds, the meter transits automatically into the working mode in which it carries out the measurement and the display of the measured value on the display and the bargraph.

Depending on alarm parameter settings, the resolution and bargraph type, alarm thresholds are also displayed on the bargraph.

The meter blanks automatically insignificant zeros.

Key functions:

55-element bargraph (in three-colour execution)

29-element bargraph (in seven-colour execution)

Upper alarm threshold

Lower alarm threshold

Display

Acceptation key

Escape key

Value increasing key

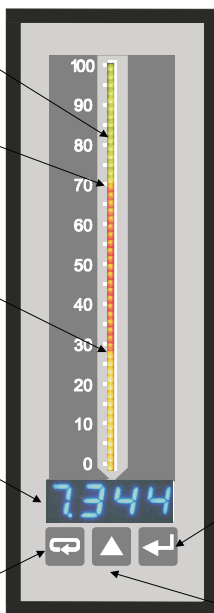

Fig. 4 Description of the NA5 frontal plate.



- acceptance key

- entry into the programming mode (hold down during ca 3 seconds),
- entry into the chosen parameter level,
- entry into the changing mode of the parameter value,
- acceptance of the changed parameter value.



- Key to increase the value



- display of the minimal value (first pressure), maximal (second pressure), return to measurement (third pressure),
- mowing on the preview menu or programming matrix,
- change of the chosen parameter value - increasing of the value.





- Escape key

- entry into the menu of recording results,
- entry into the preview menu or programming matrix,
- exit from the preview menu or programming matrix,
- escape from the parameter change.



The pressure and hold down the  key during 3 seconds causes the entry into the programming mode. The programming mode is protected by the **SEC** safety code.

The pressure and hold down the  key during 3 seconds causes the entry into the preview menu and the menu of recorded values. One must move on the preview menu by means of the  key. In this menu, only all programmed parameters except servicing parameters, are accessible to readout.

The exit from the preview menu is operated by means of the  key. It is also possible in the preview menu to review recorded **RESL** values.

The pressure of the  key on the **RESL** parameter causes the entry into the pre-

view menu of recorder values. The recorded result number is displayed alternately with the value e.g. *n320/2 174*.

The moving on recorded values follows by means of the  key. The pressure of this key longer than ca 2 seconds will cause the acceleration of the review. The pressure of the  key in any moment will cause the lighting of the number of recorded results. The exit from the review of recorded values is operated by means of the  key.

The algorithm of the meter servicing is presented on the fig. 5.

The appearance of the following symbols and inscriptions on the display means:

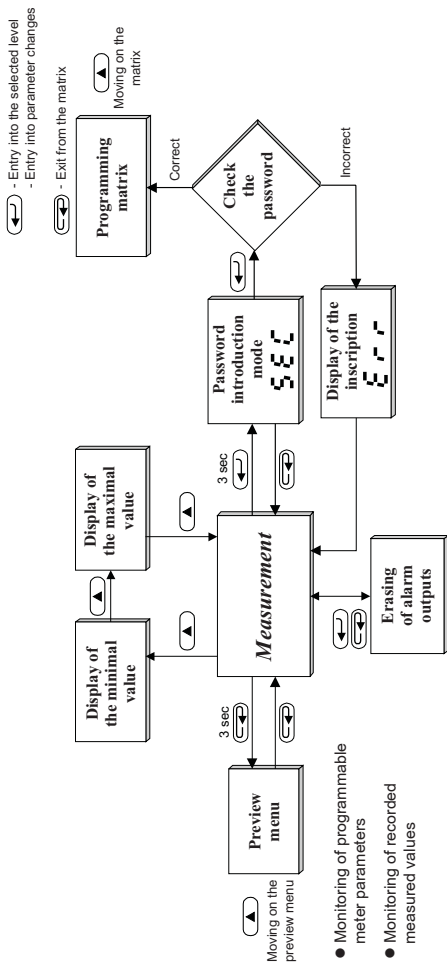

Fig 5. Servicing algorithm of the NA5 meter.

It is possible to change meter parameters:

- from the meter keyboard (p 5.1)



Incorrectly introduced safety code



Exceeding of the upper measuring range or lack of sensor



Exceeding of the lower measuring range or short-circuited sensor





Error of the conductor resistance compensation. No connected conductor or damaged conductor.



- through RS-485 (p.6.)

5.1. Change of the NA5 meter parameters from the keyboard

The pressure of the  key during circa three seconds causes the display of the **5E.C.**

Inscription alternately with the set zero value by the manufacturer. The introduction of the correct code causes the entry into the programming mode. The fig.6 represents the transition matrix into the programming mode. One can move on groups of main parameters eg: **Ch1, Ch2, bAr1, bAr2, AI1, AI2**, etc, by means of the  key.

The pressure of the  key on the given level, causes the entry into parameters of this level. The moving on the given level is operated by means of the  key.

In order to change the value, one must use the  key. In order to escape from the parameter change, one must press the  key.

By means of the  key, one can exit from the selected level and programming matrix to the measurement.

Fig. 6. Transition matrix into the programming mode

Main menu		Parameters of the selected level											
Lev. Nr		tyP	Lo:n	H:i:n	Func	Con	d.p	Cnt	:nd:	:.H:	d.y:	:.H2	d.y2
		Input type	Lower value of input range	Upper value of input range	Mathem. func.	Kind of comp.	Decim. point	Meas. time	Input ind. charact.	Param. of ind. charact.	Param. of ind. charact.	Param. of ind. charact.	Param. of ind. charact.
1	Chn												
2	bARL	tyPb Bargr. type	colr Bargr. colour	brL Lower bargr.	brH Upper bargr.								
3	AL1												
÷													
10	AL8	P-rL Lower threshold	P-rH Upper threshold	tYPA Alarm type	dLY Alarm delay	HOld Alarm support	CurL Lower marker colour	CurH Upper marker colour					
11	Out	:nd0 Input indiv. charac.	d.H1 Param. indiv. charac.	0.Y1 Param. indiv. charac.	d.H2 Param. of indiv. charac.	0.Y2 Param. of indiv. charac.	bRud Baud rate	t-rYb Kind of transm.	Rdr Device address				
12	SEr	SEt Param. inscript.	SEc Passw. change	tSt Test of display + bargr.	Hour Time change	CLrL Erasing of min. value	CLrH Erasing of max. value						
13	LOGr	rEC Record.	Cor1 Chan.1 record. start	dRE1 Chan.1 record. date	:nt1 Chan.1 record. interv.								

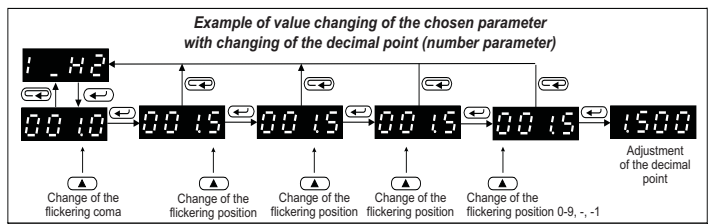
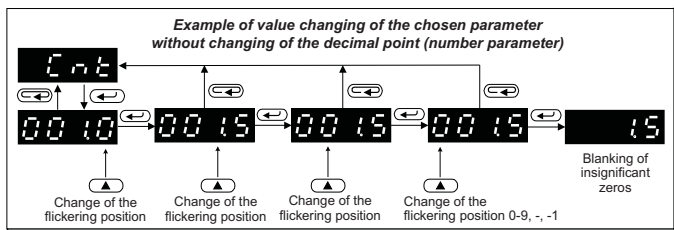
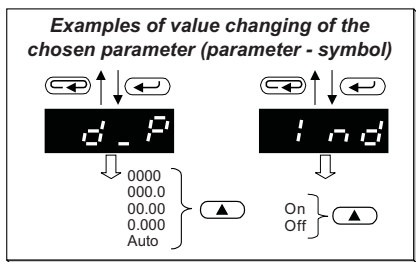



Fig. 7.

Meter programmable parameters are presented in the table 1. The programming of parameters is possible after the previous introduction of the password.

	Symbol on the display	Parameter description	Range of changes
Input parameter	tYP	Kind of input	Reesistance thermometers: Pt 1 - Pt100 Pt 5 - Pt500 Pt 10 - Pt1000 Thermocouples: tE - j - thermocouple, type J tE - h - thermocouple, type K tE - n - thermocouple, type N tE - E - thermocouple, type E tE - r - thermocouple, type R tE - S - thermocouple, type S tE - t - thermocouple, type T rE2 - resistance to 10 kΩ nRPL - voltage to ± 300 mV nRPH - voltage to ± 600 V nnRL - current to ± 40 mA nnRH - current to ± 5 A
	Lo:n	Lower value of the input range The setting of parameters LoIn and HiIn gives the possibility to narrow the measuring range down.	Setting possibility: -1999... 9999 At the input signal < LoIn the meter displays the lower exceeding. The condition LoIn < HiIn must be fulfilled. The parameter does not take into consideration the individual characteristic, is operates on the measuring signal.
	Hi:n	Upper value of the input range.	Setting possibility: -1999... 9999 At the input signal > HiIn the meter displays the upper exceeding. The condition LoIn < HiIn must be fulfilled. The parameter does not take into consideration the individual characteristic, is operates on the measuring signal.
	Func	Mathematical functions	OFF - mathematical functions switched off; 50r - raising to a power (result) ² 50rt - extraction of roots $\sqrt{\text{result}}$

Input parameter	Con	<p>Kind of compensation of sensor working conditions changes:</p> <ul style="list-style-type: none"> - In case of a resistance thermometer and resistance measurement, it concerns the compensation of the resistance changes of the conductor linking the sensor with the meter, - In case of a thermocouple it concerns the compensation of reference 	<p>Auto - automatic compensation (in case of resistance thermometers and resistance measurement it requires a 3-wire line.)</p> <p>0.0...60.0°C - value of the reference temperature for thermocouples.</p> <p>0.0...40.0 Ω - resistance of two conductors for resistance thermometers and resistance measurement.</p> <p>The writing of a value beyond the interval of manual compensation (e.g. value 70.0) will cause the automatic compensation switching on.</p>
	d.p	<p>Setting of the decimal point. The setting operates both when the individual characteristic is switched off and on. The introduction of the decimal point making impossible the display of four characters on the display will cause the display of the lower or upper exceeding.</p>	<p>Setting possibility:</p> <p>0000 000.0 00.00 0.000</p> <p>Auto - automatic choice of the decimal point</p>
	Cnt	<p>Averaging time of the measurement.</p>	<p>0.0...999.9 s</p> <p>The writing of 0 causes the switching of the measurement off and the stoppage of the meter operation. In this state, the meter displays the hour. The bargraph is blank.</p>
	IndI	<p>The switching off or on of the individual linear user's characteristic. - („Individual characteristic of the display”).</p>	<p>On - characteristic switched on, OFF - characteristic switched off.</p>
	1.H1 d.Y1 1.H2 d.Y2	<p>Parameters of the display individual characteristic.</p> <p>On the base of given by the user coordinates of two points the meter determines (from the system of equations) a and b coefficients of the individual characteristic.</p> $\begin{cases} d_Y1 = a \cdot I_H1 + b \\ d_Y2 = a \cdot I_H2 + b \end{cases}$ <p>Where: I_H1 i I_H2 - measured value d_Y1 i d_Y2 - expected value on the display. Fig.9 shows the way of the individual</p>	<p>Setting possibility: -1999... 9999</p>





Bargraph Parameters bArL	tyPb	Bargraph type	<p>OnEC - „one colour „ bargraph, :ntc - „ interval „ bargraph, SEct - „ sector” bargraph, P:nt - „ point bargraph, tREn -”trend” bargraph.</p> <p>Fig. 10 explains bargraph types. .</p>
	colr	Bargraph colour	<p>OFF - bargraph switched off, r - red, G - green, rG - red + green other colours are accessible only in meters with a 7-colour bargraph.</p> <p>b - blue, rb - red + blue, Gb - green + blue, rGb - red + green + blue.</p>
	brL	<p>Parameter to set the „magnifier” on the bargraph. Lower threshold.</p> <p>Value on the display at which the bargraph is to be blank.</p>	Setting possibility: -1999... 9999
	brH	<p>Parameter to set the „magnifier” on the bargraph. Upper threshold.</p> <p>Value on the display at which the bargraph is to be lighted.</p>	Setting possibility: -1999... 9999

PrL	Lower alarm threshold	Setting possibility: - 1999... 9999
PrH	Upper alarm threshold	Setting possibility: - 1999... 9999
tYPR	Alarm type Fig. 8 shows alarm types	nor - normal, On - switched on, OFF - switched off, H_On - manually switched on. Till the time of the alarm type change, the alarm output is being permanently switched on. H_OF - manually switched off. Till the time of the alarm type change, the alarm output is being permanently switched off.
dLY	Delay of the alarm operation. The parameter is defined in seconds, i.e. one must give the time in seconds after which the alarm will operate after its occurrence. The alarm operation follows after the measurement averaging. The alarm switching off follows without delay..	0.0... 999.9 Introduction of 0.0 causes the operation at the moment of the alarm occurrence.
HOLD	Support of alarm signalling. In the situation when the holding function is switched on, after the alarm state stoppage, the alarm is still switched on (relay or OC contacts). The alarm state is active till the moment of erasing it by means of the combination of  and  keys.	OFF - The maintenance of the alarm output is switched off. On - The maintenance of the alarm output is switched on.

Curl	Colour of the lower threshold alarm marker.	OFF - alarm marker switched off. r - red,
CurH	Colour of the upper threshold alarm marker.	G - green, rG - red + green, Other colours are accessible only in meters with a 7-colour bargraph. b - blue, rb - red + blue, Gb - green + blue, rGb - red + green + blue, Fig. 10 explains the idea of Curl and CurH parameters

Output parameters	indO	Switching off or on of the individual linear user's characteristic - (individual characteristic of the analog output).	On - characteristic switched on, OFF - characteristic switched off . When the characteristic is switched off, the meter operates at the maximal range depending on input and range output.
	d-H1 O-Y1 d-H2 O-Y2	Parameters of the individual characteristic of the analog output. On the base of given coordinates of two points by the user, the meter determines (from the equation system) coefficients a and b of the individual characteristic. $\begin{cases} O_Y1 = a \cdot d_H1 + b \\ O_Y2 = a \cdot d_H2 + b \end{cases}$ where: d_H1 and d_H2 - displayed value O_Y1 and O_Y2 - expected value on the analog output. Fig. 9 represents the graphical illustration explaining the idea of the individual characteristic.	Setting possibility: - 1999... 9999

bAud	Baud rate of the RS-485 interface.	2400 - 2400 b/s 4800 - 4800 b/s 9600 - 9600 b/s
trYb	Kind of transmission through the RS-485 interface.	OFF - interface switched off R8n1 - ASCII 8N1 R7E1 - ASCII 7E1 R7o1 - ASCII 7O1 r8n2 - RTU 8N2 r8E1 - RTU 8E1 r8o1 - RTU 8O1 r8n1 - RTU 8N1
Adr	Device address	Setting possibility: 0...247

Servicing parameters	SEt	Manufacturer's parameters. Manufacturer's parameters are presented in the table 2.	The pressure of the  key causes the writing of manufacturer's para-
	SEc	Introduction of a new password.	Setting possibility: - 1999... 9999
	tSt	Test of displays and bargraphs. The Test consists on a successive display of numbers 1111, 2222 etc. Successive bargraph colours are lighted on the bargraph.	The pressure of the  key causes the test switching on. The pressure of the
	Hour	Setting of the current time. Time format : hh:mm:ss	Setting possibility: 00:00:00 ...
	CLrL	Erasing of the minimal value.	The pressure of the  key causes the
	CLrH	Erasing of the maximal value.	The pressure of the  key causes the

Recording parameters	rEE	Switching the recording on or off. At the moment of switching the recording on, the meter erases the previous stored values.	OFF - recording switched off ON - recording switched on
	Lo.r	Hour of recording start Time format: hh:mm:ss	Setting possibility: 00:00:00 ... 23:59:59
	dAtE	Date of recording start Date format: yy.mm.dd It is an information parameter. It not serves to define the date from which the recording is to begin, but only to inform when the recording	Setting possibility: 70.01.01 ... 38.12.31
	intE	Recording time interval Defines the segment of time and at which sequence the result will be to memorised. Minimal interval 1 s. Format: hh:mm:ss	Setting possibility: 00:00:00 ... 99:59:59

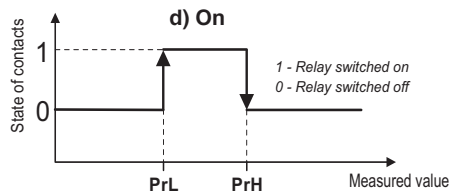
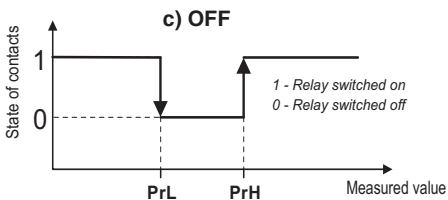
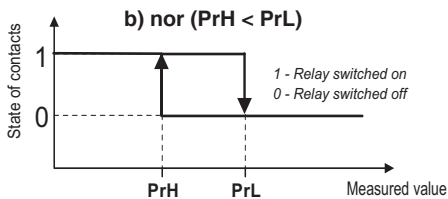
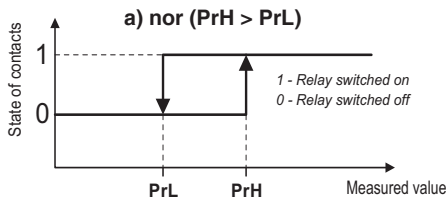
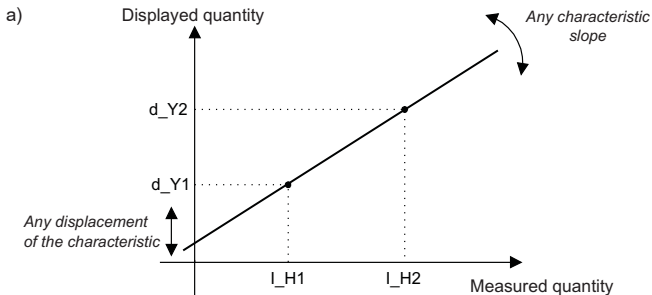
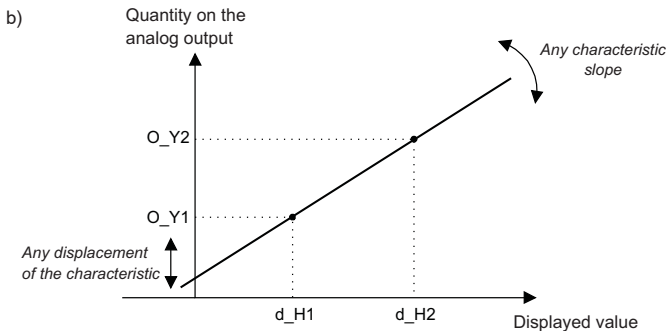

Fig. 8. Alarm types: a, b - normal, c - switched off, d - switched on



Value I_{H1} on the meter input => value d_{Y1} on the display.
 Value I_{H2} on the meter input => value d_{Y2} on the display
 other characteristic points are calculated



Value d_{H1} on the display => value O_{Y1} on the analogue output.
 Value I_{H2} on the display => value O_{Y2} on the analogue output
 other characteristic points are calculated

Fig. 9. a) Individual characteristic of the display, b) Individual characteristic of the analogue output.

Type of bargraph	Exemplary settings of the bargraph and the alarm, ex. 1 $\xi_{urL} = G$ (green) $\xi_{urL} = r$ (red) $\xi_{urH} = rG$ (red+green)	Notes
<i>OnE</i>		
<i>intr</i>		Value under the value P_{rL}
		Value between P_{rL} and P_{rH}
		Value over P_{rH}
<i>SEct</i>		
<i>PInt</i>		
<i>trEn</i>		Value without changes in time
		Value increases
		Value decreases

Fig. 10. Bargraph modes.



Notice!

- The meter is working in the measuring range of defined indications by the user in **LoIn** and **HiIn** parameters. Below and over, it shows a range exceeding.
- In case when the meter is working with a resistance thermometer in a two-wire system, the choice of the automatic compensation option of conductor resistance changes will cause a defective meter operation and the display of **ErrC** inscription.
- In case of the display individual characteristic switching on, the result on the display is linearly converted according to the introduced parameters: **I_H1**, **I_H2**, **d_Y1** and **d_Y2**.
- In case of arithmetical functions and individual characteristic switching on, in the first sequence, arithmetical operations will be carried out and the obtained result is converted by the individual characteristic.
- In case of the analog output individual characteristic switching on, the measurement result is linearly converted according to the introduced parameters: **d_H1**, **d_H2**, **O_Y1** i **O_Y2**.

- The meter currently checks the value of the introduced parameter at the moment. In case when the introduced value exceeds the upper or the lower range of changes given in the table 1, the meter will not make the parameter record.
- In case of the **Input type** change, a simultaneous change of the decimal point follows, optimally for the given input.
- After the supply decay, the current time is reset.
- The recording switching off follows in following cases: switching the recording off from the programming matrix, change of the **input type**, change of the **recording time start** or the **recording time interval**, setting **Cnt=0**, filling of the memory, and at a renewed switching of the meter on to the network.
- In case of a **Intr** or **Sect** bargraph type, it is possible to set only one **CurL** and **Curh** markers (from one alarm). The others are automatically erased.
- Max and Min values are erased in case of changes: input type, individual characteristic (on, off), writing of standard parameters.

6. RS-485 INTERFACE

Standard parameters of the NA5 meter

Table 2

Parameter description	Standard value	Parameter description	Standard value
<i>tYP</i>	<i>nnRL</i> (± 40 mA)	<i>PrL</i>	- 20.00
<i>Lo:n</i>	- 20.0	<i>PrH</i>	20.00
<i>Hi:n</i>	20.00	<i>tYPR</i>	OFF
<i>Func</i>	OFF	<i>dLY</i>	0
<i>Con</i>	0 = manually	<i>HOLD</i>	OFF
<i>d.P</i>	00.00	<i>CurL</i>	r - Alarm 1 and 3 OFF-other alarms
<i>Cnt</i>	1.0	<i>CurH</i>	rG - Alarm 1 and 3 OFF-other alarms
<i>:nd:</i>	OFF	<i>:nd0</i>	OFF
<i>:.H1</i>	0	<i>d.H1</i>	0
<i>d.Y1</i>			
<i>:.H2</i>			
<i>d.Y2</i>			
<i>tYPb</i>	Sect	<i>d.H2</i>	0
<i>colr</i>	G	<i>d.Y2</i>	
<i>brL</i>	- 20.0	<i>bAud</i>	9600
<i>brH</i>	20.00	<i>trYb</i>	RTU 8N2

<i>Adr</i>	1	<i>DATE</i>	70:01:01
<i>SEC</i>	0	<i>:ntE</i>	00:15:00
<i>Hour</i>	00:00:00		
<i>rEE</i>	OFF		
<i>Cor.r</i>	00:00:00		

NA5 programmable digital meters have a serial link of RS-485 standard to communicate in computer systems and with other devices fulfilling the master function. The MODBUS asynchronous character communication protocol has been implemented on the serial link. The transmission protocol describes information exchange procedures between devices through the serial link.

6.1. Procedure of the serial interface connection

The RS-485 standard enables the direct connection to 32 devices on a single serial link up to a 1200 m distance. For the connection of a higher number of devices it is necessary to apply additional intermediate-to-separating systems.

The exit of the interface line is presented in the service manual on the fig. 3.d. In order to obtain a correct transmission it is necessary to connect lines **A** and **B** in parallel to their equivalent lines in other devices.

The connection must be made with a shielded conductor. The shield must be connected to the protective terminal in one point.

The **GND** line serves to the additional protection of the interface line at long distance connections.

One must connect GND signals between devices and in one point to the protective terminal (that is not necessary for the interface correct operation).

To obtain the connection with the computer of IBM PC class, an RS-232 into RS-485 converter is necessary or an RS-485 interface card. The way of NA5 meter connection through the PD5 converter is shown on the fig. 3d.

The designation of transmission lines for the card in the PC computer depends on the card producer.

6.2. Description of the MODBUS protocol implementation

The implemented protocol is compatible with the PI-MBUS-300 Rev G Modicon

Company specification.

Set of serial link parameters of meters in the MODBUS protocol:

- meter address - 1... 247
- baud rate - 2400, 4800, 9600 bit/s
- working mode - ASCII, RTU
- information unit - ASCII: 8N1, 7E1, 7O1
- RTU: 8N2, 8N1, 8E1, 8O1
- maximal response time 500 ms

The configuration of serial link parameters is described in the further part of the user's manual. It consists on the establishment of the baud rate (**bAud** parameter), device address (**Adr** parameter) and the type of information unit (**trYb** parameter).

Note:

Each meter connected to the communication network must have:

- a unique address, different from addresses of other devices connected in the network,
- an identical baud rate and information type.

6.3. Description of the MODBUS protocol functions

Following functions of the MODBUS protocol have been implemented in NA5 meters:

Function description

Table 3

<i>Code</i>	<i>Meaning</i>
03 (03 h)	Read-out of n-registers
06 (06 h)	Recording of a single register
16 (10 h)	Recording of n-registers
17 (11 h)	Identification of the slave device

The maximal number of registers for writing or readout by one order is equal 28.

Read-out of n-registers (code 03 h)

Function is inaccessible in the publication mode.

Example: readout of 2 registers beginning from the register with the address 1 DBDh (7613) in RTU mode.

Request:

Device address	Function	Register address		Number of registers		Check-sum CRC
		Hi	Lo	Hi	Lo	
01	03	1D	BD	00	02	52 43

Response:

Device address	Function	Number of bytes	Value from the register 1DBD (7613)				Value from the register 1DBE (7614)				Check-sum CRC
01	03	08	3F	80	00	00	40	00	00	00	42 8B

Record of values into the register (code 06h)

The function is accessible in the publication mode.

Example: record of the register of 1DBDh (7613) address in RTU

Request:

Device address	Function	Register address		Value from the register 1DBD (7613)				Check-sum CRC
		Hi	Lo					
01	06	1D	BD	3F	80	00	00	85 AD

Response:

Device address	Function	Register address		Value from the register 1DBD (7613)				Check-sum CRC
		Hi	Lo					
01	06	1D	BD	3F	80	00	00	85 AD

Record into n-registers (code 10h)

The function is accessible in the publication mode

Example: record of two registers beginning from the register with 1DBDh (7613) address in RTU mode.

Request:

Device address	Function	Register address		Number of registers		Number of bytes	Value for the register 1DBD (7613)				Value for the register 1DBE (7614)				Check-sum CRC
		Hi	Lo	Hi	Lo										
01	10	1D	BD	00	02	08	3F	80	00	00	40	00	00	00	03 09

Response:

Device address	Function	Register address Hi	Register address Lo	Number of registers Hi	Number of registers Lo	Checksum (CRC)
01	10	1D	BD	00	02	D7 80

Report identifying devices (code 11h) in RTU mode

Example: Data readout identifying the device for NA5 with a universal input.

Request:

Device address	Function	Checksum (CRC)
01	11	C0 2C

Response:

Device address	Function	Number of bytes	Device identifier	Device state	Field depending on the type of device	Checksum
01	11	08	81	FF	00XXXXXX	

Device address - depending on the setpoint

Function - no of function 0x11

Number of bytes - 0x08

Device identifier - 0x81

Device state - 0xFF

Field depending on the device type - XXXXXX

Device name - no taken advantage in NA5 meters, 00 X X X X X

Analogue output - field depending on the type of the analogue output

- 0x00 - lack of analogue output, X 00 X X X X

- 0x01 - voltage analogue output, X 01 X X X X

- 0x02 - current analogue output, X 02 X X X X

No. of the software program - software version implemented in the meter

- X X ___ _4 - byte variable of float type

Check sum - 2 bytes in case of work in RTU mode

- 1 byte in case of work in ASCII mode

Example:

Work in **RTU** mode: e.g. **Mode = RTU 8N2** (value 0x02 in case of readout/record through the interface).

NA5 meter

Execution with a voltage analogue output: **00**,

No. of the software version: **1.00**,

Device address set on: **Adr = 0 x 01**,

For such a meter the frame has the following form:

Device address	Function	Number of bytes	Device identifier	Device state	Field depending on the device type	Check-sum (CRC)
01	11	08	81	FF	00 00 3F 80 00 00	FE D7

6.4. Register map of NA5 meters

Register map of NA5 meters

Table 4.

Address range	Type of value	Description
7000-7200	Float (32 bits)	The value is placed in two successive 16-byte registers. Registers enclose the same data as 32-byte registers from the 7500 area. Registers are only for readout.
7200-7400	Float (32 bits)	The value is placed in two successive 16-bit registers. Registers enclose the same data as 32-bit registers from the 7600 area. Registers are only for readout.
7500-7600	Float (32 bits)	The value is placed in a 32-byte register. Registers are only for readout.
7600-7700	Float (32 bits)	The value is placed in a 32-bit register. Registers can be read out and recorded.

6.5. Registers for recording and readout

NA5 meter

The value is placed in two successive 16-bit registers enclosing the same data as 32-bit registers from the 7600 area	The value is placed in 32-bit registers	Symbol	Writing (w) Readout (r)	Range	Description	
		7200	7600	Identifier	r	-
					Value	
					81	NA5
7202	7601	Channel number	w/r	0...1	No occurs	
7204	7602	input	w/r	0...14	Channel input type <Channel number>	
					Value	
					0	Pt100 RTD
					1	Pt500 RTD
					2	Pt1000 RTD
					3	J thermocouple
					4	K thermocouple
					5	N thermocouple
					6	E thermocouple
					7	R thermocouple
					8	S thermocouple
					9	T thermocouple
					10	R. meas. up to 10 kΩ
					11	Volt. meas. to ± 300 mV
					12	Volt. meas. to ± 600 V
					13	Current meas. to ± 40 mA
					14	Current meas. to ± 5 A

7206	7603	LoIn	w/r	-1999... 9999	Lower value of the input range	
7208	7604	HiIn	w/r	-1999... 9999	Upper value of the input range	
7210	7605	Function	w/r	0... 7	Arythmetical function	
					Value	
					0	Switched off
					1	Squaring
					2	Extraction of roots
7212	7606	Compens.	w/r	-199.9... 999.9	Compensation of the conductor resistance or cold junction	
7214	7607	D_P	w/r	0... 4	Decimal point	
					Value	
					0	0000
					1	000.0
					2	00.00
					3	0.000
					4	Auto
7216	7608	Cnt	w/r	0... 999.9	Measurement time	
7218	7609	Indi	w/r	0... 1	Individual characteristic	
					Value	
					0	Switched characteristic off
					1	Switched characteristic on
7220	7610	X1 In	w/r	-1999... 9999	Parameters of the individual characteristic	
7222	7611	Y1 LED	w/r	-1999... 9999	Parameters of the individual characteristic	
7224	7612	X2 In	w/r	-1999... 9999	Parameters of the individual characteristic	
7226	7613	Y2 LED	w/r	-1999... 9999	Parameters of the individual characteristic	

7228	7614	No occurs					
7230	7615	Bargraph type	w/r	0... 4	Bargraph type		
					Value		
					0	One-colour (OnEC)	
					1	Change of colour after exceeding the alarm threshold (the colour change the whole bargraph) (Intr)	
					2	Change of colour after exceeding the alarm threshold (Three-segment change of colour) (SEct)	
					3	One-colour bargraph, alarm markers in another colour (PInt)	
					4	Increasing/decreasing trend (trEn)	
7232	7616	Colour	w/r	0... 7	Bargraph colour		
					Value		
					0	Bargraph off (OFF)	
					1	Red (r)	
					2	Green (G)	
					3	Red + Green (rG)	
					Other values are only accessible in meters with RGB diodes		
					4	Blue (b)	
					5	Red + Blue (rb)	
					6	Green + blue (Gb)	
7	Red + Green + Blue (rGb)						
7234	7617	Brl	w/r	-1999... 9999	„Magnifier” on the bargraph Lower threshold		
7236	7618	Brh	w/r	-1999... 9999	„Magnifier” on the bargraph Upper threshold		
7238	7619	Alarm number	w/r	0... 7	Choice of alarm number		
					Range of changes is depended on the meter execution code (number of alarms)		

7240	7620	No occurs				
					Value	
					0	Channel 1
					1	Channel 2
7242	7621	Prl	w/r	-1999... 9999	Alarm lower threshold <Alarm No>	
7244	7622	Prh	w/r	-1999... 9999	Alarm upper threshold <Alarm No>	
7246	7623	Type a	w/r	0... 4	Alarm type <Alarm No>	
					Value	
					0	Normal
					1	Switched on
					2	Switched off
					3	Manually switched on
					4	Manually switched off
7248	7624	Alarm delay	w/r	0... 999.9	Alarm delay <Alarm No>	
7250	7625	Alarm support	w/r	0... 1	Alarm signalling support <Alarm No>	
					Value	
					0	Support switched off
					1	Support switched on
7252	7626	CURL	w/r	0... 7	Bargraph colour to the lower alarm threshold < Alarm Nr >	
					Value	
					0	Bargraph switched off (OFF)
					1	Red (r)
					2	Green (G)
					3	Red + Green (rG)
					Other values accessible only in meters with RGB diodes	
					4	Blue (b)
					5	Red + Blue (rb)
					6	Green + blue (Gb)
7	Red + Green + Blue (rGb)					

7254	7627	CURH	w/r	0... 7	Bargraph colour after exceeding the upper alarm threshold <Alarm No>	
					Value	
					0	Bargraph switched off (OFF)
					1	Red (r)
					2	Green (G)
					3	Red + Green (rG)
					Other values accessible only in meters with RGB diodes	
					4	Blue (b)
					5	Red + Blue (rb)
					6	Green + blue (Gb)
					7	Red + Green + Blue (rGb)
7256	7628	No occurs				
7258	7629	Output characteristic	w/r	0... 1	Characteristic of the analogue output	
					Value	
					0	Characteristic switched off
					1	Characteristic switched on
7260	7630	X1 LED	w/r	- 1999... 9999	Parameters of the analogue output characteristic	
7262	7631	Y1 Out	w/r	- 1999... 9999	Parameters of the analogue output characteristic	
7264	7632	X2 LED	w/r	- 1999... 9999	Parameters of the analogue output characteristic	
7266	7633	Y2 Out	w/r	- 1999... 9999	Parameters of the analogue output characteristic	
7268	7634	Baud rate	w/r	0... 2	Baud rate of the RS-485 interface	
					Value	
					0	2400 bit/s
					1	4800 bit/s
					2	9600 bit/s
7270	7635	Working mode	w/r	0... 7	Working mode of the MODBUS protocol	
					Value	
					1	ASCII 8N1
					2	ASCII 7E1
					3	ASCII 7O1
					4	RTU 8N2

					5	RTU 8E2
					6	RTU 802
					7	RTU 8N1
7272	7636	Address	w/r	0... 247	Choice of the device address	
7274	7637	Test	w/r	0... 1	Test of the display	
					Value	
					0	Lack of operation
					1	Test
7276	7638	Hour	w/r	0... 23.5959	Current time	
					<p>This parameter occurs with four places after the decimal point in format gg,mmss, where:</p> <p>gg - means hours, mm - means minutes, ss - means seconds</p> <p>In case when introducing and incorrect time, the indicator will correct it automatically.</p>	
7278	7639	Recording	w/r	0... 1	Registration of measured value	
					Value	
					0	Recording switched off
					1	Recording switched on
7280	7640	Interval	w/r	0... 99.5959	Time interval of the recording	
7282	7642	Recording time	w/r	0... 23.5959	Time of the recording start	
					<p>This parameter occurs with four places after the decimal point in format gg,mmss, where:</p> <p>gg - means hours, mm - means minutes, ss - means seconds</p> <p>In case when introducing and incorrect time, the indicator will correct it automatically.</p>	
7284	7642	Year	w/r	1970... 2038	Year of the recording start	
7286	7643	Month	w/r	1... 12	Month of the recording start	

7288	7644	Day	w/r	1... 31	Day of the recording start	
					Year, Month, Day are information parameters (they do not serve to define the date from which the recording is to be start).	
7290	7645	Erasing of minimum	w/r	0... 1	Erasing of the minimal value	
					Value	
					0	Lack of operation
					1	Erasing
7292	7646	Erasing of maximum	w/r	0... 1	Erasing of the maximal value	
					Value	
					0	Lack of operation
					1	Erasing
7294	7647	No occurs				
7296	7648	No occurs				

7320	7660	Year of the memorised value	w/r	1970... 2038	Year of memorised value in memory	
7322	7661	Month of the memorised value	w/r	1... 12	Month of memorised value in memory	
7324	7662	Day of the memorised value	w/r	1... 31	Day of memorised value in memory	

7326	7663	Time of the memorised value	w/r	0... 23.5959	Time of memorised value in memory																		
					<p>This parameter occurs with four places after the decimal point in format gg,mmss, where gg - means hours, mm - means minutes, ss - means seconds</p> <p>In case when introducing and incorrect time, the meter will correct it automatically.</p>																		
7328	7664	Index of the memorised value	w/r	1... 750	Number of memorised value in memory																		
7230	7665	Status	w/r	0... 7	Operation status on the buffer																		
					<table border="1"> <thead> <tr> <th>Value</th> <th></th> </tr> </thead> <tbody> <tr> <td>0</td> <td>Lack of operation</td> </tr> <tr> <td>1</td> <td>Searching acc. date and time (registers nr 7660...7663 and 7320...7326)</td> </tr> <tr> <td>2</td> <td>Searching acc. time (registers nr 7663 and 7326)</td> </tr> <tr> <td>3</td> <td>Searching acc. index (registers nr 7664 and 7328)</td> </tr> <tr> <td>4</td> <td>Load next values into the buffer (registers 7672...7691 and 7344...7382)</td> </tr> <tr> <td>5</td> <td>Load previous values into the buffer (registers 7672...7691 and 7344...7382)</td> </tr> <tr> <td>6</td> <td>Go to the first memorised value in memory.</td> </tr> <tr> <td>7</td> <td>Go to the last memorised value in memory.</td> </tr> </tbody> </table>	Value		0	Lack of operation	1	Searching acc. date and time (registers nr 7660...7663 and 7320...7326)	2	Searching acc. time (registers nr 7663 and 7326)	3	Searching acc. index (registers nr 7664 and 7328)	4	Load next values into the buffer (registers 7672...7691 and 7344...7382)	5	Load previous values into the buffer (registers 7672...7691 and 7344...7382)	6	Go to the first memorised value in memory.	7	Go to the last memorised value in memory.
Value																							
0	Lack of operation																						
1	Searching acc. date and time (registers nr 7660...7663 and 7320...7326)																						
2	Searching acc. time (registers nr 7663 and 7326)																						
3	Searching acc. index (registers nr 7664 and 7328)																						
4	Load next values into the buffer (registers 7672...7691 and 7344...7382)																						
5	Load previous values into the buffer (registers 7672...7691 and 7344...7382)																						
6	Go to the first memorised value in memory.																						
7	Go to the last memorised value in memory.																						

7332	7666	Number of the memorised value	r	0... 750	Number of memorised value in memory, placed in the first register of the buffer	
					Value	
					0	Memory is empty
					1... 750	Number of the memorised value
7334	7667	Number of recorded registers	r	0... 750	Number of recorded buffer registers	
					Value	
					0	Buffer is empty
					1... 750	Number of recorded registers
7336	7668	Year	r	1970... 2038	Year for the value in the first register	
7338	7669	Month	r	1... 12	Month for the value in the first register	
7340	7670	Day	r	1... 31	Day for the value in the first register	
7342	7671	Time	r	0... 23.5959	Time for the value in the first register	
					This parameter occurs with four places after the decimal point in format gg.mmss, where: gg - means hours, mm - means minutes, ss - means seconds	
7344...7382	7672... 7691	Buffer	r	-	Memorised values, read off from the memory	
					20 registers , including 20 memorised values.	

1) In case of registers not occurring in the given meter series, their value

6.6. Registers only for readout

The value is placed into two successive 16-bit registers. These registers include the same data as 32-bit registers from the area 7500.		The value is placed into 32-bit registers		Name	Writing (w) Readout (r)	Unit	Quantity name
7000	7500	Identifier	r	-	Constant identifying the device		
7002	7501	Status 1	r	-	Register describing the current state of the meter		
7004	7502	Status 2	r	-	Register describing the current state of the meter		
7006	7503	Steering out	r	%	It is the register defining the control procedure of the analogue output (controllability)		
7008	7504	Min 1	r	-	Minimal value of the currently measured value		
7010	7505	Max 1	r	-	Maximal value of the currently measured value		
7012	7506	Value 1	-	-	Currently measured value		
7014	7507	Hour	-	-	Current time		
7016	7508	No occurs					
7018	7509	No occurs					
7020	7510	No occurs					

1) In case of registers no occurring in the given meter series, their values is 1E+20

Note !

- At the moment of exceeding the upper or lower range, „displayed value”, „minimum”, „maximum” parameters are set on the value 1E+20.
- For the parameter **Cnt=0** (Measurement switching off and display of the current time), „minimum”, „maximum” and „displayed value” parameters are set on the value 1E+20.

Description of the Status 1 register

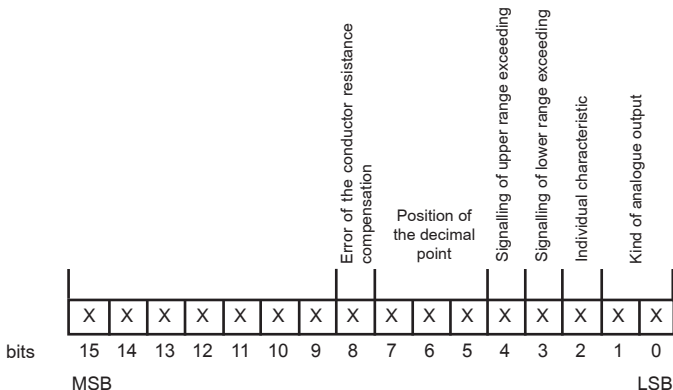

Bit-15... 9 No used

Bit-8 Error of the conductor resistance compensation

- 0 - lack of error
- 1 - signalling of the compensation error

Bit-7... 5 Position of the decimal point

- 000 - lack
- 001 - 000.0
- 010 - 00.00
- 011 - 0.000
- 100 - Auto

Bit-4 Signalling of the upper range exceeding

- 0 - normal work
- 1 - range exceeding

Bit-3 Signalling of the lower range exceeding

- 0 - normal work
- 1 - range exceeding

Bit-2 Individual characteristic

- 0 - individual characteristic switched off
- 1 - individual characteristic switched on

Bit-1...0 Kind of output (voltage, current)

- 00 - lack of analogue output
- 01 - current
- 10 - voltage

Description of the status 2 register

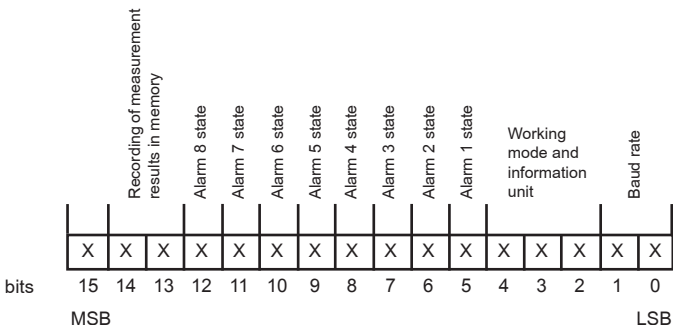

Bit-15. No used

Bit-14...13 Record of measurement results in memory

- 0 - Recording switched off
- 1 - Recording switched on

Bit-12 State of alarm 8

- 0 - off
- 1 - on

Bit-11 State of alarm 7

- 0 - off
- 1 - on

Bit-10 State of alarm 6

0 - off

1 - on

Bit-9 State of alarm 5

0 - off

1 - on

Bit-8 State of alarm 4

0 - off

1 - on

Bit-7. State of alarm 3

0 - off

1 - on

Bit-6 State of alarm 2

0 - off

1 - on

Bit-5 State of alarm 1

0 - off

1 - on

Bit-4...2 Working mode and information unit

000 - interface switched off

001 - 8N1 - ASCII

010 - 7E1 - ASCII

011 - 7O1 - ASCII

100 - 8N2 - RTU

101 - 8E1 - RTU

110 - 8O1 - RTU

111 - 8N1 - RTU

Bit-1...0 Baud rate

00 - 2400 bit/s

01 - 4800 bit/s

10 - 9600 bit/s

7. TECHNICAL DATA

INPUTS:

Pt100	(- 200... + 850)°C
Pt500	(- 200... + 850)°C
Pt1000	(- 200... + 850)°C
J (Fe-CuNi)	(- 100... + 1100)°C
K (NiCr-NiAl)	(-100... + 1370)°C
N (NiCrSi-NiSi)	(- 100... + 1300)°C
E (NiCr-CuNi)	(- 100... + 850)°C
R (PtRh13-Pt)	(0... + 1760)°C
S (PtRh10-Pt)	(0... + 1760)°C
T (Cu-CuNi)	(- 50... + 400)°C
Resistance measurement	0... 10 kΩ
Voltage measurement	± 300 mV, input resistance > 9 MΩ,
Voltage measurement	± 600 V, input resistance > 4.2 MΩ
Current measurement	± 40 mA, input resistance < 4 Ω
Current measurement	0... ± 5 A, input resistance = 10 mΩ ± 10%

Measuring subranges (preserving the class):

Pt100	320°C
Pt500	230°C
Pt1000	290°C
Thermocouple J	350°C, 700°C
Thermocouple K	450°C, 950°C
Thermocouple N	550°C, 1000°C
Thermocouple E	250°C, 520°C
Resistance	110 Ω, 220 Ω, 460 Ω, 950 Ω, 2100 Ω, 5000 Ω
Voltage	19 mV, 35 mV, 75 mV, 155 mV, 5 V, 11 V, 22 V, 45 V, 90 V, 180 V, 360 V
Current:	5 mA, 11 mA, 23 mA, 1.8 A, 3.8 A
Intensity of current flowing through the resistance thermometer:	< 400 μA
Resistance of conductors linking the resistance thermometer with the meter:	< 20 Ω/1 wire
Thermocouple characteristics acc. EN 60584-1.	
Resistance thermometer characteristics acc. IEC 751+A1+A2.	

OUTPUTS:

– **Analogue outputs** galvanically isolated, with a resolution = 0,025% of the range

- current programmable: 0/4...20 mA load resistance $\leq 500 \Omega$
- or voltage programmable: 0...10 V load resistance $\geq 500 \Omega$
- output response time 100 ms
- output error 0.2% of the range
- additional error due to ambient temperature changes: $\pm (0.1\% \text{ of the range}/10K)$

– Relay output

4 relays; voltageless make contacts - maximal load:

- voltage 250 V a.c., 150 V d.c.,
- current 5 A 30 V d.c., 250 V a.c.,
- resistance load 1250 VA, 150 W.

Programmable alarm thresholds;

Three types of alarms;

Hysteresis defined by means of the lower and upper alarm threshold;

Signalling of alarm operation on the bargraph;

– 8 outputs of open collector (OC) type

- voltageless, OC type with npn transistor (max. load 25 mA)
- range of connected voltage: 5...30 V d.c.

– Digital output:

- interface: RS-485,
- transmission protocol: MODBUS,
- ASCII: 8N1, 7E1, 7O1,
- RTU: 8N2, 8E1, 8O1, 8N1,
- baud rate: 2400, 4800, 9600 baud
- maximal response time to the request frame: 500 ms.

– **Additional supply output** 24 V d.c., maximal load 30 mA

Memory parameters:

- meter memory (recording) 750 samples
- min. record interval 1 sec;

Basic error:	0.1% of measuring range ± 1 digit
	0.2% of measuring range ± 1 digit (for thermocouples R, S, T)

Additional errors in nominal working conditions when measuring the temperature:

- compensation of reference junction temperature changes	$\pm 1^\circ\text{C}$
- compensation of conductor resistance changes	$\pm 0.1\%$ of the range
- from ambient temperature changes	$\pm (0.05\%$ of the range/10K)

Averaging time	min 200 ms
	min 500 ms (temperature ranges)

Rated operation conditions:



- supply voltage depending on the execution code	95... <u>230</u> ...253 V a.c./d.c. 20... <u>24</u> ...40 V a.c./d.c.
- supply a.c. voltage frequency	40... <u>50/60</u> ...440 Hz
- ambient temperature	- 10... <u>23</u> ...55°C
- storage temperature	- 25...+85°C
- relative humidity	< 95% (no condensation)
- pre-heating time	10 min. (for thermocouples with automatic compensation switched on: 1 hour)

Sustained overload:

- thermocouples, resistance thermometers	1 %
- measurement of voltage, current and resistance	10 %

Momentary overload (3 s):

- sensor and voltage inputs 300 mV	10 V
- voltage input > 2,5 V	$10 \times U_n$ (< 1000 V)
- current input	$10 \times I_n$



Readout field (depending on execution):	4 LED seven-segment LED display, character height: 7 mm indication range: -1999...9999 bargraph length: 88 mm - 55 segments in three-colour execution - 29 segments in seven-colour execution
Bargraph resolution	programmable
Bargraph accuracy	± 0.5 segment
Servicing	three keys:   
Ensured protection degree:	
- through the casing	IP 50
- from terminal side	IP 20
Overall dimensions	48 x 144 x 100 mm (with terminals)
Weight:	< 0.4 kg
Power consumption	< 13 VA
Resistance against supply decay:	acc. EN 61000-6-2
Electromagnetic compatibility:	
- immunity	EN 61000-6-2
- emission	EN 61000-6-4 (industrial environment)
Safety requirements according EN 61010-1:	
- installation category	III
- pollution degree	2
- phase-to-earth max. working voltage:	
- input	600 V
- supply	300 V
- relays	300 V
- analogue output	50 V
- RS-485	50 V





8. BEFORE A FAILURE WILL BE DECLARED

In case of incorrect symptoms please to acquaint with the table below.

SYMPTOMS	PROCEDURE
1. Lack of indications on the display. The bargraph indicates nothing.	Check the connection of the feeder cable.
2. The time is displayed on the display, e.g. H_12 alternately with 34:43 .	The number of measurements Cnt = 0 has been introduced. The meter is working in the SLEEP mode. It displays the current hour.
3. Marks  or  are displayed on the display.	Check the correctness of the input signal connection. See the service manual. Check also the setting of parameters D_P , Ind , LoIn and Hiln .
4. A signal inconsistent with our expectations occurs on the meter analog output.	One must check if the load resistance of the analogue output is in accordance with technical data. Check if the individual characteristic is not switched on. In case of necessity make changes of individual characteristic parameters or introduce manufacturer parameters Set .
5. Lack of possibility to enter into the programming mode. The inscription Err is displayed.	The programming mode is protected by a password. When the user forgets which password has been introduced, he should contact by phone the manufacturer or the nearest authorised workshop.
6. Lack of certainty if all segments of the display or bargraph are efficient.	Enter into the programming matrix and switch the display and bargraph tSt test on. Character fields are lighted successively from 0000 to 9999. In the same time the bargraph is lighted with successive colours. If some of segments are not lighted or diodes have different colours, one must submit these defects to the nearest workshop.
7. During the operation in the programming mode, parameter values inconsistent with the range of changes given in the table 1, appear on the display.	Enter into the programming matrix and accept the SEt parameter. The meter will introduce values in accordance with the table 2.

8. A result inconsistent with our expectations appears on the display.	Check if the individual characteristic is not switched on. In case of necessity enter into the programming matrix and accept the SEt parameter. The meter will introduce parameters in accordance with the table 2.
9. The bargraph does not work in accordance with our expectations.	Check bargraph parameters. In case of a further incorrect operation, enter into the programming matrix and accept the parameter SEt . Switch the display and bargraph tSt test on.
10. Despite the exceeding of the alarm threshold the alarm relay does not switch on.	Check the delay of alarm operation introduced into the meter. In case of need, correct the dLY parameters.
11. The meter, instead of displaying the measurement result, displays the parameter symbol and its value.	The meter is working in the preview mode or in the programming mode. Press the escape key  .
12. Despite of the introduced delay in the alarm operation, e.g. 30 seconds, the alarm after this time did not operate.	The lasting alarm state was shorter than the programmed, that means that during the lasting time, the alarm withdrawal state occurred. In such a case, the meter begins to count down the time from the beginning.
13. The meter does not establish the communication with the computer through the RS-485 interface.	Check if interface conductors (A, B, GND) were correctly connected. Then, check in the programming matrix the setting of the interface (bAud, trYb, Adr). These parameters must be the same as in the used software.

9. EXAMPLES OF NA5 METER PROGRAMMING

Example 1. Programming of the individual characteristic.

If we want to programme so that to the value 4.00 mA will correspond the value 0 on the display, whereas the value 100, to the value 20.00 mA, one must:

- enter into the programming mode and choose the **D_P** parameter responsible for the decimal point. Set the decimal point on **00000**
- choose the **Ind** parameter and switch the individual characteristic **On**
- choose the **I_H1** parameter and introduce the value 4.00
- transit on the **d_Y1** parameter and introduce the value 0
- transit on the **I_H2** parameter and introduce the value 20.00
- transit on the **d_Y2** parameter and introduce the value 100

Example 2 Programming of an inverse individual characteristic.

If we want to programme so that to the value 4.00 mA will correspond the value 120.5 on the display, and the value 10.8, to the value 20.00 mA, one must:

- enter into the programming mode and choose the **D_P** parameter responsible for the decimal point. Set the decimal point on **0000.0**
- choose the **Ind** parameter and switch the individual characteristic **On**
- choose the **I_H1** parameter and introduce the value 4.00
- transit on the **d_Y1** parameter and introduce the value 120.5
- transit on the **I_H2** parameter and introduce the value 20.00
- transit on the **d_Y2** parameter and introduce the value 10.8

Example 3 Programming of the alarm with hysteresis

If we want to programme the alarm 1 operation so that at the value 850°C, this alarm will be switched on, whereas it will be switched off at the value 100°C, and the alarm 2 operation so that at the value 1000°C this alarm will be switched off and switched on at the value -199°C, one must:

- enter into the programming mode, choose the **PrL** parameter of the alarm 1 and introduce the value 100
- transit on the **PrH** parameter of the alarm 1 and introduce the value 850
- transit on the **tYPA** parameter of the alarm 1 and choose select the function assigned as **nor**
- enter into the programming mode and choose the **PrL** parameter of the alarm 2 and introduce the value 1000
- transit on the **PrH** parameter of the alarm 2 and introduce the value -199
- transit on the **tYPA** parameter of the alarm 2 and select the function **nor**

Example 4 Programming of an alarm operating in a set interval with delay.

If we want that the alarm 1 will be switched on in the interval from 100 V to 300 V and operate only after 10 seconds, one must:

- enter into the programming mode, choose the **PrL** parameter of the alarm 1 and introduce the value 100
 - transit on the **PrH** parameter of the alarm 1 and introduce the value 300
 - transit on the **tYPA** parameter of the alarm 1 and select the function **On**
 - transit on the **dLY** parameter of the alarm 1 and introduce the value 10.0
- in case of the alarm state duration for a time longer than 10 seconds, the meter will switch the alarm relay on

Example 5 Programming of an analog output

If we want to programme so that to the displayed value 0.00 mA will correspond the value 4.00 on the analogue output, whereas to the value 20.00 mA , the value 20.00 mA, one must:

- enter into the programming mode, choose the **IndO** parameter and switch the individual characteristic **On**
- choose the **d_H1** parameter and introduce the value 0.00
- transit on the **O_Y1** parameter and introduce the value 4.00
- transit on the **d_H2** parameter and introduce the value 20.00
- transit on the **O_Y2** parameter and introduce the value 20.00

Example 6 Bargraph programming

If we want to programme so that the bargraph was of a „sector” type - red colour between PrL and PrH parameters, one must:

- enter into the programming mode , choose the **tYPb** parameter of the bargraph and choose **SEct**
- choose the **coLr** parameter of the bargraph 1 and choose **r**

Example 7 Programming a bargraph with a „magnifier”

If we want to programme so that the bargraph was blank for the value 0 and full lighted for the value 150, one must:

- enter into the programming mode , choose the **brL** parameter of the bargraph and introduce the value 0
- choose the **brH** parameter of the bargraph 1 and introduce the value 150

Example 8 Programming of recording every 20 sec from 12:30

- enter into the programming mode, choose the **Go_r** parameter and introduce the value 12:30,
- transit into **IntE** parameter and introduce the value 00:00:20,
- choose the **rEc** parameter and switch the recording in **On**,
- after exiting from the programming matrix, the memory will be erased and the meter will begin recording results evry 20 sec, from 12:30.

After filling the memory, the recordingwill be switching off.

10. ORDERING PROCEDURE

Table 5

NA5 METER WITH BARGRAPH	X	X	X	X	X	X	X	X	XX	U
Bargraph colour:										
3 colours (R, G, R + G)										T
7 colours (R, G, B, R+G, R+B, G+B, R+G+B) ...										M
Display colour:										
without display*										0
red										R
green										G
blue										B
Input signal:										
universal input (table 6)										U
on order**										X
Analogue output signal:										
without output										0
current programmed, 0/4...20 mA										1
voltage programmed, 0...10 V										2
on order**										X
Digital output signal:										
without output										0
RS-485 digital output										1
Additional outputs:										
without output										0
4 relays outputs										4
8 OC outputs										8
on order**										X
Supply:										
95...253 V a.c./d.c.										1
20... 40 V a.c./d.c.										2
on order**										X
Kind of terminals:										
socket - screw plug										0
on order***										X
Execution:										
standard										00
custom-made**										XX
Version:										
standard										U

- Notes:**
- ¹⁾ In the meter without displays, one must order the RS-485 digital output execution.
 - ²⁾ The manufacturer assigns the execution code.
 - ³⁾ Available execution with self-locking sockets.

Example of NA5 ordering:

Code: NA5 M G U 1 1 4 1 0 00 U means:

- M** - NA5 meter with two 7-colour bargraphs,
- G** - digital LED displays of green colour,
- U** - universal input (table 6),
- 1** - current analogue output signal 0/4...20 mA,
- 1** - RS-485 digital output signal,
- 4** - additional outputs consisting of 4 relays,
- 1** - supply: 95...253 V a.c./d.c.,
- 0** - socket-screw plug terminals,
- 00** - standard execution,
- U** - standard version.

In case of a custom-made execution or if you need some more additional technical information, please write to or phone our Export Department.

Input signals

Table 6

Universal input	Resistance thermometer:	
	Pt100	(- 200... +850)°C
	Pt500	(- 200... +850)°C
	Pt1000	(- 200... +850)°C
	Thermocouple:	
	J (Fe-CuNi)	(- 100... +1100)°C
	K (NiCr-NiAl)	(- 100... +1370)°C
	N (NiCrSi-NiSi)	(- 100... +1300)°C
	E (NiCr-CuNi)	(- 100... +850)°C
	R (PtRh13-Pt)	(0... +1760)°C
	S (PtRh10-Pt)	(0... +1760)°C
	T (Cu-CuNi)	(- 50... +400)°C
	Resistance	0... 10 kΩ
	Voltage	± 300 mV
Voltage	± 600 V	
current	± 40 mA	
current	± 5 A	

11. MAINTENANCE AND GUARANTEE

The NA5 meter does not require any periodical maintenance. In case of some incorrect unit operations:

1. From the shipping date, during the period given in the annexed guarantee card

One should take the meter down from the installation and return it to the Manufacturer's Quality Control Dept.

If the unit has been used in compliance with the instructions, the Manufacturer guarantees to repair it free of charge.

2. After the guarantee period:

One should turn over the meter to repair in a certified service workshop.

The disassembling of the housing causes the cancellation of the granted guarantee.

Spare parts are available for the period of five years from the date of purchase.

The Manufacturer policy is one of continuous improvement and we reserve the right to make changes in design and specification of any products as engineering advances or necessity requires and revise the above specification without notice.



Sifam Tinsley Instrumentation Inc

3105, Creekside Village Drive, Suite 801

Kennesaw GA 30144

email – psk@sifamtinsley.com

Phone - +1 404 736 4903