

# POWER QUALITY METER

WITH MODBUS RTU (RS-485) PROTOCOL

## ND31LITE



USER MANUAL



## ***Table of Content***

1 APPLICATION.....	3
2 METER SET.....	4
3 BASIC REQUIREMENTS, OPERATIONAL SAFETY.....	4
4 INSTALLATION.....	5
5 METER DESCRIPTION.....	6
5.1 Current inputs.....	6
5.2 Voltage inputs.....	7
5.3 External connection diagrams.....	7
6 ND31LITE Programming.....	12
6.1 Front panel.....	12
6.2 Starting work.....	13
6.3 Language selection.....	14
7 OPERATING MODES.....	14
7.1 Measurement mode.....	19
7.1.1 Measurement of voltage and current harmonics.....	20
7.1.2 Analog indicator.....	20
7.2 Access password.....	21
7.3 Parameters mode.....	21
7.4 Alarms mode.....	24
7.5 Display mode.....	31
7.6 Modbus mode.....	37
7.7 Settings mode.....	38
7.8 Information mode.....	38
8 SERIAL INTERFACES.....	39
8.1 RS485 INTERFACE – list of parameters.....	39
8.2 Examples of registers' readout and write.....	39
9 MAP OF ND31LITE METER REGISTERS.....	43
10 SOFTWARE UPGRADE.....	63
11 ERROR CODES.....	65
12 TECHNICAL DATA.....	66
13 ORDERING CODE.....	69

## 1 APPLICATION

The ND31LITE meter is a programmable digital instrument designed for the measurement of 1-phase 2-wire and 3-phase 3 and 4-wire power network parameters in balanced or unbalanced systems. The measured values are displayed on a 3,5" TFT full-color screen, resolution: 320 x 240 pixel. The meter enables control and optimization of the power electronic devices, systems and industrial installations.

The meter provides measurement of: RMS of voltage and current, active, reactive and apparent power, active, reactive and apparent energy, power factors, frequency, the harmonics of current and voltage /up to 63rd/, THD of voltage and current, averaged active and apparent power P Demand, S Demand, averaged current I Demand /15, 30 or 60 minutes/. Voltages and currents are multiplied by given voltage and current ratios of the measuring transformers. Power and energy indications take into account all programmed ratio values. The value of each measured value can be transmitted to the master system via the RS-485, relay outputs signal the overflow of the chosen value.

There is a galvanic separation between following units of the meter:

- supply
- voltage inputs
- current inputs
- RS485 interface

## 2 METER SET

Complete set of the meter includes:

- |                                    |       |
|------------------------------------|-------|
| 1. ND31LITE meter                  | 1 pc  |
| 2. seal                            | 1 pc  |
| 3. screw clamp to fix in the panel | 4 pcs |
| 4. plug with 16 screw terminals    | 1 pc  |
| 5. plug with 14 screw terminals    | 1 pc  |
| 6. quick start manual              | 1 pc  |



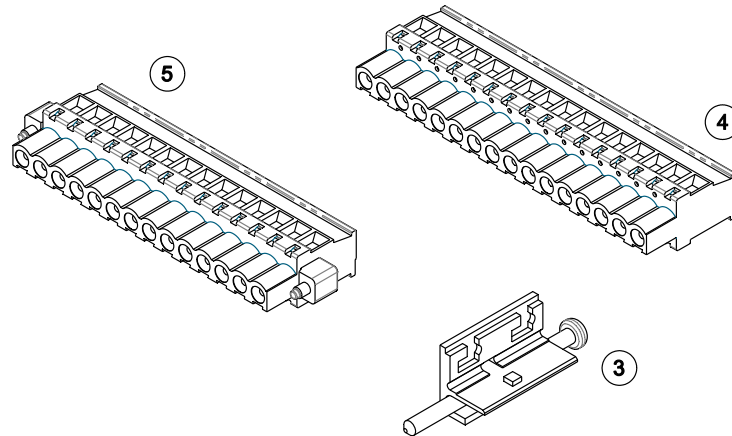

Fig. 1. Meter set

### 3 BASIC REQUIREMENTS, OPERATIONAL SAFETY

In terms of operational safety the controller meets the requirements of the EN 61010-1 (incl. changes) standard.

Remarks concerning safety:

- The meter should be installed and connected only by a qualified personnel. All relevant safety measures should be observed during installation.
- Always check the connections before turning the meter on.
- Prior to taking the meter housing off, always turn the supply off and disconnect the measuring circuits.
- Removal of the meter housing during the warranty period voids the warranty.
- This meter conforms to all requirements of the electromagnetic compatibility in the industrial environment.
- A switch or a circuit-breaker should be installed in the building or facility. It should be located near the device, easily accessible by the operator, and suitably marked.
- The meter must not be mounted within 50.8 mm (2 inches) of any electrically live parts, including primary wires, primary terminals and primary pins. This requirement does not apply to insulated cables.
- The meter attached to the housing must not come into contact with the insulation of the interior of the panel.
- Mounting brackets must not be attached to any electrically live part.
- Do not install the meter in places where the gases emitted during arc discharge from the circuit breakers can be diverted to any measuring part of the installation.
- Protection of the supply voltage path:

Protect the supply voltage with an approved (UL / IEC) fuse: ND31LITE at 85-253V AC or 90-300V DC, 1.0 A, type C;

- Protection of current measurement inputs:

The meter allows current measurement via current transformers. The circuits should then not be protected by any fuse! Never open the secondary circuit of the current transformers under load. The terminals of the secondary circuit of the current transformers must be short-circuited before dismantling the device.

- Protection of voltage measurement inputs:

In the case of direct connection and connection using transformers, the device must be protected by an approved (UL / IEC) 10 A emergency fuse or an approved (UL / IEC) 10 A miniature overcurrent circuit breaker. When using voltage transformers, their secondary terminals must never be shorted.

## 4 INSTALLATION

The meter is intended to be fixed to the panel with mounting brackets as presented on Fig. 1. The meter housing is made of a self-extinguishing plastics.

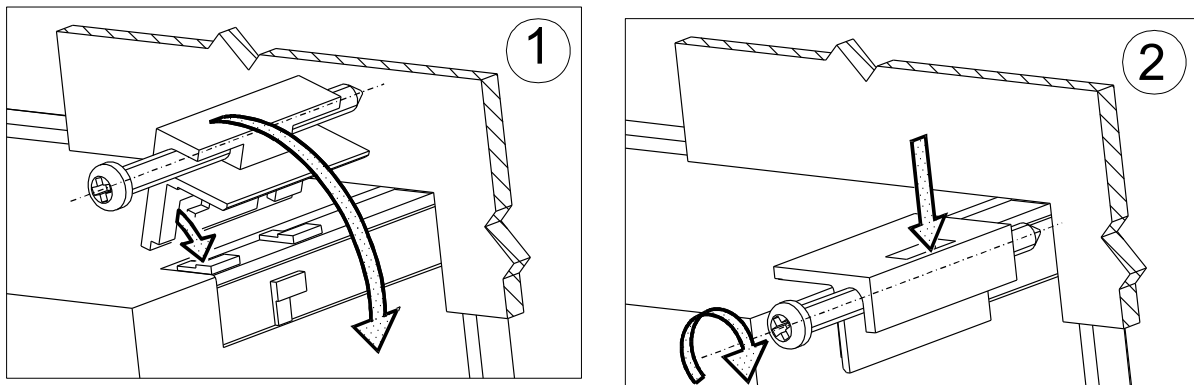

**Fig. 2. Meter fitting**

Housing overall dimensions 96 x 96 x 77 mm, dimensions of the assembly hole 92.5 x 92.5 mm. There are screw terminal strips on the outer side of the meter which enable the connection of external wires of diameter up to 2.5 mm<sup>2</sup>.

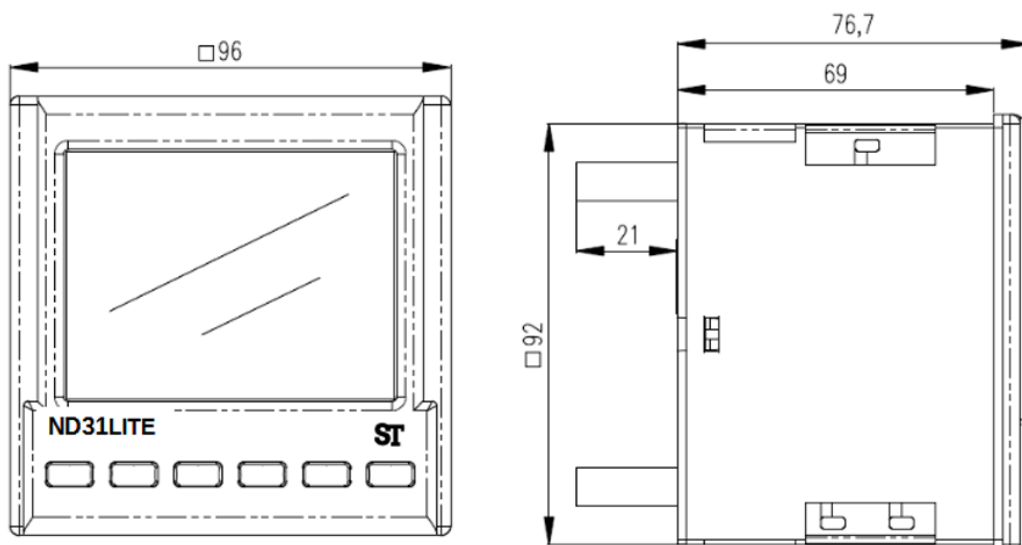

**Fig. 3. Overall dimensions of the ND31LITE meter**

## **5 METER DESCRIPTION**

### **5.1 Current inputs**

All current inputs are galvanically isolated (internal current transformers). The meter is adapted to work with external measuring current transformers / 1 A or 5 A /. Displayed current values and derivative values are automatically converted in relation to the introduced external current transformer ratio.

### **5.2 Voltage inputs**

All voltage inputs are galvanically isolated (internal transformers). Values on voltage inputs are automatically converted according to the introduced ratio of the external voltage transformer. Voltage inputs are specified in the order as 3x57.7/100 V, 3x230/400 V.

Available connection types:

- Three-phase four-wire systems with grounded/ungrounded neutral conductor with a system voltage of 3x57.7/100 V to 3x230/400V.
- Three-phase three-wire systems with grounded/ungrounded phase with a system voltage of 3x100 V to 3x400V,
- Single-phase two-wire systems 1x57.7V to 1x400V.

### **5.3 External connection diagrams**

External connections are shown in Fig. 4-7.

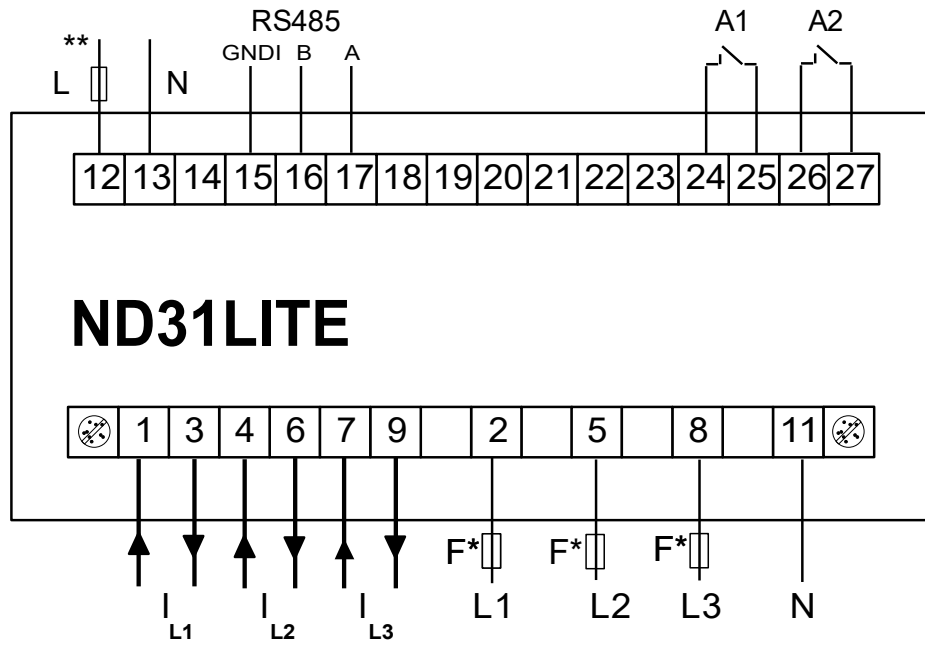

\* Fuses must be provided by the customer  
 \*\* Connection of supply voltage

**Fig. 4. Meter connections**

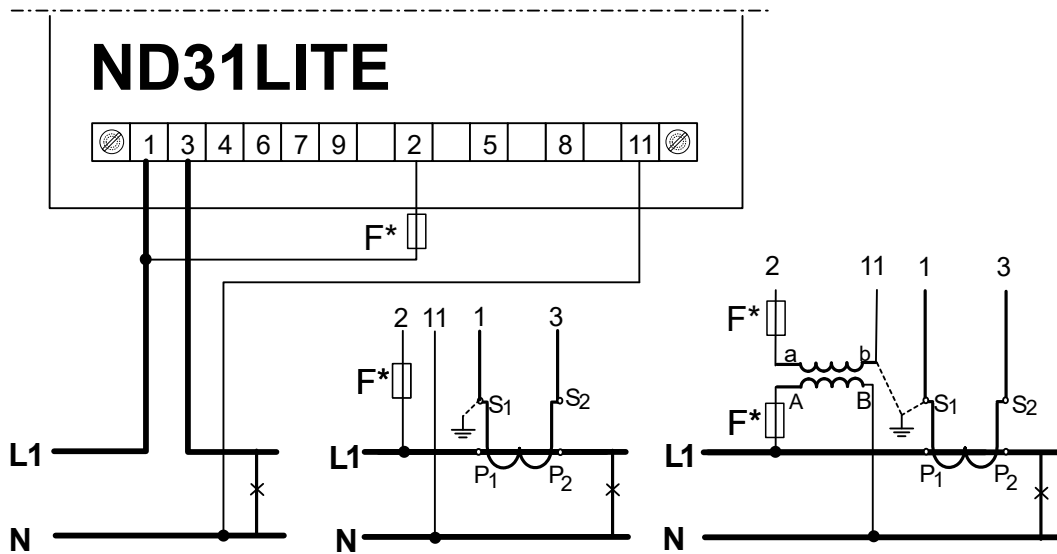

\* Fuses must be provided by the customer

**Fig. 5. Direct, semi-direct and indirect measurement in a 1-phase network**

Direct measurement in a 4-wire network

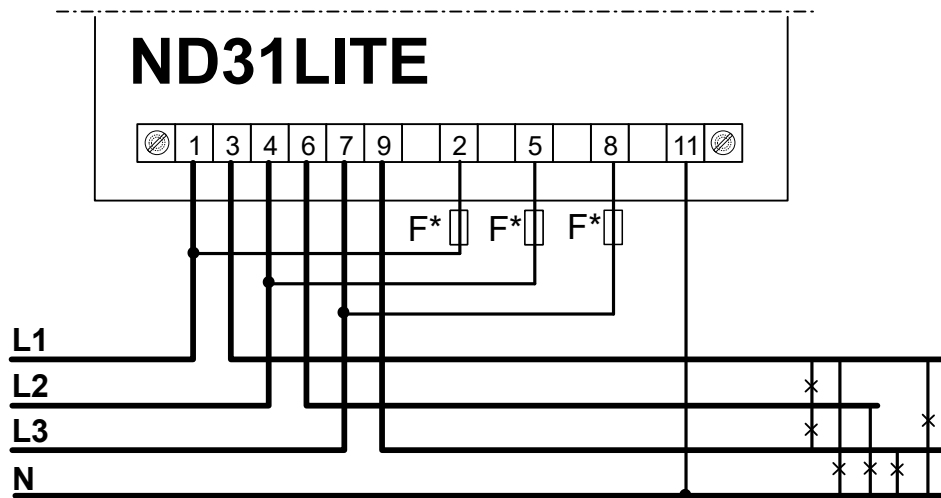

\* Fuses must be provided by the customer

Semi-direct measurement in a 4-wire network

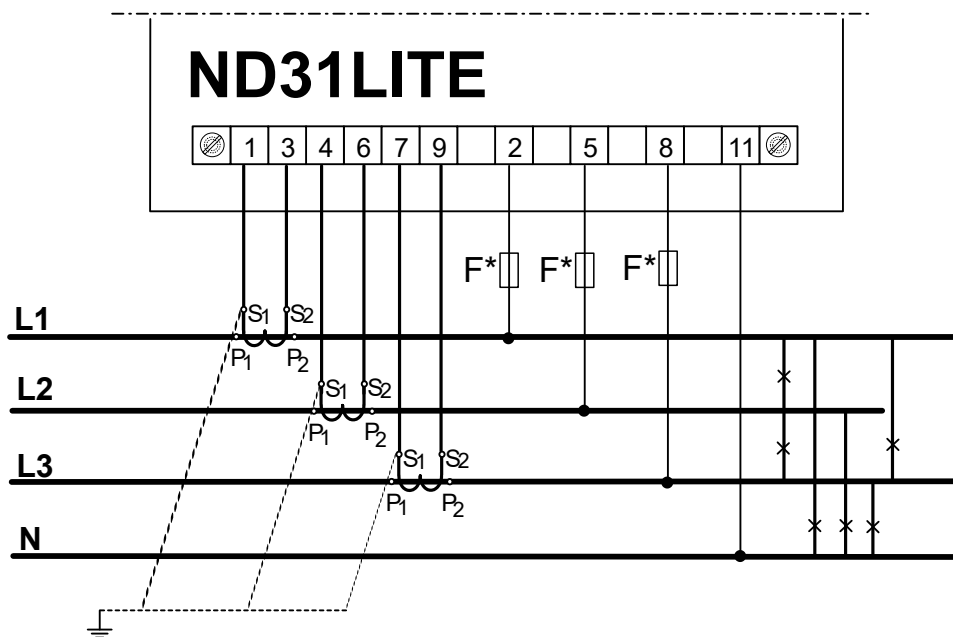

\* Fuses must be provided by the customer

Indirect measurement in a 4-wire network

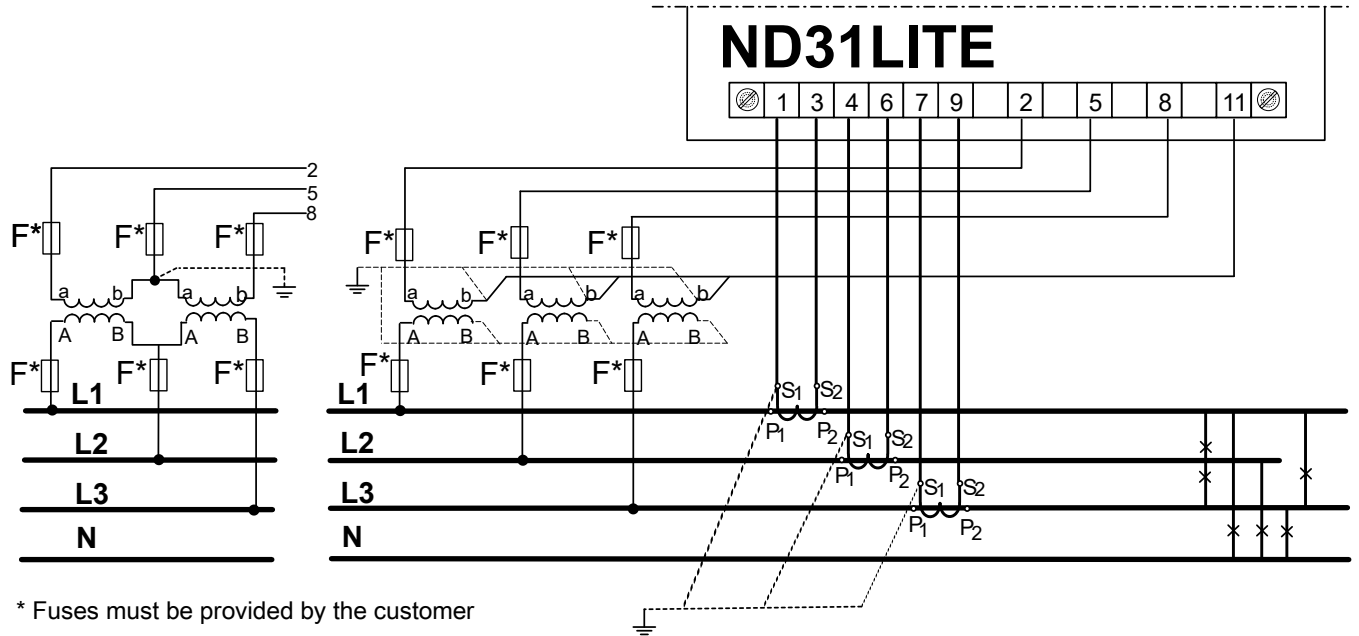
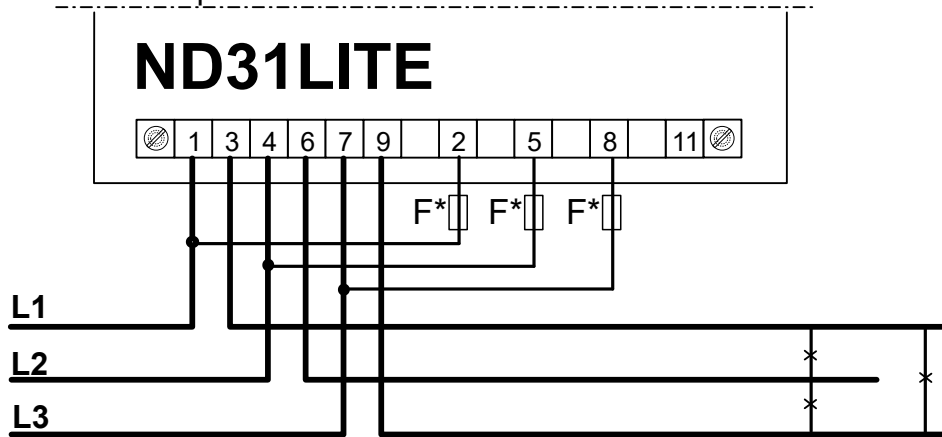

Fig.6.Connections of input signals in three-phase 4-wire network

Direct measurement in a 3-phase network



\* Fuses must be provided by the customer

Semi-direct measurement using 2 current transformers in a 3-wire network

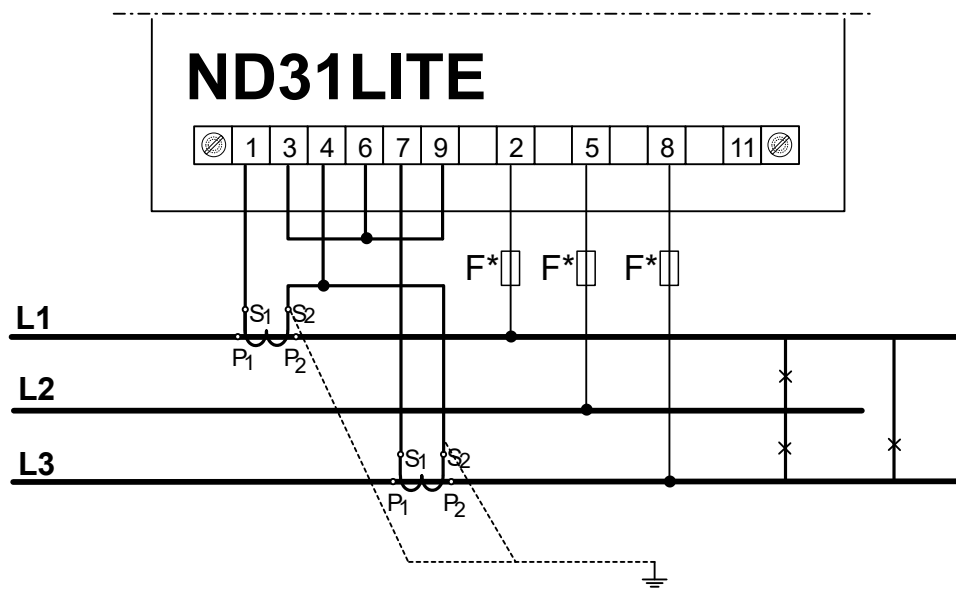

\* Fuses must be provided by the customer

Indirect measurement using 2 current transformers and 2 or 3 voltage transformers in a 3-wire network

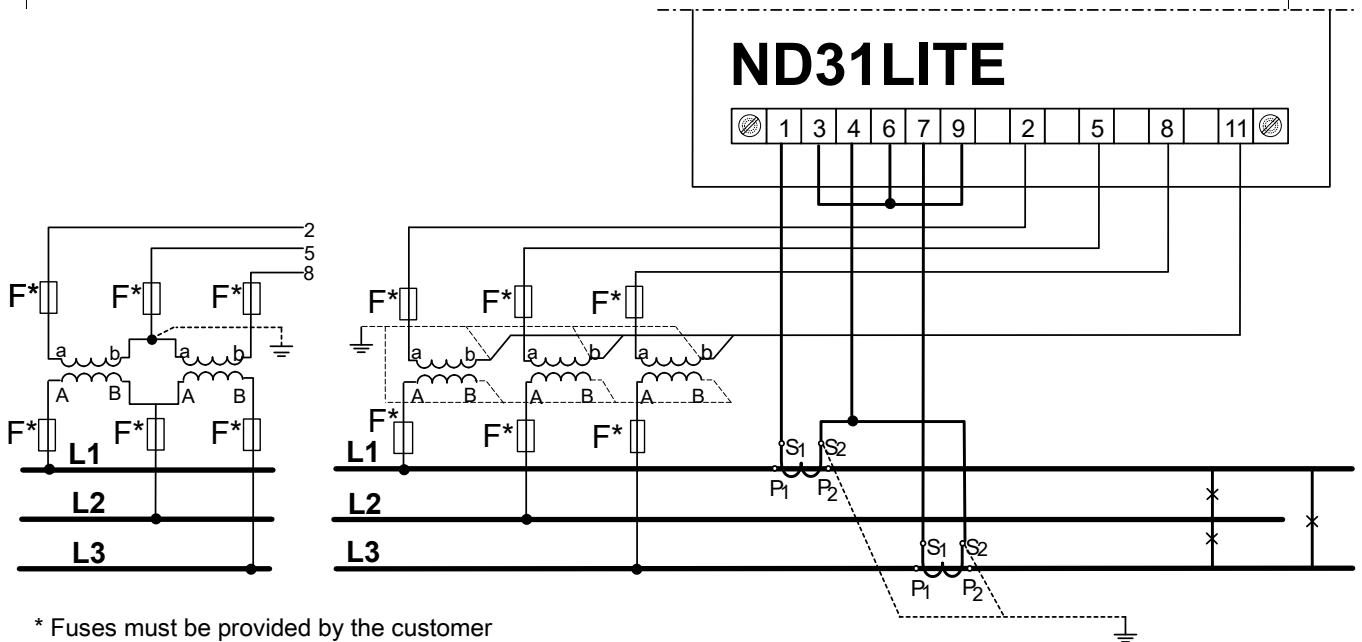

\* Fuses must be provided by the customer

**Fig 7. Connections of input signals in 3-phase 3-wire network**

## 6 ND31LITE PROGRAMMING



### 6.1 Front panel



Fig. 8. Front panel

The ND31LITE meter has 6 buttons and a full-color graphic screen. Front panel description:

f1, ... , f8	8 field displays - the digits for readout and settings,	DMD	Averaged value indicator (Demand)
V, A, W, var, VA, Wh, varh, Hz,	units of the displayed values	k, M	kilo = 10 <sup>3</sup> , Mega = 10 <sup>6</sup>
U1, I1, P1, ... ..EnQ	displayed parameters markings		The markers indicating the inductive, capacity load character

The values of the measured parameters are shown on the active pages selected by subsequent pressing the buttons  (next page) or  (previous page).

The page consists any 8 values selected from the Table 1 and displayed simultaneously on the display. The page definition is described in the **Display** mode. Depending on the location, meter buttons can perform different functions. Functions are described in the bar on the bottom of the screen. If the button lacks description, it is inactive at the moment.



Function of button 1	Function of button 2	Function of button 3	Function of button 4	Function of button 5	Function of button 6
Del		Min	Max		Menu

Fig. 9. Buttons marking – example

Information bar at the top of the screen displays the status of the alarm outputs, alarm conditions, the indicators of receiving and transmitting data on the RS485 link, date and real-time clock. A symbol "phase sequence error" will be blinking in case of a negative phase sequence.

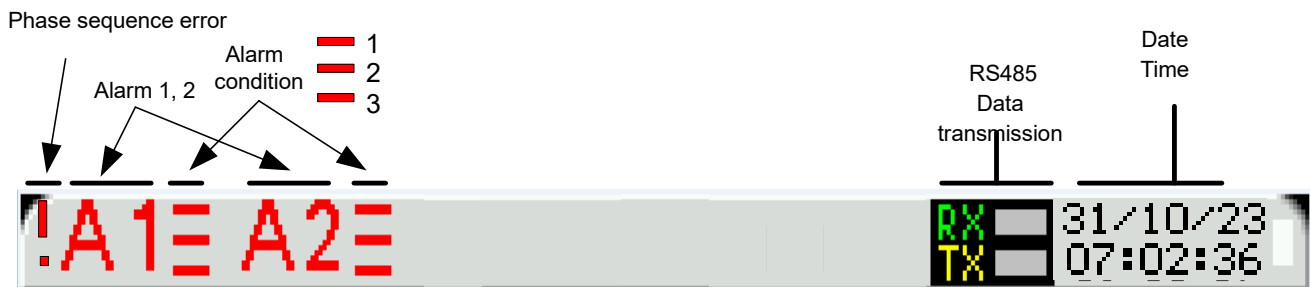

Fig. 10. Information bar

## 6.2 Starting work

After switching the supply on, the meter displays the ND31LITE meter name, version, current software version and then moves to the measurement mode and last saved page. If during the power-up the displayed screen shift to the right or left is observed, it is possible to correct this shift by setting the appropriate type of LCD display. To do this, go to the programming menu **Display** → **Settings** → **Display type** and select the correct type for which the image on the LCD screen is displayed correctly. Displayed information:

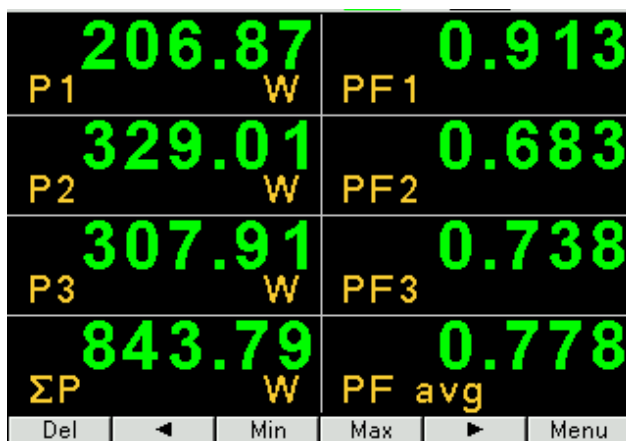
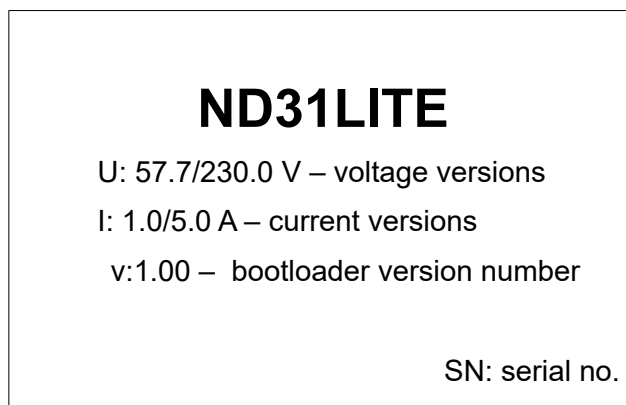



Fig. 11. Screen of meter measuring mode

## 6.3 Language selection

The preset language is English. To select a different language, press and hold the Menu button for about 10 seconds. The language selection menu will appear. The language selection is made with the  or  buttons and then confirmed again by pressing the OK button.

## 7 OPERATING MODES

The ND31LITE meter has 7 operating modes:

**Measure** – normal work mode. In the **Measure** mode the values are displayed according to the pages that are preset at the factory or configured by the user.

**Parameters** – meter parameters configuration

**Alarms** – Alarm 1, Alarm 2 configuration

**Display** – displayed pages configuration

**Modbus** – RS485 interface parameters configuration

**Settings** – settings: password, language, time, date

**Information** – preview of a program version, serial number

To move from the **Measure** mode to any other mode, press the button  for approx. 3 seconds.

Buttons   allow to select the appropriate mode, to accept press the button 

To return to a measurement mode use the button 

<b>Parameters</b>	Connection wire	Current input range	Voltage input range	Voltage transformer primary	Voltage transformer secondary	Current transformer primary	Current transformer secondary
	<input checked="" type="radio"/> 3 phase- 4 wire <input type="radio"/> 3 phase- 3 wire <input type="radio"/> 1 phase- 2 wire	<input type="radio"/> 1 A <input checked="" type="radio"/> 5 A	<input type="radio"/> 3x57.7/100 V <input checked="" type="radio"/> 3x230/400 V	<u>0000100</u>	00100. <u>0</u>	0000 <u>5</u>	0000 <u>5</u>
	Demand integ. time	AVG synchronization	Voltage connector	Voltage connector 5	Voltage connector 8	Current connector 1-3	Current connector 4-6
	<input checked="" type="radio"/> 15 min <input type="radio"/> 30 min <input type="radio"/> 60 min	<input checked="" type="radio"/> lack <input type="radio"/> with RTC	<input checked="" type="radio"/> U1 <input type="radio"/> U2 <input type="radio"/> U3	<input type="radio"/> U1 <input checked="" type="radio"/> U2 <input type="radio"/> U3	<input type="radio"/> U1 <input type="radio"/> U2 <input checked="" type="radio"/> U3	<input checked="" type="radio"/> I1 <input type="radio"/> -I1 <input type="radio"/> I2 <input type="radio"/> -I2 <input type="radio"/> I3 <input type="radio"/> -I3	<input type="radio"/> I1 <input type="radio"/> -I1 <input checked="" type="radio"/> I2 <input type="radio"/> -I2 <input type="radio"/> I3 <input type="radio"/> -I3
	Current connector 7-9	EnP energy count mode	Delete energy counters	Delete demand values	Set parameters default		
	<input type="radio"/> I1 <input type="radio"/> -I1 <input type="radio"/> I2 <input type="radio"/> -I2 <input checked="" type="radio"/> I3 <input type="radio"/> -I3	<input checked="" type="radio"/> Ferraris <input type="radio"/> Per phase	<input checked="" type="radio"/> No <input type="radio"/> active <input type="radio"/> reactive <input type="radio"/> apparent <input type="radio"/> all	<input checked="" type="radio"/> No <input type="radio"/> Yes	<input checked="" type="radio"/> No <input type="radio"/> Yes		

**Fig. 12. Programming matrix (Parameters)**

Alarms	<b>Alarms Configuration</b>		Protection Relay 1	Protection Relay 2					
			<input checked="" type="radio"/> Off <input type="radio"/> On	<input checked="" type="radio"/> Off <input type="radio"/> On					
	<b>Menu only visible when Supervisory Relay is off</b>								
	<b>Alarm 1 Alarm 2</b>		<b>Settings</b>		Logical conditions	Relay state if alarm on	Holdback alarm off	Display alarm event	Ustawienia fabryczne
					<input checked="" type="radio"/> C1 <input type="radio"/> C1 v C2 v C3 <input type="radio"/> C1 ^ C2 ^ C3 <input type="radio"/> (C1 ^ C2) v C3 <input type="radio"/> (C1 v C2) ^ C3	<input type="radio"/> Off <input checked="" type="radio"/> On	<input checked="" type="radio"/> Off <input type="radio"/> On	<input checked="" type="radio"/> Off <input type="radio"/> On	<input checked="" type="radio"/> No <input type="radio"/> Yes
	<b>Condition C1 Condition C2 Condition C3</b>		Value	Condition type	Low limit condition [%]	High limit condition [%]	Delay to condition on [s]		
			<input checked="" type="radio"/> U1 <input type="radio"/> I1 <input type="radio"/> P1 <input type="radio"/> Q1 : <input type="radio"/> hh:mm	<input checked="" type="radio"/> n_on <input type="radio"/> noFF <input type="radio"/> on <input type="radio"/> oFF <input type="radio"/> H_on : <input type="radio"/> 3_oF	+0099.0	+101.0	0000		
			Delay to condition off [s]	Holdback condition on [s]	Display condition event				
			0000	0000	<input checked="" type="radio"/> off <input type="radio"/> on				
	<b>Menu only visible when Supervisory Relay is on</b>								
<b>Alarm 1 Alarm 2 (Supervisory Relay is on)</b>		Relay State during Alarm	Active phases count	Alarm Type	Latch	Low Threshold [%]			
		<input checked="" type="radio"/> $\Omega$ wt. <input type="radio"/> Zaf.	<input type="radio"/> 1-st Phase <input type="radio"/> 2-nd Phase <input type="radio"/> 3-rd Phase <input type="radio"/> 1-2 Phases <input type="radio"/> 1-3 Phases <input type="radio"/> 2-3 Phases <input checked="" type="radio"/> All Phases	<input checked="" type="radio"/> Undervoltage <input type="radio"/> Undercurrent <input type="radio"/> Overvoltage <input type="radio"/> Overcurrent <input type="radio"/> Window (Volt.) <input type="radio"/> Window (Curr.) <input type="radio"/> Phase Failure <input type="radio"/> Assymetry (Volt.) <input type="radio"/> Assymetry (Curr.) <input type="radio"/> Phase Sequence	<input checked="" type="radio"/> off <input type="radio"/> on	095			
		High Threshold [%]	Assymetry Threshold [%]	ON State Delay [s]	OFF State Delay [s]	Alarm Hold ON Reset			
		105	03	0000	0000	<input checked="" type="radio"/> No <input type="radio"/> yes			

**Fig. 13. Programming matrix (Alarms)**

<b>Displaying</b>	<b>Settings</b>	Backlight level	Time to backlight level min [s]	Screens cfg	Pages color	LCD Display type	Set screens defaults
		<input checked="" type="radio"/> Screensaver <input type="radio"/> Minimum <input type="radio"/> Medium <input type="radio"/> Maximum	018 <u>0</u>	<input checked="" type="radio"/> Screen 1 <input checked="" type="radio"/> Screen 2 <input checked="" type="radio"/> Screen 3 : <input checked="" type="radio"/> Screen13	<input checked="" type="radio"/> green <input type="radio"/> red <input type="radio"/> yellow : <input type="radio"/> olive	<input type="radio"/> Type 1 <input checked="" type="radio"/> Type 2	<input checked="" type="radio"/> No <input type="radio"/> Yes
	<b>Screen 1</b> : <b>Screen 10</b>	Display field 1 Display field 2 : : Display field 8	Displayed value <input type="radio"/> Off <input checked="" type="radio"/> U1 <input type="radio"/> I1 <input type="radio"/> P1 <input type="radio"/> Q1 : <input type="radio"/> En S				
<b>Screen 13</b>	Displayed value	Bottom scale [%]	Upper scale [%]				
	<input type="radio"/> Off <input checked="" type="radio"/> U1 <input type="radio"/> I1 <input type="radio"/> P1 <input type="radio"/> Q1 : <input type="radio"/> T2	-0144. <u>0</u>	+0144. <u>0</u>				

**Fig. 14. Programming matrix (Displaying)**







<b>Modbus</b>	Address	Baud rate	Mode	Set Defaults 42xx registers		
	00 <u>1</u>	<input type="radio"/> 4800 b/s <input checked="" type="radio"/> 9600 b/s <input type="radio"/> 19.2 kb/s <input type="radio"/> 38.4 kb/s <input type="radio"/> 57.6 kb/s <input type="radio"/> 115.2 kb/s	<input checked="" type="radio"/> RTU 8N2 <input type="radio"/> RTU 8N1 <input type="radio"/> RTU 8O1 <input type="radio"/> RTU 8N1	<input checked="" type="radio"/> No <input type="radio"/> Yes		
<b>Settings</b>	Password	Language	Time	Date	Synchronize time now	Set defaults
	****	<input checked="" type="radio"/> English <input type="radio"/> Polski <input type="radio"/> Deutsch	13.4 <u>7</u>	09/05/202 <u>3</u>	<input checked="" type="radio"/> No <input type="radio"/> Yes	<input checked="" type="radio"/> No <input type="radio"/> Yes
<b>Information</b>	Type	Order code	Boot Version	Program Version	Serial Number	
	ND31LITE	121100	2.00	1.00	23050009	

**Fig. 15. Programming matrix (others)**

## 7.1 Measurement mode

In the **Measure** mode the values are displayed according to the pages that are preset at the factory or configured by the user in the **Display** mode.

Changing the page is done by pressing the buttons  or .

Preview of the maximum or minimum values respectively is done while the button  or  is pressed down. Reset of maximum or minimum values is done by pressing the button  while viewing their values, i.e. first the button  or  and then  must be pressed.

When reactive power or reactive inductive or capacity energy is displayed, this indication is accompanied by a symbol of the load character:  $\xi$  for an inductive load or  $\oplus$  for a capacity load.



When displaying the active power, the sign "+" is displayed for active energy import or "-" for active energy export.



Exceeding of the upper or lower indication range is signaled on the display by  $\wedge\wedge\wedge\wedge$  or  $\vee\vee\vee\vee$ . For measurement of the averaged values (P DMD, S DMD, I DMD) single measurements are carried out with 0.25 second quantum. Averaging time to choose from: 15, 30 or 60 minutes. Until all samples of the averaged values are acquired, the values are calculated from already measured samples.

Current value in the neutral wire IN is calculated from phase current vectors.

### 7.1.1 Measurement of voltage and current harmonics

The choice of harmonics is done by selecting the pages dedicated to display the values of voltage harmonics U1, U2, U3 and currents I1, I2, I3 simultaneously for 3-phase (screen 11).

The number of a displayed harmonics can be changed in the range of 2..63 by the buttons  or 

screen 12 shows a bar chart of the harmonics for each phase: voltage at the top and currents at the bottom of the screen. screen 12 shows a bar chart of the harmonics. The choice of displayed harmonics is done by pressing a button . The button  is used to select the groups of harmonics: harm<sub>2</sub> - harm<sub>26</sub>, harm<sub>27</sub> - harm<sub>52</sub> or harm<sub>2</sub> – harm<sub>51</sub>.

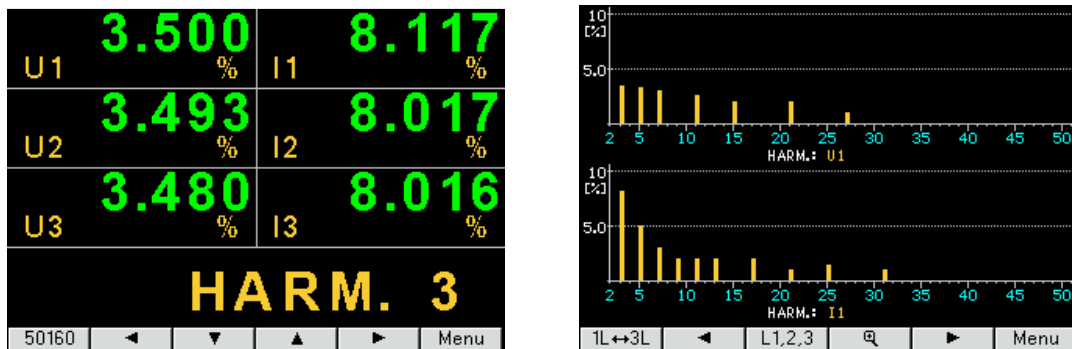







Fig. 16. Screens 11 and 12 - visualization of harmonics

### 7.1.2 Analog indicator

screen 13 shows the mapping of the selected quantity on the analog indicator. The selection of displayed quantity is made in the Display mode as described in item 7.5, by selecting screen 13.

Preview or hiding of the maximum or minimum values takes place after pressing the  or  button respectively. Deleting the maximum or minimum values is done by pressing the  and then  or  button. If the lower or upper scale threshold is exceeded, the message BOTTOM SCALE or UPPER SCALE appears.

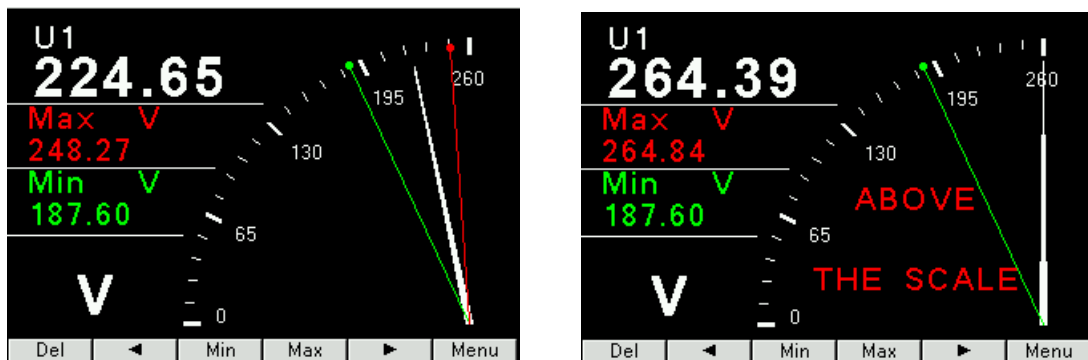

Fig.17. Screen 13 - visualization of the analog indicator

## 7.2 Access password

### The principle of access password

Access to the meter configuration is protected by a password if it is entered and is different from zero. If the password is 0000, the password question is skipped. If the password is wrong, the message "Incorrect password. Read-only menu." Then it is possible to view the meter configuration, but changes are blocked.

**Note 1:** If the user has a valid password set, and it is a password other than "0000", and the user unlocks the password, then when the power is turned off and on again, access to the configuration is again locked with the password. To erase the forgotten access password, contact the manufacturer's service department.

**Note 2:** The valid range of values for the password is "0000 ... 9999".

**Note 3:** The factory default password is "0000" and the password lock function is disabled.

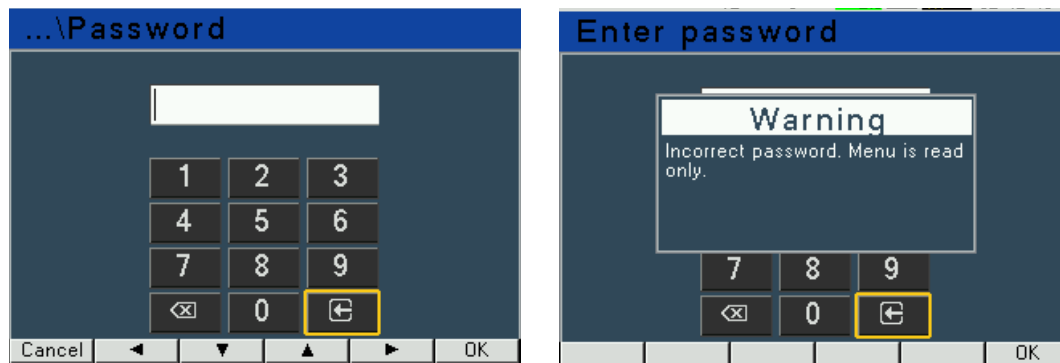

Fig. 18. Screens while entering a password

## 7.3 Parameters mode

This mode is used to determine the parameters of the meter. To enter Parameters mode press the button **Menu** for approx. 3 seconds and next using the button **▲** or **▼** select Parameters mode, to accept press the button **Select**. The parameters configuration mode is protected by a password, if it was entered and it is different from zero.

If the password is correct or it has not been entered, you can set the values according to Table 1. Buttons **▲** **▼** are used to choose the parameter, to accept press the button **Select**. Then use the buttons **▲** **▼** to choose the features of a parameter or set the requested parameter values, i.e. you can choose the digit in the decimal position by the button **◀** or **▶** the digit value by the button **▲** or **▼**. The active position is signaled by the cursor. Set value or parameter can be accepted by the button **OK** or canceled by pressing **Cancel**. Exit from the Parameters procedure follows pressing simultaneously the button **Esc** or after waiting for approx. 120 seconds. Exit from the Selecting parameters menu follows pressing the button **Exit** or after waiting for approx. 120 seconds.

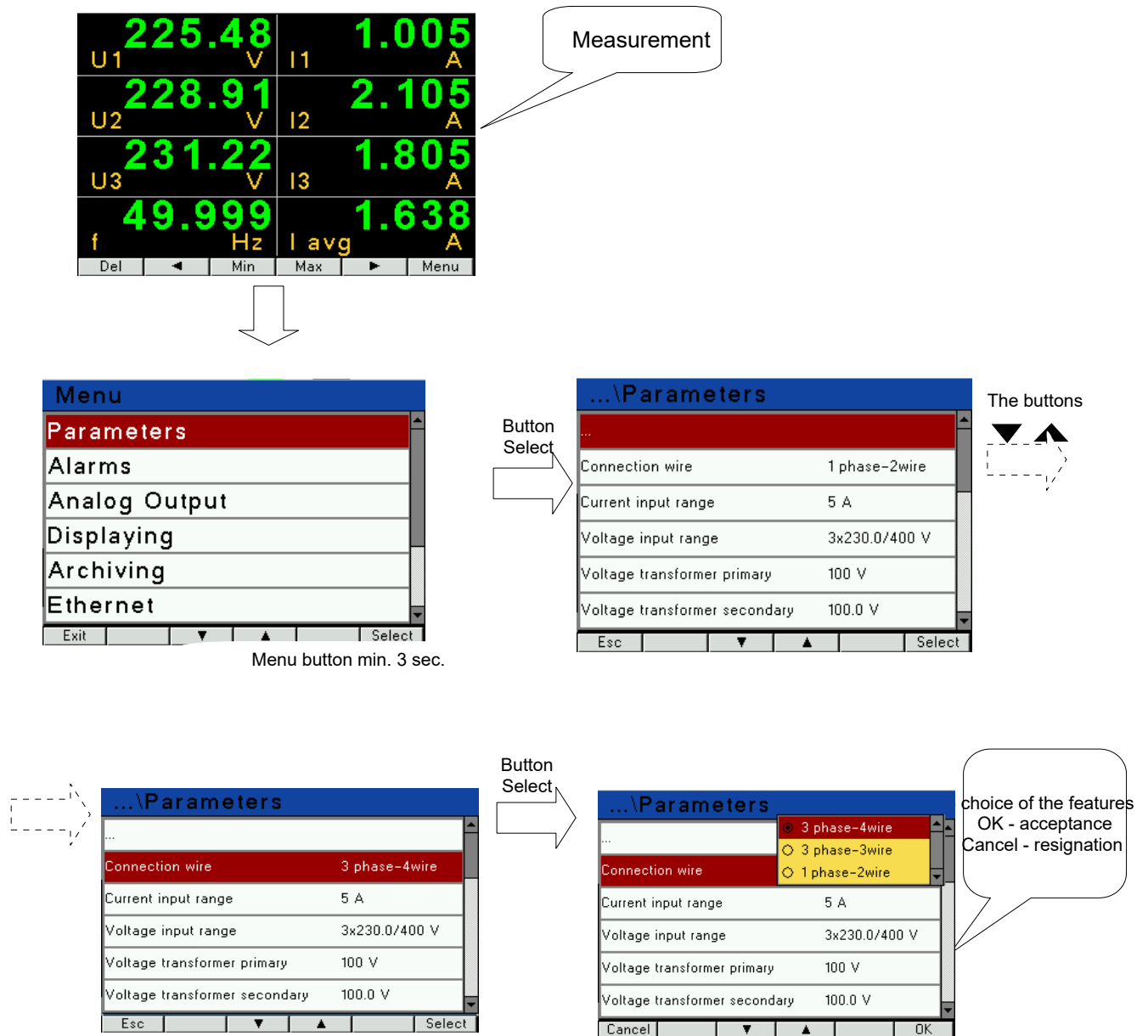

Fig. 19. Screens of Parameters mode

Table 1

Item	Parameter name	Feature / value	Description	Default settings
1	Connection wire	3 phase -4 wire 3 phase -3 wire 1 phase -2 wire	Type of power network 3-phase 4-wire 3-phase 3-wire 1-phase 2-wire	3 phase -4 wire
2	Current input range	1A, 5A	Input range: 1A or 5A	5A
3	Voltage input range	3x57.7/100 V; 3x230/400 V;	Choice of the ranges depending on the ordering code	3x230/400 V
4	Voltage transformer primary	1 .. 1245183 V		100

5	Voltage transformer secondary	0.1 .. 1000.0		100.0
6	Current transformer primary	1...20000		5
7	Current transformer secondary	1...1000		5
8	Damend integ. time	15 min, 30 min, 60 min	Averaging time active power P DMD, apparent power S DMD, current I DMD	15 min
9	AVG synchronization	none, with RTC	Averaging synchronized with the real-time clock	none
10	Voltage connector 2	U1, U2, U3		U1
11	Voltage connector 5	U1, U2, U3		U2
12	Voltage connector 8	U1, U2, U3		U3
13	Current connector 1-3	I1,-I1,I2,-I2,I3,-I3		I1
14	Current connector 4-6	I1,-I1,I2,-I2,I3,-I3		I2
15	Current connector 7-9	I1,-I1,I2,-I2,I3,-I3		I3
16	EnP energy count mode	Ferraris, Per phase	<b>Ferraris:</b> EnP+ = L1 + L2 + L3 (if sum > 0) EnP- = L1 + L2 + L3 (if sum < 0)  <b>Per phase:</b> EnP+ consumption from individual phases whose power P > 0 EnP- consumption from individual phases whose power P < 0	Ferraris
17	Delete energy counters	No, Active, Reactive, Apparent, All		No
18	Delete demand values	No, Yes		No
19	Default parameters	No, Yes		No

During changing the parameter, it is check if the value is in the range. If the set value falls outside the allowable range, the value is set to the maximum value (when entered value is too high) or minimum value (when it is too low).

**Free eCon software can also be used for configuration of the ND31LITE meters, it is available on the manufacturer's website.**

## 7.4 Alarms mode

In the options, select the **Alarms** mode and confirm selection by pressing the button **Select**.

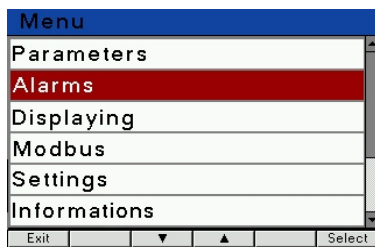

Button Select

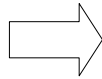

The buttons

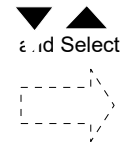

When the supervisory relay is off:

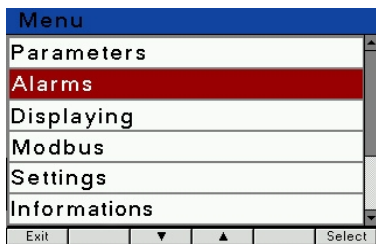

Button Select

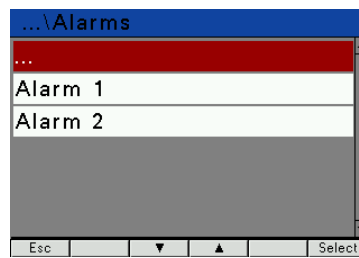
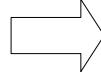

The buttons

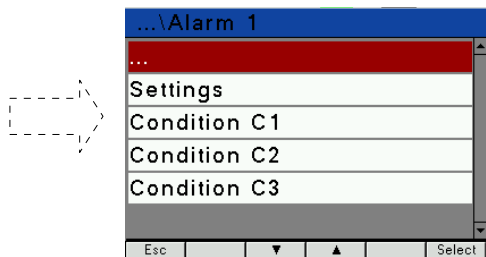
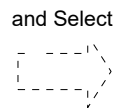

The buttons

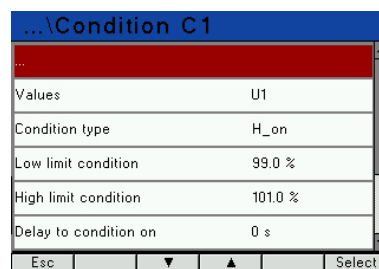
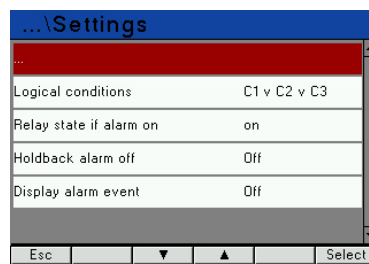

When the supervisory relay is on:

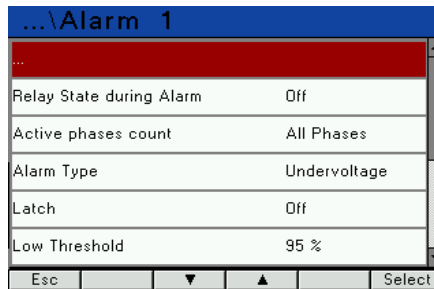

Fig. 20. Screens of Alarms mode

Table 2

Item		Parameter name	Range	Notes/description	Default settings	
	Protection Relay on	Alarm configuration	Protection Relay 1, 2	off on	off	
1		Settings	Logical conditions	C1 C1 v C2 v C3 C1 ^ C2 ^ C3 (C1 ^ C2) v C3 (C1 v C2) ^ C3	v – logic sum ^ – logic product	C1
2			Relay state if alarm on	Off/On	State of the relay at the alarm switched on Off/On	On
3			Holdback alarm off	Off/On		Off
4			Display alarm event	Off/On	When alarm indication function is enabled and the alarm state ends, alarm symbol is not turned off but begins to flash. Signalization symbol flashes until it is turned off by pressing the button <b>Del</b> and <b>Alarm</b> (> 1 sec.). This function refers only to the alarm signalization, so the relay contacts will operate without a latch according to the selected alarm type.	Off
5		Condition 1 Condition 2 Condition 3	Values	U1, I1,..., hh:mm	Value on the alarm output parameters acc. to Table 8	U1
6			Condition type	n_on, noFF, on,oFF, H_on, HoFF, 3non, 3noF, 3_on, 3_oF	Acc. to Fig.17.	n-on
7			Low limit condition	-144.0...144.0	in % of the rated input value	90.0
8			High limit condition	-144.0...144.0	in % of the rated input value	110.0
9			Delay to condition on	0 ... 3600	in seconds	0
10			Delay to condition off	0 ... 3600	in seconds	0
11			Holdback condition off->on	0 ... 3600	in seconds	0
12			Display condition event	Off/On	When a latch function is enabled and the condition state ends, condition symbol is not turned off but begins to flash. Signalization symbol flashes until it is turned off by pressing the button <b>Cancel</b> and <b>Alarm</b> (> 3 sec.).	Off
13			Relay State during Alarm	Off/On		Off
14	Active phases count		1-st Phase,2-nd Phase, 3-rd Phase,1-2 Phases, 2-3 Phases, All Phases		All Phases	

	Alarm Type	Undervoltage Undercurrent Overvoltage Overcurrent Window (Volt.) Window (Curr.) Phase Failure Assymetry (Volt.) Assymetry (Curr.) Phase Sequence	Undervoltage
15	Latch	off/on	off
16	Low Threshold	5...140	in % of the rated input value
17	High Threshold	5...140	in % of the rated input value
18	Assymetry Threshold	1...30	in % of the rated input value
19	ON State Delay [s]	0...3600	In seconds
20	OFF State Delay [s]	0...3600	In seconds
21	Alarm Hold ON Reset	No/Yes	Nie

**Operation of alarms when the supervisory relay is off.**

Entering "Upper condition value" less than "Lower condition value" disables the condition.

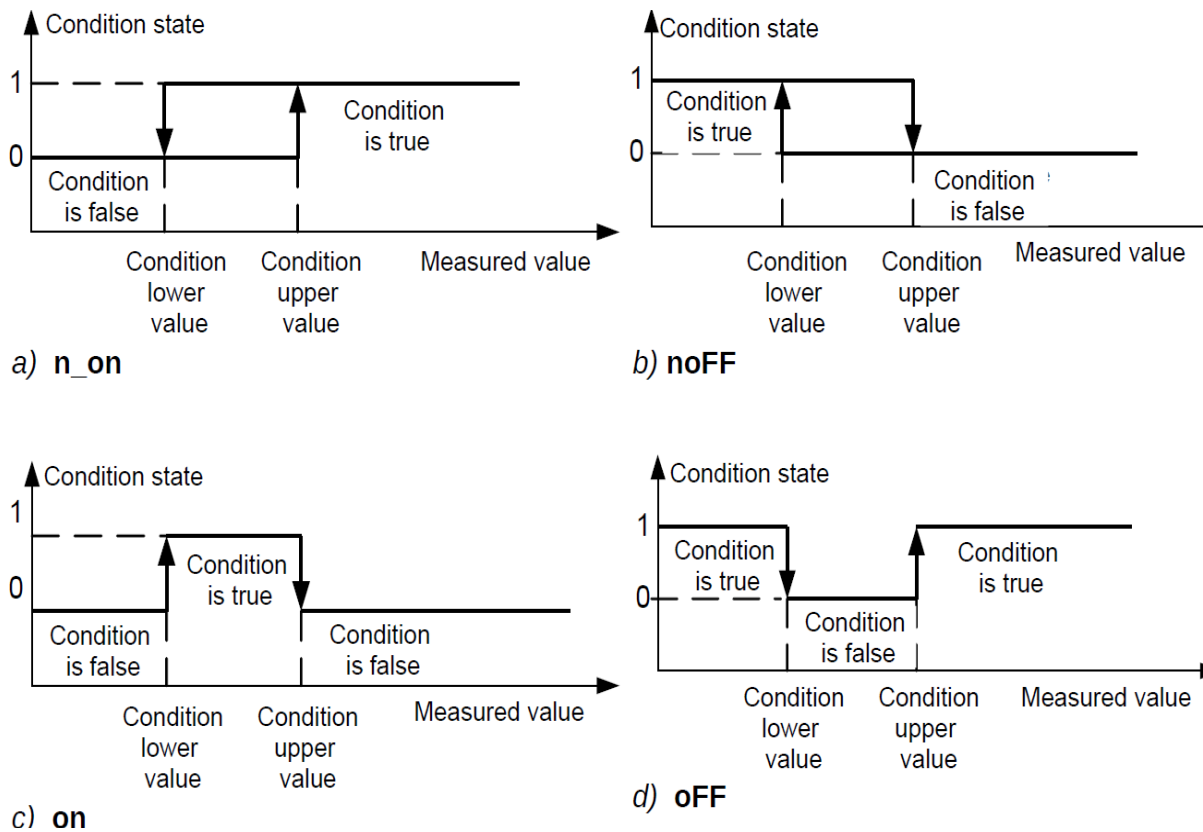

**Fig. 21. Condition types: a) n\_on b) noFF c) on d) OFF**

Remaining types of the condition:

- **H\_on** – always true;
- **HoFF** – always not true,
- **3non** – when the measuring value on any phase exceeds the "Condition upper value" - condition is true. The condition will be disabled if the measuring value on all phases will be lower than "Condition lower value".
- **3noF** – when the measuring value on any phase will be lower than the "Condition lower value" - condition is true. The condition will be disabled if the measuring value on all phases will be higher than "Condition upper value".
- **3\_on** – when the measuring value on any phase will be between the "Condition lower value" and "Condition upper value" - condition is true. The condition will be disabled if the measuring value on all phases will be below "Condition lower value" or above "Condition upper value".
- **3\_oF** – when the measuring value on any phase will be below the "Condition lower value" or above "Condition upper value" - condition is true. The condition will be disabled if the measuring value on all phases will be between the "Condition lower value" and "Condition upper value".
- The alarm value in the series 3 alarms must be in the range: 01-09, 10-18 and 19-27 (acc. to Table 8). They work with identical thresholds "Condition lower value" and "Condition upper value" for each phase. The blanking of the alarm signalization latch follows pressing the buttons **Del** and **Alarm** (> 3 sec.).

**Operation of alarms when the supervisory relay is on.**

**Alarms types: „Undervoltage”, „Undercurrent”**

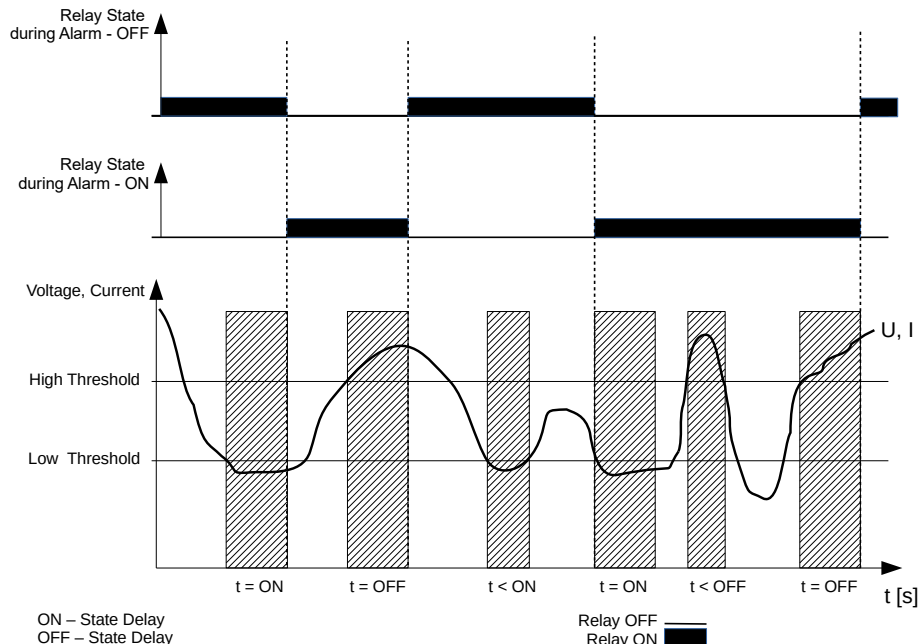

The alarm is activated when the measured value (rms. value) of the voltage or current (depends on the "Alarm type" parameter) on one, one of two or one of three phases (depends on the "Active phases count" parameter) drops below the value specified by the "Low threshold" parameter. Once the threshold is exceeded, the alarm activation delay time ("ON State Delay" parameter) starts to count down. After this time, the alarm is activated and the relay enters the state defined by the parameter "Relay State during Alarm". The alarm is deactivated when the measured value (rms value) of the voltage or current on one, two or three phases (depends on

the "Active phases count" parameter) rises above the value specified by the "High threshold" parameter. At that time, the alarm deactivation delay time (parameter "OFF State Delay") begins to count down. After this time, the alarm is switched off. If the value of any of the parameters "ON State Delay", "OFF State Delay" is equal to zero, the relay will be simultaneously activated/deactivated when the alarm is activated/deactivated.

### Alarms types: „Overvoltage”, „Overcurrent”

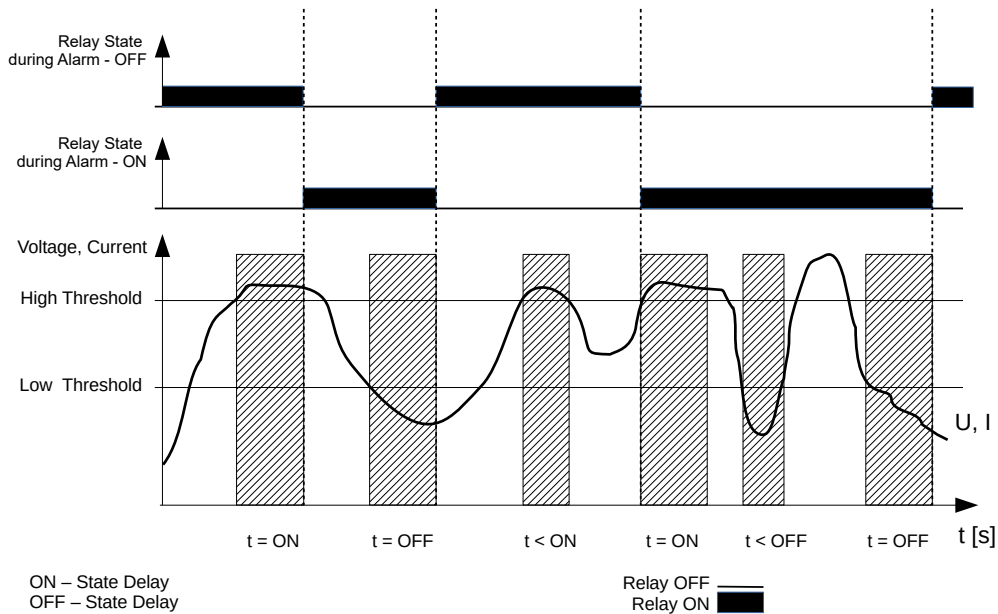

The alarm is activated when the measured value (rms value) of the voltage or current (depends on the "Alarm type" parameter) on one, one of two or one of three phases (depends on the "Active phases count" parameter) rises above the value specified by the "High threshold" parameter. Once the threshold is exceeded, the alarm activation delay time ("ON State Delay" parameter) starts counting down. After this time, the alarm is activated and the relay enters the state defined by the parameter "Relay State during Alarm". The alarm is deactivated when the measured value (rms value) of the voltage or current on one, two or three phases (depends on the "Active phases count" parameter) drops below the value specified by the "Low threshold" parameter. At that moment, the alarm deactivation delay time ("OFF State Delay" parameter) starts to count down. After this time, the alarm is deactivated. If the value of any of the parameters "ON State Delay", "OFF State Delay" is equal to zero, the transmitter will be switched on/off simultaneously when the alarm is switched on/off.

### Alarm types: „Window (Volt.)”, „Window (Curr.)”

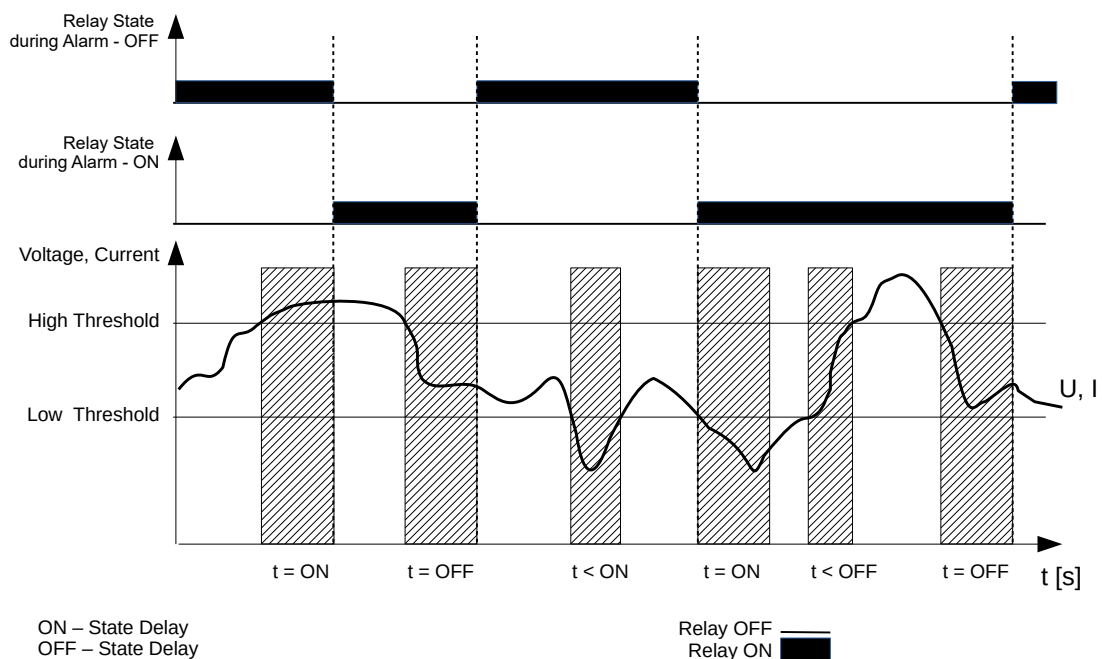

The alarm is activated when the measured value (rms value) of the voltage or current (depends on the "Alarm type" parameter) on one, one of two or one of three phases (depends on the "Active phases count" parameter) rises above the value specified by the "High threshold" parameter or falls below the value specified by the "Low threshold" parameter. When the threshold is exceeded, the alarm activation delay time ("Alarm activation delay" parameter) begins to count down. After this time, the alarm is activated and the relay enters the state specified by the parameter "Relay State during Alarm". The alarm is deactivated when the measured value (rms value) of the voltage or current on one, two or three phases (depends on the "Active phases count" parameter) falls between the values specified by the "Low threshold" and "High threshold" parameters. Then, the alarm deactivation delay time ("OFF State Delay" parameter) starts counting down. After this time, the alarm is switched off. If the value of any of the parameters "ON State Delay", "OFF State Delay" is equal to zero, the transmitter will be switched on/off simultaneously when the alarm is switched on/off.

### Alarm type: „Phase Failure”

The principle of the alarm is analogous to that of the type alarm: „**Undervoltage.**”, „**Undercurrent**”

**Alarm types: „Asymmetry (Volt.)”, „Asymmetry (Curr.)”**

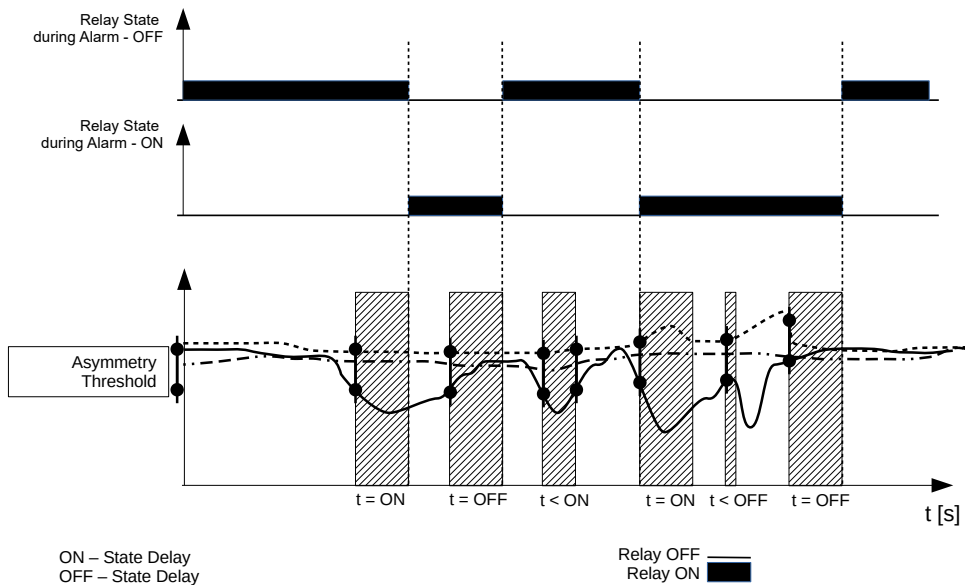

When the asymmetry for the measured values (rms values) of voltages or currents (depends on the "Alarm Type" parameter) between two phases (depends on the "Active phases count" parameter) rises above the value specified by the "Asymmetry Threshold" parameter, the countdown of the alarm activation delay time ("ON State Delay" parameter) begins. After this time, the alarm is activated and the transmitter goes into the state defined by the parameter "Relay State during Alarm". The alarm is deactivated when the asymmetry for the measured values (rms values) of voltages or currents (depends on the "Alarm type" parameter) between phases (depends on the "Active phases count" parameter) drops below the value specified by the "Asymmetry Threshold" parameter. The alarm deactivation delay time ("OFF State Delay" parameter) then starts to count down. After this time, the alarm is switched off. If the value of any of the parameters "ON State Delay", "OFF State Delay" is equal to zero, the relay will be simultaneously activated/deactivated when the alarm is activated/deactivated.

For this type of alarm, the parameter "Active phases count" must be set to two or all phases.

**Alarm type: „Phase Sequence”**

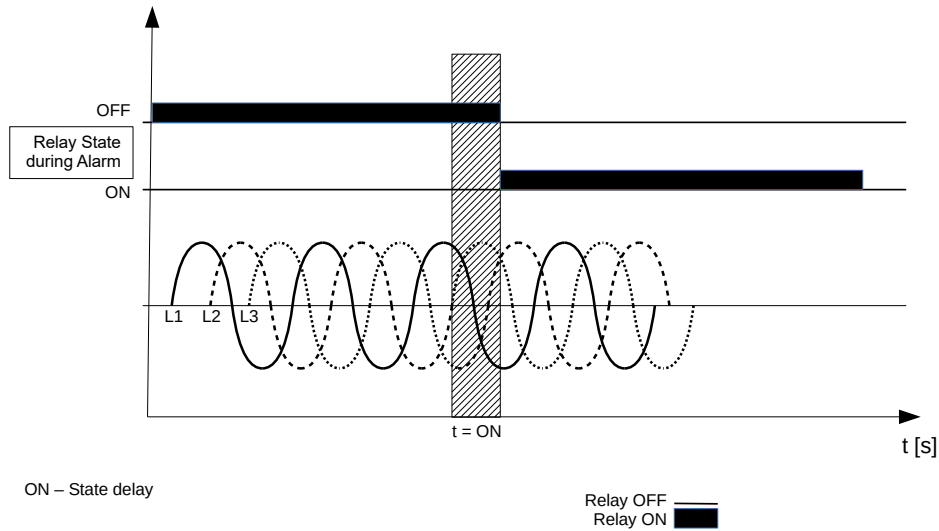

If a change in the phase sequence is detected, the alarm activation delay time ("ON State Delay" parameter) begins to count down. After this time the alarm is activated and the transmitter enters the state defined by the parameter "Relay State during Alarm". The alarm is deactivated when the phase sequence is correct. The alarm deactivation delay time starts then (parameter "OFF State Delay"). After this time, the alarm is switched off. If the value of any of the parameters "ON State Delay", "OFF State Delay" is equal to zero, the transmitter will be simultaneously activated/deactivated when the alarm is activated/deactivated. For this type of alarm, the parameter "Active phases count" must be set to two or all phases.

**7.5 Display mode**

In this mode, you can configure the screens displayed in a normal work mode of the meter  
Measurement

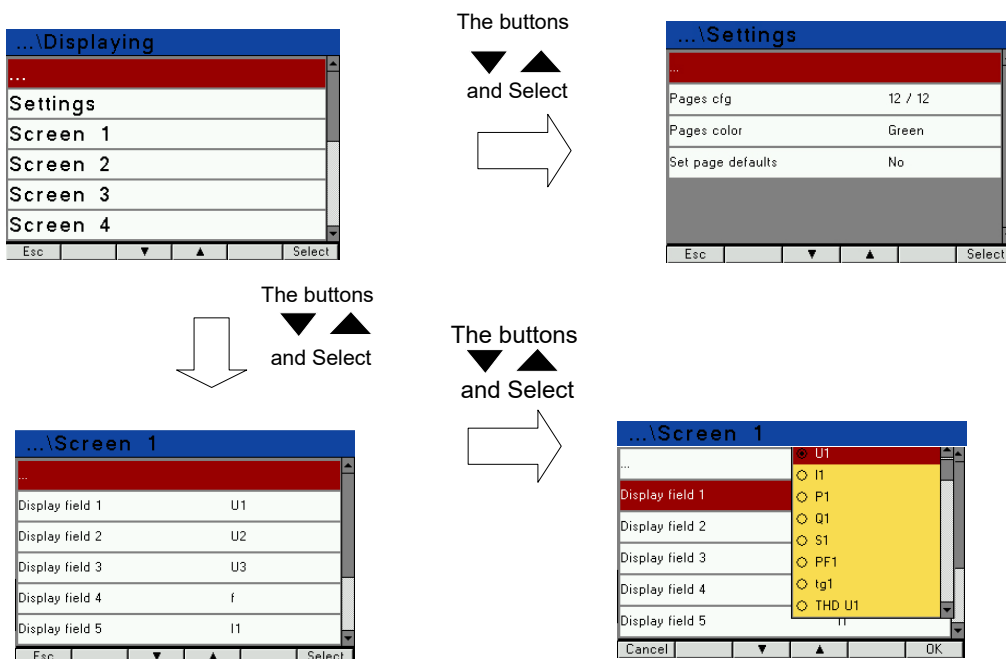

**Fig. 22. Screens of Display mode**



**Caution!**

If during the power-up the displayed screen shift to the right or left is observed, it is possible to correct this shift by setting the appropriate type of LCD display – parameter **Display type**.

Selection of displayed values:

Table 4

Item	value name	marking	unit	Signaling	3Ph / 4W	3Ph / 3W	1Ph / 2W
00	no value - blanked display field	Off			√	√	√
01	L1 phase voltage	U1	(M, k)V		√	x	√
02	L1 phase wire current	I1	(k)A		√	√	√
03	L1 phase active power	P1	(G, M, k)W		√	x	√
04	L1 phase reactive power	Q1	(G, M, k)var	ξ / ⊕	√	x	√
05	L1 phase apparent power	S1	(G, M, k)VA		√	x	√
06	L1 phase active power factor (PF1=P1/S1)	PF1			√	x	√
07	tgφ factor of L1 phase (tg1=Q1/P1)	tg1			√	x	√
08	L1 phase voltage THD*	THD U1	%		√	√	√
09	L1 phase current THD	THD I1	%		√	√	√
10	L2 phase voltage	U2	(M,k)V		√	x	x
11	L2 phase wire current	I2	(k)A		√	√	x
12	L2 phase active power	P2	(G, M, k)W		√	x	x
13	L2 phase reactive power	Q2	(G, M, k)var	ξ / ⊕	√	x	x
14	L2 phase apparent power	S2	(G, M, k)VA		√	x	x
15	L2 phase active power factor (PF2=P2/S2)	PF2	PF		√	x	x
16	tgφ factor of L2 phase (tg2=Q2/P2)	tg2			√	x	x
17	L2 phase voltage THD*	THD U2	%		√	√	x
18	L2 phase current THD	THD I2	%		√	√	x
19	L3 phase voltage	U3	(M,k)V		√	x	x
20	L3 phase wire current	I3	(k)A		√	√	x
21	L3 phase active power	P3	(G, M, k)W		√	x	x
22	L3 phase reactive power	Q3	(G, M, k)var	ξ / ⊕	√	x	x
23	L3 phase apparent power	S3	(G, M, k)VA		√	x	x
24	L3 phase active power factor (PF3=P3/S3)	PF3			√	x	x
25	tgφ factor of L3 phase (tg3=Q3/P3)	tg3			√	x	x
26	L3 phase voltage THD*	THD U3	V%		√	√	x
27	L3 phase current THD	THD I3	A%		√	√	x

28	mean phase voltage	U avg	(M, k)V		√	x	x
29	mean 3-phase current	I avg	(k)A		√	√	x
30	3-phase active power	ΣP	(G, M, k)W	+/-	√	√	√
31	3-phase reactive power	ΣQ	(G, M, k)var	ξ / ⊕	√	√	√
32	3-phase apparent power	ΣS	(G, M, k)VA		√	√	√
33	active power factor 3-phase (PF=P/S)	PF avg			√	√	x
34	tgφ factor average for 3 phases (tg=Q/P)	tg avg			√	√	x
35	THD U mean 3-phase*	THD U	%		√	√	x
36	THD I mean 3-phase	THD I	%		√	√	x
37	frequency	f	Hz		√	√	√
38	phase-to-phase voltage L1-L2	U12	(M,k)V		√	√	x
39	phase-to-phase voltage L2-L3	U23	(M,k)V		√	√	x
40	phase-to-phase voltage L3-L1	U31	(M,k)V		√	√	x
41	mean phase-to-phase voltage	U123	(M,k)V		√	√	x
42	active power averaged (P Demand)	P DMD	(G, M, k)W		√	√	√
43	apparent power averaged (S Demand)	S DMD	(G, M, k)VA		√	√	√
44	current averaged (I Demand)	I DMD	(k)A		√	√	√
45	neutral wire current	I N	(k)A		√	x	x
46							
47							
48	3-phase imported active energy **	En P+	kWh		√	√	√
49	3-phase exported active energy **	En P-	kWh		√	√	√
50	3-phase reactive inductive energy **	En Q ξ	kvarh		√	√	√
51	3-phase reactive capacitive energy**	En Q ⊕	kvarh		√	√	√
52	3-phase apparent energy**	En S	kVAh		√	√	√

\* In the 3-phase 3-wire system (3Ph / 3W) respectively THD U12, THD U23, THD U31, THD U123

\*\* The quantities can not be visualized on the analogue indicator

Default settings of the displayed screens in 3-phase 4-wire system

Table 5

P1		P2		P3		P4		P5	
U1 V	I1 A	U12 V	$\Sigma P$ W	P1 W	PF1	P1 W	Q1 var	THD U1 %	THD I1 %
U2 V	I2 A	U23 V	$\Sigma Q$ var	P2 W	PF2	P2 W	Q2 var	THD U2 %	THD I2 %
U3 V	I3 A	U31 V	$\Sigma S$ VA	P3 W	PF3	P3 W	Q3 var	THD U3 %	THD I3 %
f Hz	I avg A	U123 V	PF avg	$\Sigma P$ W	PF avg	$\Sigma P$ W	$\Sigma Q$ var	THD U %	THD I %
P6		P7		P8		P9		P10	
U1 V	S1 VA	U2 V	S2 VA	U3 V	S3 VA	$\Sigma P$ W	P DMD W	$\Sigma P$ W	+En P kWh
I1 A	PF1	I2 A	PF2	I3 A	PF3	$\Sigma Q$ var	S DMD W	$\Sigma Q$ var	-En P kWh
P1 W	tg1	P2 W	tg2	P3 W	tg3	I avg A	I DMD A	$\Sigma S$ VA	En Q $\xi$ kvarh
Q1 var	f Hz	Q2 var	f Hz	Q3 var	f Hz	I(N) A	f Hz	En S kVAh	En Q $\oplus$ kvarh
P11		P12							
U1 %	I1 %	HARM.:U1U2U3 % bargraf							
U2 %	I2 %								
U3 %	I3 %	HARM.:I1I2I3 % bargraf							
HARM.2..63									

screens 11 and 12 cannot be configured.

Default settings of the displayed screens in 3-phase 3-wire system

Table 6

P1		P2		P3		P4		P5	
U12 V	I1 A	U12 V	$\Sigma P$ W	$\Sigma P$ W	P DMD W	THD U12 %	THD I1 %	$\Sigma P$ W	En P+ kWh
U23 V	I2 A	U23 V	$\Sigma Q$ var	$\Sigma Q$ var	S DMD W	THD U23 %	THD I2 %	$\Sigma Q$ var	En P- kWh
U31 V	I3 A	U31 V	$\Sigma S$ VA	I avg A	I DMD A	THD U31 %	THD I3 %	$\Sigma S$ VA	En Q $\xi$ kvarh
f Hz	I avg A	U123 V	PF avg	tg avg	PF avg	THD U123 %	THD I %	En S kVAh	En Q $\oplus$ kvarh

Default settings of the displayed screens in 1-phase system Table 7

P1		P2		P3	
U1 V	S1 VA	P1 W	P DMD W	P1 W	En P+ kWh
I1 A	PF1	S1 VA	S DMD W	Q1 var	En P- kWh
P1 W	tg1	I1 A	I DMD A	S1 VA	En Q $\xi$ kvarh
Q1 var	f Hz	PF1	f Hz	En S kVAh	En Q $\oplus$ kvarh

Selection of the values on the alarm outputs:

Table 8

Value in registers	Displayed element	Value type	Value of the needed for calculations of percentage corresponding to 100% of the rated range.
01	U1	L1 phase voltage	$U_n$ [V] *
02	I1	L1 phase wire current	$I_n$ [A] *
03	P1	L1 phase active power	$U_n \times I_n \times \cos(0^\circ)$ [W] *
04	Q1	L1 phase reactive power	$U_n \times I_n \times \sin(90^\circ)$ [Var] *
05	S1	L1 phase apparent power	$U_n \times I_n$ [VA] *
06	PF1	L1 phase power factor (PF)	1
07	tg1	tg factor $\varphi$ of L1 phase	1
08	THD U1	L1 phase voltage THD**	100.00 [%]
09	THD I1	L1 phase current THD	100.00 [%]
10	U2	L2 phase voltage	$U_n$ [V] *
11	I2	L2 phase wire current	$I_n$ [A] *
12	P2	L2 phase active power	$U_n \times I_n \times \cos(0^\circ)$ [W] *
13	Q2	L2 phase reactive power	$U_n \times I_n \times \sin(90^\circ)$ [Var] *
14	S2	L2 phase apparent power	$U_n \times I_n$ [VA] *
15	PF2	L2 phase active power factor PF	1
16	tg2	tg $\varphi$ factor of L2 phase	1
17	THD U2	L2 phase voltage THD**	100.00 [%]
18	THD I2	L2 phase current THD	100.00 [%]
19	U3	L3 phase voltage	$U_n$ [V] *
20	I3	L3 phase wire current	$I_n$ [A] *
21	P3	L3 phase active power	$U_n \times I_n \times \cos(0^\circ)$ [W] *
22	Q3	L3 phase reactive power	$U_n \times I_n \times \sin(90^\circ)$ [Var] *
23	S3	L3 phase apparent power	$U_n \times I_n$ [VA] *
24	PF3	L3 phase active power factor PF	1
25	tg3	tg $\varphi$ factor of L3 phase	1
26	THD U3	L3 phase voltage THD**	100.00 [%]
27	THD I3	L3 phase current THD	100.00 [%]
28	U avg	mean phase voltage	0.00 [%]
29	I avg	mean 3-phase current	$I_n$ [A] *
30	$\Sigma P$	3-phase active power (P1+P2+P3)	$3 \times U_n \times I_n \times \cos(0^\circ)$ [W] *
31	$\Sigma Q$	3-phase reactive power (Q1+Q2+Q3)	$3 \times U_n \times I_n \times \sin(90^\circ)$ [Var] *
32	$\Sigma S$	3-phase apparent power (S1+S2+S3)	$3 \times U_n \times I_n$ [VA] *
33	PF avg	3-phase power factor (PF)	1
34	tg avg	tg factor $\varphi$ for 3 phases	1
35	THD U	3-phase voltage THD**	100.00 [%]
36	THD I	3-phase current THD	100.00 [%]
37	f	frequency	100 [Hz]
38	U12	phase-to-phase voltage L1-L2	$\sqrt{3} U_n$ [V] *
39	U23	phase-to-phase voltage L2-L3	$\sqrt{3} U_n$ [V] *
40	U31	phase-to-phase voltage L3-L1	$\sqrt{3} U_n$ [V] *
41	U123	mean phase-to-phase voltage	$\sqrt{3} U_n$ [V] *
42	P DMD	active power averaged (P Demand)*	$3 \times U_n \times I_n \times \cos(0^\circ)$ [W] *
43	S DMD	apparent power averaged (S Demand) *	$3 \times U_n \times I_n$ [VA] *
44	I DMD	current averaged (I Demand) *	$I_n$ [A] *
45	I N	neutral wire current	$I_n$ [A] *
46			
47			

48	En P+	Active 3-phase import energy	100,000 [kWh]
49	En P-	Active 3-phase export energy	100,000 [kWh]
50	En Q $\xi$	Reactive 3-phase inductive energy	100,000 [kvarh]
51	En Q $\oplus$	Reactive 3-phase capacity energy	100,000 [kvarh]
52	En S	3-phase apparent energy	100,000 [kVAh]
53	Phase sequence	Phase sequence	L1, L2, L3 - 0.00 [%] L1, L3, L2 - 100.00 [%]
54	hh:mm	time, hhx100+mm	2,400 - 100 [%]

\*Un, In - rated values of rated voltages and currents

\*\* In the 3-phase 3-wire (3Ph / 3W) respectively THD U12, THD U23, THD U31 THD U123

To register in each group, you can select 16 of 53 parameters (bits 1 to 53 of the registers 4106...4109 and 4115...4118). Bit set to "1" adds a parameter to a registration, set to "0" deletes. It is possible to set all 53 bits but only the first 16 bits set to "1" will be taken for a registration.

## 7.6 Modbus mode

In the options, select the **Modbus** mode and confirm your choice by pressing the button **Select**.

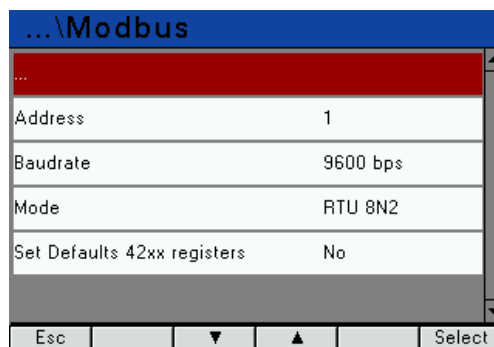

Fig.23. Screens of Modbus mode

Table 9

Item	Parameter name	Feature / value	Description	Manufacturer's value
1	Address	1...247	Modbus Network Address	1
2	Baud rate	4800 b/s, 9600 b/s, 19.2 kb/s, 38.4 kb/s, 57.7 kb/s, 115.2 kb/s	Baud rate	9600 b/s
3	Mode	RTU 8N2, RTU 8N1, RTU 8O1, RTU 8N1	Transmission mode	RTU 8N2
4	Set Defaults 42xx registers	No, Yes	Programmable group of registers for readout	No

## 7.7 Settings mode

In the options, select the **Settings** mode and confirm your choice by pressing the button **Select**.

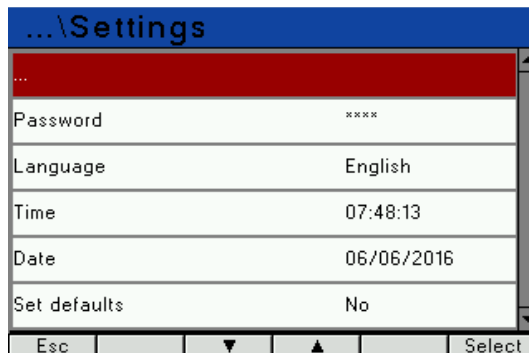

Fig.24. Screens of Settings mode

Table 10

Item	Parameter name	Feature / value	Description	Manufacturer's value
1	Password	0 .. 9999	0 - disabled	0
2	Language	English, Polski, Deutsch		English
3	Time	hh:mm	hour:minute	00:00:00
4	Date	dd/mm/yyyy	Day/month/year	1.01.2024
5	Set defaults	No, Yes		No

## 7.8 Information mode

In the options, select the **Information** mode and confirm your choice by pressing the button **Select**.

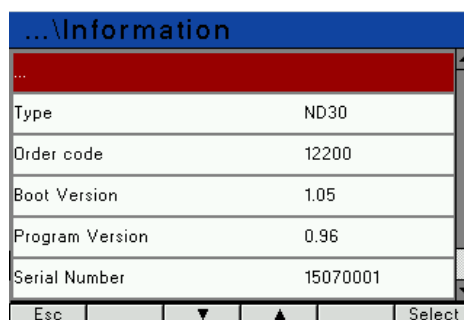

Fig.25. Screens of Information mode

Table 11

Item	Parameter name	Feature / value	Description	Manufacturer's value
1	Type		Meter type	ND31LITE
2	Order code		First 5 digits of the ordering code	e.g. 12200
3	Boot version		Bootloader version	e.g. 1.04
4	Program version		Main program version of the meter	e.g. 0.60
5	Serial number	ddmmxxxx	Current serial number of the meter day month current number	e.g. 15070006

## 8 SERIAL INTERFACES

### 8.1 RS485 INTERFACE – list of parameters

The implemented protocol is compliant with the PI-MBUS-300 Rev G specification of Modicon. List of ND31LITE meter serial interface parameters:

- identifier 0xF1
- meter address 1..247,
- baud rate 4.8, 9.6, 19.2, 38.4, 57.6, 115.2 kbit/s
- operating mode Modbus RTU
- transmission mode 8N2, 8E1, 8O1, 8N1
- max. response time 600 ms
- max. no. of registers read in a single query
  - 61 – for 4-byte registers
  - 122 – for 2-byte registers
- implemented functions
  - 03, 04, 06, 16, 17
  - 03, 04 register readout
  - 06 single register writing
  - 16 writing of n-registers,
  - 17 device identification

Default settings: address 1, baud rate 9.6 kbit/s, mode RTU 8N2

### 8.2 Examples of registers' readout and write

#### Readout of n-registers (code 03h)

**Example 1.** Readout of two 16-bit integer registers, starting with the register address 0FA0h (4000) - register values 10, 100.

Request:

Device address	Function	Register address		Number of registers		CRC checksum
		B1	B0	B1	B0	
01	03	0F	A0	00	02	C7 3D

Response:

Device address	Function	Number of bytes	Value from the register 0FA0 (4000)		Value from the register 0FA1 (4001)		CRC checksum
			B1	B0	B1	B0	
01	03	04	00	0A	00	64	E4 6F

**Example 2.** Readout of two 32-bit float registers as a combination of two 16-bit registers, starting with the register address 1B58h (7000) - register values 10, 100.

Request:

Device address	Function	Register address		Number of registers		CRC checksum
		B1	B0	B1	B0	
01	03	1B	58	00	04	C3 3E

Response:

Device address	Function	Number of bytes	Value from the register 1B58 (7000)		Value from the register 1B59 (7001)		Value from the register 1B5A (7002)		Value from the register 1B5B (7003)		CRC checksum
			B3	B2	B1	B0	B3	B2	B1	B0	
01	03	08	41	20	00	00	42	C8	00	00	E4 6F

**Example 3.** Readout of two 32-bit float registers as a combination of two 16-bit registers, starting with the register address 1770h (6000) - register values 10, 100.

Request:

Device address	Function	Register address		Number of registers		CRC checksum
		B1	B0	B1	B0	
01	03	17	70	00	04	4066

Response:

Device address	Function	Number of bytes	Value from the register 1770h (6000)		Value from the register 1770h (6000)		Value from the register 1772h (6002)		Value from the register 1772h (6002)		CRC checksum
			B1	B0	B3	B2	B1	B0	B3	B2	
01	03	08	00	00	41	20	00	00	42	C8	E4 6F

**Example 4.** Readout of two 32-bit float registers, starting with the register address 1D4Ch (7500) - register values 10, 100.

Request:

Device address	Function	Register address		Number of registers		CRC checksum
		B1	B0	B1	B0	
01	03	1D	4C	00	02	03 B0

Response:

Device address	Function	Number of bytes	Value from the register 1D4C (7500)				Value from the register 1D4D (7501)				CRC checksum
			B3	B2	B1	B0	B3	B2	B1	B0	
01	03	08	41	20	00	00	42	C8	00	00	E4 6F

### Single register writing (code 06h)

**Example 5.** Writing the value 543 (0x021F) to the register 4000 (0x0FA0)

Request:

Device address	Function	Register address		Register value		CRC checksum
		B1	B0	B1	B0	
01	06	0F	A0	02	1F	CA 54

Response:

Device address	Function	Register address		Register value		CRC checksum
		B1	B0	B1	B0	
01	06	0F	A0	02	1F	CA 54

### Writing to n-registers (code 10h)

**Example 6.** Writing two registers starting with the register address 0FA3h (4003)

Writing the values 20, 2000.

Request:

Device address	Function	Address reg.Hi	Address reg.Lo	No. of registers Hi	No. of registers Lo	Number of bytes	Value for the register 0FA3 (4003)		Value for the register 0FA4 (4004)		CRC checksum
							B1	B0	B1	B0	
01	10	0F	A3	00	02	04	00	14	07	D0	BB 9A

Response:

Device address	Function	Register address		Number of registers		CRC checksum
		B1	B0	B1	B0	
01	10	0F	A3	00	02	B2 FE

### Device identification report (code 11h)

#### Example 7. Device identification

Request:

Device address	Function	Checksum
01	11	C0 2C

Response:

Address	Function	Number of bytes	Identifier	Device status	Information field of the device software version (e.g. "ND31LITE-1.00 " - ND31LITE device with software version 1.00)	Checksum (CRC)
01	11	19	F1	FF	4E 44 33 31 4C 69 74 65 2D 31 2E 30 30 20 20 20 20 20 20 20 20 20 20	CB C2

## 9 MAP OF ND31LITE METER REGISTERS

In the ND31LITE meter, data are placed in 16 and 32-bit registers. Process variables and meter parameters are placed in the address area of registers in a way depended on the variable value type. Bits in 16-bit register are numbered from the youngest to the oldest (b0-b15). The 32-bit registers contain numbers of float type in IEEE-754 standard. 3210 byte sequence - the oldest is sent first.

Table 12

Address range	Value type	Description
4000 – 4159	Integer (16 bits)	Value set in the 16-bit register. Registers for meter configuration. Description of registers is shown in Table 16. Registers for writing and readout.
4200 – 4260	Integer (16 bits)	Value set in the 16-bit register. Registers for configuration of programmable group of registers for readout. Description of registers is shown in Table 14. Registers for writing and readout.
4300 - 4388	Integer (16 bits)	Value set in the 16-bit register. Registers for displayed screens configuration. Description of registers is shown in Table 15. Registers for writing and readout.
4400- 4485	Integer (16 bits)	Value set in the 16-bit register. Status registers, energy value, configuration data. Description of registers is shown in Table 16. Readout registers.
4600 – 4610	Integer (16 bits)	Value placed in one 16-bit register. Configuration registers of the supervisory relay.
6000 – 6970	Float (2x16 bits)	Value is set in the two following 16-bit registers. Registers contain exactly the same data, as 32-bit registers of 7500 – 7953 range. Readout registers. Bytes sequence (1-0-3-2)
7000 - 7118	Float (2x16 bits)	Content of the registers set in the registers 4200 – 4359. Bytes sequence (3-2-1-0)
7200 – 7318	Float (2x16 bits)	Content of the registers set in the registers 4200 – 4359. Bytes sequence (1-0-3-2)
7400 – 7459	Float (32 bits)	Content of the registers set in the registers 4200 – 4359. Values set in one 32-bit register.
7500 – 7985	Float (32 bits)	Values set in one 32-bit register. Description of registers is shown in Table 18. Readout registers.
8000 – 8970	Float (2x16 bits)	Value is set in the two following 16-bit registers. Registers contain exactly the same data, as 32-bit registers of 7500 – 7953 range. Readout registers. Bytes sequence (3-2-1-0)
9000 – 9144	Float (2x16 bits)	Value is set in the two following 16-bit registers Description of registers is shown in Table 19. Readout registers. Bytes sequence (1-0-3-2)
9200 – 9344	Float (2x16 bits)	Value is set in the two following 16-bit registers. Description of registers is shown in Table 19. Readout registers. Bytes sequence (3-2-1-0)

Table 13

Register address	Operations	Range	Description	Default
4000	RW	0...9999	Protection - password	0
4001	RW	0 .. 1	Type of connection 0 - 3Ph/4W 1 - 3Ph/3W 2 - 1Ph/2W	0
4002	RW	0 .. 2	Voltage on terminal 2 0 - first L1 phase voltage 1 - second L2 phase voltage 2 - third L3 phase voltage	0
4003	RW	0 .. 2	Voltage on terminal 5 0 - first L1 phase voltage	1

			1 - second L2 phase voltage 2 - third L3 phase voltage	
4004	RW	0 .. 2	Voltage on terminal 8 0 - first L1 phase voltage 1 - second L2 phase voltage 2 - third L3 phase voltage	2
4005	RW	0..5	Current on terminals 1, 3: 0 - first phase I <sub>L1</sub> current 1 - reversed direction of the current of phase L1: -I <sub>L1</sub> 2 - second phase I <sub>L2</sub> current 3 - reversed direction of the current of phase L2: -I <sub>L2</sub> 4 - third phase I <sub>L3</sub> current 5 - reversed direction of the current of phase L3: -I <sub>L3</sub>	0
4006	RW	0..5	Current on terminals 4, 6: 0 - first phase I <sub>L1</sub> current 1 - reversed direction of the current of phase L1: -I <sub>L1</sub> 2 - second phase I <sub>L2</sub> current 3 - reversed direction of the current of phase L2: -I <sub>L2</sub> 4 - third phase I <sub>L3</sub> current 5 - reversed direction of the current of phase L3: -I <sub>L3</sub>	2
4007	RW	0..5	Current on terminals 7, 9: 0 - first phase I <sub>L1</sub> current 1 - reversed direction of the current of phase L1: -I <sub>L1</sub> 2 - second phase I <sub>L2</sub> current 3 - reversed direction of the current of phase L2: -I <sub>L2</sub> 4 - third phase I <sub>L3</sub> current 5 - reversed direction of the current of phase L3: -I <sub>L3</sub>	4
4008	RW	0,1	Input current range: 1 A or 5 A: 0 - 1 A, 1 - 5 A	1
4009	RW	0,1	Input voltage range: 0 – 3 x 57.7/100 V; 1 – 3 x 230/400 V (version 1) 0 – 3 x 110/190 V; 1 – 3 x 400/690 V (version 2)	1
4010	RW	0..18	Transformer primary voltage, two older bytes	0
4011	RW	0..65535	Transformer primary voltage, two younger bytes	100
4012	RW	1 .. 10000	Transformer secondary voltage x 10	1000
4013	RW	1 .. 20000	Transformer primary current	5
4014	RW	1 .. 1000	Transformer secondary current	5
4015	RW	0...2	Averaging time of the active power P Demand apparent power S Demand current I Demand 0 – 15, 1- 30, 2- 60 minutes	0
4016	RW	0.1	Synchronization with real-time clock 0 - no synchronization 1 - synchronization with a clock	1
4017	RW		reserved	
4018	RW		reserved	
4019	RW		reserved	
4020	RW		reserved	
4021	RW		reserved	
4022	RW		reserved	
4023	RW	0..1	EnP active energy counting method 0 – Ferraris 1 – Per phase	0
4024	RW	0...4	Energy counters erasing 0 – no changes, 1 – erase active energies 2 – erase reactive energies, 3 – erase apparent energies, 4 – erase all energies	0
4025	RW	0.1	Erasing averaged parameters P Demand, S Demand, I Demand	0
4026	RW	0.1	Min, max erasing	0

4027	RW	0.1	Erasing alarm signalization latch	0
4028	RW		reserved	
4029	RW		reserved	
4030	RW	0...4	Alarm output 1 - Logic tasks of the conditions 1, 2, 3 0 – C1 1 – C1 v C2 v C3 2 – C1 ^ C2 ^ C3 3 – (C1 ^ C2) v C3 4 – (C1 v C2) ^ C3	0
4031	RW	0,1	Alarm output 1 - State of the relay at the alarm switched on: 0 - relay disabled 1 - relay enabled	1
4032	RW	0,1	Alarm output 1 - alarm deactivation lock	0
4033	RW	0,1	Alarm output 1 - alarm signalization	0
4034	RW	0.1..43	Alarm output 1 - value for the condition 1 (c1) (code as in Table 8)	38
4035	RW	0..9	Alarm output 1 - type for the condition 1: 0 – n_on, 1 – noFF, 2 – on, 3 – oFF, 4 – H_on, 5 – HoFF, 6 – 3non, 7 – 3noF, 8 – 3_on, 9 – 3_oF	0
4036	RW	-1440..0..1440 [%oo]	Alarm output 1 - lower value of the condition 1 switch of the rated input range	900
4037	RW	-1440..0..1440 [%oo]	Alarm output 1 - upper value of the condition 1 switch of the rated input range	1100
4038	RW	0..3600 s	Alarm output 1 - condition 1 activation delay	0
4039	RW	0..3600 s	Alarm output 1 - condition 1 deactivation delay	0
4040	RW	0..3600 s	Alarm output 1 - condition 1 re-activation lock	0
4041	RW	0,1	Alarm output 1 - condition 1 signalization	0
4042	RW		reserved	
4043	RW	0.1..54	Alarm output 1 - value for the condition 2 (c2) (code as in Table 8)	38
4044	RW	0..9	Alarm output 1 - type for the condition 2: 0 – n_on, 1 – noFF, 2 – on, 3 – oFF, 4 – H_on, 5 – HoFF, 6 – 3non, 7 – 3noF, 8 – 3_on, 9 – 3_oF	0
4045	RW	-1440..0..1440 [%oo]	Alarm output 1 - lower value of the condition 2 switch of the rated input range	900
4046	RW	-1440..0..1440 [%oo]	Alarm output 1 - upper value of the condition 2 switch of the rated input range	1100
4047	RW	0..3600 s	Alarm output 1 - condition 2 activation delay	0
4048	RW	0..3600 s	Alarm output 1 - condition 2 deactivation delay	0
4049	RW	0..3600 s	Alarm output 1 - condition 2 re-activation lock	0
4050	RW	0,1	Alarm output 1 – condition 2 signalization	0
4051	RW		reserved	
4052	RW	0.1..54	Alarm output 1 - value for the condition 3 (c3) (code as in Table 8)	38
4053	RW	0..9	Alarm output 1 - type for the condition 3: 0 – n_on, 1 – noFF, 2 – on, 3 – oFF, 4 – H_on, 5 – HoFF, 6 – 3non, 7 – 3noF, 8 – 3_on, 9 – 3_oF	0
4054	RW	-1440..0..1440 [%oo]	Alarm output 1 - lower value of the condition 3 switch of the rated input range	900
4055	RW	-1440..0..1440 [%oo]	Alarm output 1 - upper value of the condition 3 switch of the rated input range	1100
4056	RW	0..3600 s	Alarm output 1 - condition 3 activation delay	0
4057	RW	0..3600 s	Alarm output 1 - condition 3 deactivation delay	0
4058	RW	0..3600 s	Alarm output 1 - condition 2 re-activation lock	0
4059	RW	0,1	Alarm output 1 – condition 2 signalization	0

4060	RW		reserved	
4061	RW	0...4	Alarm output 2 - Logic tasks of the conditions 1, 2, 3 0 – C1 1 – C1 ∨ C2 ∨ C3 2 – C1 ∧ C2 ∧ C3 3 – (C1 ∧ C2) ∨ C3 4 – (C1 ∨ C2) ∧ C3	0
4062	RW	0,1	Alarm output 2 - State of the relay at the alarm switched on: 0 - relay disabled 1 - relay enabled	1
4063	RW	0,1	Alarm output 2 - alarm deactivation lock	0
4064	RW	0,1	Alarm output 2 - alarm signalization	0
4065	RW	0.1..54	Alarm output 2 - value for the condition 1 (c1) (code as in Table 8)	38
4066	RW	0..9	Alarm output 2 - type for the condition 1: 0 – n_on, 1 – noFF, 2 – on, 3 – oFF, 4 – H_on, 5 – HoFF, 6 – 3non, 7 – 3noF, 8 – 3_on, 9 – 3_oF	0
4067	RW	-1440..0..1440 [‰]	Alarm output 2 - lower value of the condition 1 switch of the rated input range	900
4068	RW	-1440..0..1440 [‰]	Alarm output 2 - upper value of the condition 1 switch of the rated input range	1100
4069	RW	0..3600 s	Alarm output 2 - condition 1 activation delay	0
4070	RW	0..3600 s	Alarm output 2 - condition 1 deactivation delay	0
4071	RW	0..3600 s	Alarm output 2 - condition 1 re-activation lock	0
4072	RW	0,1	Alarm output 2– condition 1 signalization	0
4073	RW		reserved	
4074	RW	0.1..54	Alarm output 2 - value for the condition 2 (c2) (code as in Table 8)	38
4075	RW	0..9	Alarm output 2 - type for the condition 2: 0 – n_on, 1 – noFF, 2 – on, 3 – oFF, 4 – H_on, 5 – HoFF, 6 – 3non, 7 – 3noF, 8 – 3_on, 9 – 3_oF	0
4076	RW	-1440..0..1440 [‰]	Alarm output 2 - lower value of the condition 2 switch of the rated input range	900
4077	RW	-1440..0..1440 [‰]	Alarm output 2 - upper value of the condition 2 switch of the rated input range	1100
4078	RW	0..3600 s	Alarm output 2 - condition 2 activation delay	0
4079	RW	0..3600 s	Alarm output 2 - condition 2 deactivation delay	0
4080	RW	0..3600 s	Alarm output 2 - condition 2 re-activation lock	0
4081	RW	0,1	Alarm output 2– condition 2 signalization	0
4082	RW		reserved	
4083	RW	0.1..54	Alarm output 2 - value for the condition 3 (c3) (code as in Table 8)	38
4084	RW	0..9	Alarm output 2 - type for the condition 3: 0 – n_on, 1 – noFF, 2 – on, 3 – oFF, 4 – H_on, 5 – HoFF, 6 – 3non, 7 – 3noF, 8 – 3_on, 9 – 3_oF	0
4085	RW	-1440..0..1440 [‰]	Alarm output 2 - lower value of the condition 3 switch of the rated input range	900
4086	RW	-1440..0..1440 [‰]	Alarm output 2 - upper value of the condition 3 switch of the rated input range	1100
4087	RW	0..3600 s	Alarm output 2 - condition 3 activation delay	0
4088	RW	0..3600 s	Alarm output 2 - condition 3 deactivation delay	0
4089	RW	0..3600 s	Alarm output 2 - condition 2 re-activation lock	0
4090	RW	0,1	Alarm output 2 - condition 2 signalization	0
4091	RW		reserved	
4092	RW		reserved	
4093	RW		reserved	

4094	RW		reserved	
4095	RW		reserved	
4096	RW		reserved	
4097	RW		reserved	
4098	RW		reserved	
4099	RW		reserved	
4100	RW	1..247	Modbus Network Address	1
4101	RW	0..3	Transmission mode: 0->8n2, 1->8e1, 2->8o1, 3->8n1	0
4102	RW	0..5	Baud rate: 0->4800, 1->9600 2->19200, 3->38400, 4->57600, 5->115200	1
4103	RW		reserved	
4104	RW	0.1	Upgrade change of transmission parameters	0
4105	RW		reserved	
4106	RW		reserved	
4107	RW		reserved	
4108	RW		reserved	
4109	RW		reserved	
4110	RW		reserved	
4111	RW		reserved	
4112	RW		reserved	
4113	RW		reserved	
4114	RW		reserved	
4115	RW		reserved	
4116	RW		reserved	
4117	RW		reserved	
4118	RW		reserved	
4119	RW		reserved	
4120	RW		reserved	
4121	RW		reserved	
4122	RW		reserved	
4123	RW		reserved	
4124	RW		reserved	
4125	RW		reserved	
4126	RW		reserved	
4127	RW		reserved	
4128	RW		reserved	
4129	RW		reserved	
4130	RW		reserved	
4131	RW		reserved	
4132	RW		reserved	
4133	RW		reserved	
4134	RW		reserved	
4135	RW		reserved	
4136	RW		reserved	
4137	RW		reserved	
4138	RW		reserved	
4139	RW		reserved	
4140	RW		reserved	
4141	RW		reserved	
4142	RW		reserved	
4143	RW		reserved	
4144	RW		reserved	
4145	RW		reserved	
4146	RW		reserved	
4147	RW		reserved	
4148	RW		reserved	
4149	RW		reserved	

4150	RW	0..2	Menu language: 0-ENG, 1-PL, 2-DE	0
4151	RW	0.1	reserved	0
4152	RW	0.1	Saving default parameters (complete with resetting energy as well as min, max and mean power to 0) and Ethernet,	0
4153	RW	0..59	Seconds	0
4154	RW	0...2359	Hour *100 + minutes	0
4155	RW	101...1231	Month * 100 + day	101
4156	RW	2015...2077	Year	2015
4157	RW		reserved	
4158	RW		reserved	
4159	RW		reserved	

The alarm switching values stored in the registers 4036, 4037, 4054, 4055, 4067, 4068, 4076, 4077, 4085, 4086 are multiplied by 10, e.g. the value of 100% should be entered as "1000".

Table 14

Register address	Operations	Range	Description	Default
4200	RW	7500 .. 7957	Register 1 of programmable group of registers for readout	7500
4201	RW	7500 .. 7957	Register 2 of programmable group of registers for readout	7501
4202	RW	7500 .. 7957	Register 3 of programmable group of registers for readout	7502
4203	RW	7500 .. 7957	Register 4 of programmable group of registers for readout	7503
4204	RW	7500 .. 7957	Register 5 of programmable group of registers for readout	7504
4205	RW	7500 .. 7957	Register 6 of programmable group of registers for readout	7505
4206	RW	7500 .. 7957	Register 7 of programmable group of registers for readout	7506
4207	RW	7500 .. 7957	Register 8 of programmable group of registers for readout	7507
4208	RW	7500 .. 7957	Register 9 of programmable group of registers for readout	7508
4209	RW	7500 .. 7957	Register 10 of programmable group of registers for readout	7509
4210	RW	7500 .. 7957	Register 11 of programmable group of registers for readout	7510
4211	RW	7500 .. 7957	Register 12 of programmable group of registers for readout	7511
4212	RW	7500 .. 7957	Register 13 of programmable group of registers for readout	7512
4213	RW	7500 .. 7957	Register 14 of programmable group of registers for readout	7513
4214	RW	7500 .. 7957	Register 15 of programmable group of registers for readout	7514
4215	RW	7500 .. 7957	Register 16 of programmable group of registers for readout	7515
4216	RW	7500 .. 7957	Register 17 of programmable group of registers for readout	7516
4217	RW	7500 .. 7957	Register 18 of programmable group of registers for readout	7517
4218	RW	7500 .. 7957	Register 19 of programmable group of registers for readout	7518
4219	RW	7500 .. 7957	Register 20 of programmable group of registers for readout	7519
4220	RW	7500 .. 7957	Register 21 of programmable group of registers for readout	7520
4221	RW	7500 .. 7957	Register 22 of programmable group of registers for readout	7521
4222	RW	7500 .. 7957	Register 23 of programmable group of registers for readout	7522
4223	RW	7500 .. 7957	Register 24 of programmable group of registers for readout	7523
4224	RW	7500 .. 7957	Register 25 of programmable group of registers for readout	7524
4225	RW	7500 .. 7957	Register 26 of programmable group of registers for readout	7525
4226	RW	7500 .. 7957	Register 27 of programmable group of registers for readout	7526
4227	RW	7500 .. 7957	Register 28 of programmable group of registers for readout	7527
4228	RW	7500 .. 7957	Register 29 of programmable group of registers for readout	7528
4229	RW	7500 .. 7957	Register 30 of programmable group of registers for readout	7529
4230	RW	7500 .. 7957	Register 31 of programmable group of registers for readout	7530
4231	RW	7500 .. 7957	Register 32 of programmable group of registers for readout	7531
4232	RW	7500 .. 7957	Register 33 of programmable group of registers for readout	7532
4233	RW	7500 .. 7957	Register 34 of programmable group of registers for readout	7533
4234	RW	7500 .. 7957	Register 35 of programmable group of registers for readout	7534
4235	RW	7500 .. 7957	Register 36 of programmable group of registers for readout	7535
4236	RW	7500 .. 7957	Register 37 of programmable group of registers for readout	7536
4237	RW	7500 .. 7957	Register 38 of programmable group of registers for readout	7537

Register address	Operations	Range	Description	Default
4238	RW	7500 .. 7957	Register 39 of programmable group of registers for readout	7538
4239	RW	7500 .. 7957	Register 40 of programmable group of registers for readout	7539
4240	RW	7500 .. 7957	Register 41 of programmable group of registers for readout	7540
4241	RW	7500 .. 7957	Register 42 of programmable group of registers for readout	7541
4242	RW	7500 .. 7957	Register 43 of programmable group of registers for readout	7542
4243	RW	7500 .. 7957	Register 44 of programmable group of registers for readout	7543
4244	RW	7500 .. 7957	Register 45 of programmable group of registers for readout	7544
4245	RW	7500 .. 7957	Register 46 of programmable group of registers for readout	7545
4246	RW	7500 .. 7957	Register 47 of programmable group of registers for readout	7546
4247	RW	7500 .. 7957	Register 48 of programmable group of registers for readout	7547
4248	RW	7500 .. 7957	Register 49 of programmable group of registers for readout	7548
4249	RW	7500 .. 7957	Register 50 of programmable group of registers for readout	7549
4250	RW	7500 .. 7957	Register 51 of programmable group of registers for readout	7550
4251	RW	7500 .. 7957	Register 52 of programmable group of registers for readout	7551
4252	RW	7500 .. 7957	Register 53 of programmable group of registers for readout	7552
4253	RW	7500 .. 7957	Register 54 of programmable group of registers for readout	7553
4254	RW	7500 .. 7957	Register 55 of programmable group of registers for readout	7554
4255	RW	7500 .. 7957	Register 56 of programmable group of registers for readout	7559
4256	RW	7500 .. 7957	Register 57 of programmable group of registers for readout	7560
4257	RW	7500 .. 7957	Register 58 of programmable group of registers for readout	7561
4258	RW	7500 .. 7957	Register 59 of programmable group of registers for readout	7566
4259	RW	7500 .. 7957	Register 60 of programmable group of registers for readout	7567
4260	RW	0,1	Restore default group 0 – no changes, 1 – restore default group	0

Table 15

Register address	Operations	Range	Description	Default
4300	RW	0...3	Luminosity level: 0 – Screensaver, 1 – Minimum, 2 – Medium, 3 - Maximum	0
4301	RW	0 .. 3600	Time to min. luminosity	180
4302	RW	0..7	Screen colour	0
4303	RW	0x0001...0x1FFF	Enabling screen display Bit0 – screen 1, Bit1 – screen 2, ...Bit12 – screen 13	0x1FFF
4304	RW		reserved	
4305	RW	00..52	Screen 1 display 1, U1	1
4306	RW	00..52	Screen 1 display 2, U2	10
4307	RW	00..52	Screen 1 display 3, U3	19
4308	RW	00..52	Screen 1 display 4, f	37
4309	RW	00..52	Screen 1 display 5, I1	2
4310	RW	00..52	Screen 1 display 6, I2	11
4311	RW	00..52	Screen 1 display 7, I3	20
4312	RW	00..52	Screen 1 display 8, I avg	28
4313	RW	00..52	Screen 2 display 1, U12	38
4314	RW	00..52	Screen 2 display 2, U23	39
4315	RW	00..52	Screen 2 display 3, U31	40
4316	RW	00..52	Screen 2 display 4, U123	41
4317	RW	00..52	Screen 2 display 5, ΣP	30
4318	RW	00..52	Screen 2 display 6, ΣQ	31
4319	RW	00..52	Screen 2 display 7, ΣS	32
4320	RW	00..52	Screen 2 display 8, PF avg	33

Register address	Operations	Range	Description	Default
4321	RW	00..52	Screen 3 display 1, P1	3
4322	RW	00..52	Screen 3 display 2, P2	12
4323	RW	00..52	Screen 3 display 3, P3	21
4324	RW	00..52	Screen 3 display 4, $\Sigma$ P	30
4325	RW	00..52	Screen 3 display 5, PF1	6
4326	RW	00..52	Screen 3 display 6, PF2	15
4327	RW	00..52	Screen 3 display 7, PF3	24
4328	RW	00..52	Screen 3 display 8, PF avg	33
4329	RW	00..52	Screen 4 display 1, P1	3
4330	RW	00..52	Screen 4 display 2, P2	12
4331	RW	00..52	Screen 4 display 3, P3	21
4332	RW	00..52	Screen 4 display 4, $\Sigma$ P	30
4333	RW	00..52	Screen 4 display 5, Q1	4
4334	RW	00..52	Screen 4 display 6, Q2	13
4335	RW	00..52	Screen 4 display 7, Q3	22
4336	RW	00..52	Screen 4 display 8, $\Sigma$ Q	31
4337	RW	00..52	Screen 5 display 1, THD U1	8
4338	RW	00..52	Screen 5 display 2, THD U2	17
4339	RW	00..52	Screen 5 display 3, THD U3	26
4340	RW	00..52	Screen 5 display 4, THD U	35
4341	RW	00..52	Screen 5 display 5, THD I1	9
4342	RW	00..52	Screen 5 display 6, THD I2	18
4343	RW	00..52	Screen 5 display 7, THD I3	27
4344	RW	00..52	Screen 5 display 8, THD I	36
4345	RW	00..52	Screen 6 display 1, U1	1
4346	RW	00..52	Screen 6 display 2, I1	2
4347	RW	00..52	Screen 6 display 3, P1	3
4348	RW	00..52	Screen 6 display 4, Q1	4
4349	RW	00..52	Screen 6 display 5, S1	5
4350	RW	00..52	Screen 6 display 6, PF1	6
4351	RW	00..52	Screen 6 display 7, tg1	7
4352	RW	00..52	Screen 6 display 8, f	37
4353	RW	00..52	Screen 7 display 1, U2	10
4354	RW	00..52	Screen 7 display 2, I2	11
4355	RW	00..52	Screen 7 display 3, P2	12
4356	RW	00..52	Screen 7 display 4, Q2	13
4357	RW	00..52	Screen 7 display 5, S2	14
4358	RW	00..52	Screen 7 display 6, PF2	15
4359	RW	00..52	Screen 7 display 7, tg2	16
4360	RW	00..52	Screen 7 display 8, f	37
4361	RW	00..52	Screen 8 display 1, U3	19
4362	RW	00..52	Screen 8 display 2, I3	20
4363	RW	00..52	Screen 8 display 3, P3	21
4364	RW	00..52	Screen 8 display 4, Q3	22
4365	RW	00..52	Screen 8 display 5, S3	23
4366	RW	00..52	Screen 8 display 6, PF3	24
4367	RW	00..52	Screen 8 display 7, tg3	25
4368	RW	00..52	Screen 8 display 8, f	37
4369	RW	00..52	Screen 9 display 1, $\Sigma$ P	30
4370	RW	00..52	Screen 9 display 2, $\Sigma$ Q	31
4371	RW	00..52	Screen 9 display 3, I avg	29
4372	RW	00..52	Screen 9 display 4, I(N)	45
4373	RW	00..52	Screen 9 display 5, P DMD	42
4374	RW	00..52	Screen 9 display 6, S DMD	43

Register address	Operations	Range	Description	Default
4375	RW	00..52	Screen 9 display 7, I DMD	44
4376	RW	00..52	Screen 9 display 8, f	37
4377	RW	00..52	Screen 10 display 1, $\Sigma P$	30
4378	RW	00..52	Screen 10 display 2, $\Sigma Q$	31
4379	RW	00..52	Screen 10 display 3, $\Sigma S$	32
4380	RW	00..52	Screen 10 display 4, En S	52
4381	RW	00..52	Screen 10 display 5, +En P	48
4382	RW	00..52	Screen 10 display 6, -En P	49
4383	RW	00..52	Screen 10 display 7, $\xi$ En Q	50
4384	RW	00..52	Screen 10 display 8, $\oplus$ En Q	51
4385	RW	0..3	Restore manufacturer's Screens 0 - no , 1 – 3Ph/4W , 2 - 3Ph/3W 3 - 1PH/2W	0
4386	RW	00..47	Quantity displayed on the analog indicator: 0-Off, 1-U1, 2-I1, ...46-I(N)	1
4387	RW	-1440 .. 1440	Bottom scale	0
4388	RW	-1440 .. 1440	Upper scale	1000

Table 16

Register address	Operations	Range	Description	Default
4400	R		reserved	
4401	R	0..65535	Identifier	D9
4402	R	0..65535	Bootloader version x 100	-
4403	R	0..65535	Program version x100	-
4404	R		reserved	
4405	R	0..65535	Ordering codes	-
4406	R	0..65535	Nominal voltage x10	577/2300
4407	R	0..65535	Nominal voltage x10	1100/4000
4408	R	0..65535	Nominal current (1 A) x 100	100
4409	R	0..65535	Nominal current (5 A) x 100	500
4410	R		reserved	
4411	R	0..65535	Seventh and sixth byte (B7.B6) of a serial number, format B7:B6:B5:B4:B3:B2:B1:B0	-
4412	R	0..65535	Fifth and fourth byte (B5.B4) of a serial number, format B7:B6:B5:B4:B3:B2:B1:B0	-
4413	R	0..65535	Third and second byte (B3.B2) of a serial number, format B7:B6:B5:B4:B3:B2:B1:B0	-
4414	R	0..65535	First and zero byte (B1.B0) of a serial number, format B7:B6:B5:B4:B3:B2:B1:B0	-
4415	R	0..65535	Status 1 Register – see description below	0
4416	R	0..65535	Status 2 Register – see description below	0
4417	R	0..65535	Status 3 Register – see description below	0
4418	R	0..65535	Status 4 Register – see description below	0
4419	R	0..65535	Status 5 Register – see description below	0
4420	R	0..65535	Status 6 Register – see description below	0
4421	R		reserved	

4422	R		reserved	
4423	R		reserved	
4424	R		reserved	0
4425	R		reserved	0
4426	R	0..152	Active import energy, two older bytes	0
4427	R	0..65535	Active import energy, two younger bytes	0
4428	R	0..152	Active export energy, two older bytes	0
4429	R	0..65535	Active export energy, two younger bytes	0
4430	R	0..152	Reactive inductive energy, two older bytes	0
4431	R	0..65535	Reactive inductive energy, two younger bytes	0
4432	R	0..152	Reactive capacity energy, two older bytes	0
4433	R	0..65535	Reactive capacity energy, two younger bytes	0
4434	R	0..152	Apparent energy, two older bytes	0
4435	R	0..65535	Apparent energy , two younger bytes	0
4436	R		reserved	
4437	R		reserved	
4438	R		reserved	
4439	R		reserved	
4440	R		reserved	
4441	R		reserved	
4442	R		reserved	
4443	R		reserved	
4444	R		reserved	
4445	R		reserved	
4446	R		reserved	
4447	R		reserved	
...				
4461	R		reserved	
4462	R	0..152	Active imported 3-phase energy for the previous year, two older bytes	0
4463	R	0..65535	Active imported 3-phase energy for the previous year, two younger bytes	0
4464	R	0..152	Active exported 3-phase energy for the previous year, two older bytes	0
4465	R	0..65535	Active exported 3-phase energy for the previous year, two younger bytes	0
4466	R	0..152	Active imported 3-phase energy for the current year, two older bytes	0
4467	R	0..65535	Active imported 3-phase energy for the current year, two younger bytes	0
4468	R	0..152	Active exported 3-phase energy for the current year, two older bytes	0
4469	R	0..65535	Active exported 3-phase energy for the current year, two younger bytes	0
4470	R	0..152	Active imported 3-phase energy for the current month, two older bytes	0
4471	R	0..65535	Active imported 3-phase energy for the current month, two younger bytes	0
4472	R	0..152	Active exported 3-phase energy for the current month, two older bytes	0
4473	R	0..65535	Active exported 3-phase energy for the current month, two younger bytes	0
4474	R	0..152	Active imported 3-phase energy for the current week, two older bytes	0
4475	R	0..65535	Active imported 3-phase energy for the current week, two younger bytes	0
4476	R	0..152	Active exported 3-phase energy for the current week, two older bytes	0
4477	R	0..65535	Active exported 3-phase energy for the current week,	0

			two younger bytes	
4478	R	0..152	Active imported 3-phase energy for the current 48 hours, two older bytes	0
4479	R	0..65535	Active imported 3-phase energy for the current 48 hours, two younger bytes	0
4480	R	0..152	Active exported 3-phase energy for the current 48 hours, two older bytes	0
4481	R	0..65535	Active exported 3-phase energy for the current 48 hours, two younger bytes	0
4482	R	0..152	Active imported 3-phase energy for the current 24 hours, two older bytes	0
4483	R	0..65535	Active imported 3-phase energy for the current 24 hours, two younger bytes	0
4484	R	0..152	Active exported 3-phase energy for the current 24 hours, two older bytes	0
4485	R	0..65535	Active exported 3-phase energy for the current 24 hours, two younger bytes	0

Energiy is made available in hundreds of watt-hours (Var-hours) in double 16-bit registers, so when converting the values of individual energies from the registers, it is necessary to divide them by 100 i.e:

Active energy consumed = (reg. value 4426 x 65536 + reg. value 4427) / 100 [kWh].

Active energy given up = (value of rej.4428 x 65536 + value of rej. 4429) / 100 [kWh].

Inductive reactive energy = (rej.4430 value x 65536 + rej.4431 value) / 100 [kVarh].

Capacitive reactive energy = (rej.4432 value x 65536 + rej.4433 value) / 100 [kVarh]

Apparent energy = (rej.4434 value x 65536 + rej.4435 value) / 100 [kVAh],

Similarly, recalculate the energies from registers 4462 to 4485

### Status 1 Register of a device (address 4415, R):

Bit 15 – "1" – FRAM memory damage	Bit 7 – "1" – phase sequence error
Bit 14 – "1" – no calibration of the input	Bit 6 – "1" – reserved
Bit 13 – "1" – no calibration of the output	Bit 5 – "1" – error in the supervisory relay registers
Bit 12 – "1" – reserved	Bit 4 – "1" – reserved
Bit 11 – "1" – error in configuration registers	Bit 3 – "1" – reserved
Bit 10 – "1" – error in displayed screens registers	Bit 2 – "1" – reserved
Bit 9 – "1" – error in registers for configuration of programmable group of registers for readout	Bit 1 – "1" – used battery of RTC
Bit 8 – "1" – energy value error	Bit 0 – reserved

### Status 2 Register – (address 4416, R):

Bit 15 – "1" – condition 3 for alarm 2 signalization	Bit 7 – "1" – condition 3 for alarm 1 signalization
Bit 14 – "1" – condition 2 for alarm 2 signalization	Bit 6 – "1" – condition 2 for alarm 1 signalization
Bit 13 – "1" – condition 1 for alarm 2 signalization	Bit 5 – "1" – condition 1 for alarm 1 signalization
Bit 12 – "1" – alarm 2 signalization	Bit 4 – "1" – alarm 1 signalization
Bit 11 – "1" – alarm 2 condition 3 activated	Bit 3 – "1" – alarm 1 condition 3 activated
Bit 10 – "1" – alarm 2 condition 2 activated	Bit 2 – "1" – alarm 1 condition 2 activated
Bit 9 – "1" – alarm 2 condition 1 activated	Bit 1 – "1" – alarm 1 condition 1 activated
Bit 8 – "1" – alarm 2 activated	Bit 0 – "1" – alarm 1 activated

**Status 3 Register – (address 4417, R): Files archive status**

Bit 15 – reserved	Bit 7 – reserved
Bit 14 – reserved	Bit 6 – reserved
Bit 13 – reserved	Bit 5 – reserved
Bit 12 – reserved	Bit 4 – reserved
Bit 11 – reserved	Bit 3 – reserved
Bit 10 – reserved	Bit 2 – reserved
Bit 9 – reserved	Bit 1 – reserved
Bit 8 – reserved	Bit 0 – reserved

**Status 4 Register – (address 4418, R) reactive power characteristics:**

Bit 15 – reserved	Bit 7 – "1" – capacity L3 min.
Bit 14 – "1" - Demand- capacity 3L max.	Bit 6 – "1" – capacity L3
Bit 13 – "1" - Demand- capacity 3L min.	Bit 5 – "1" – capacity L2 max.
Bit 12 – "1" - Demand- capacity 3L	Bit 4 – "1" – capacity L2 min.
Bit 11 – "1" – capacity 3L max.	Bit 3 – "1" – capacity L2
Bit 10 – "1" – capacity 3L min.	Bit 2 – "1" – capacity L1 max.
Bit 9 – "1" – capacity 3L	Bit 1 – "1" – capacity L1 min.
Bit 8 – "1" – leading L3 max.	Bit 0 – "1" – capacity L1

**Status 5 Register – (address 4419, R)**

Bit 8 – "1" – alarm 1 condition 3 for phase L3 active
Bit 7 – "1" – alarm 1 condition 3 for phase L2 active
Bit 6 – "1" – alarm 1 condition 3 for phase L1 active
Bit 5 – "1" – alarm 1 condition 2 for phase L3 active
Bit 4 – "1" – alarm 1 condition 2 for phase L2 active
Bit 3 – "1" – alarm 1 condition 2 for phase L1 active
Bit 2 – "1" – alarm 1 condition 1 for phase L3 active
Bit 1 – "1" – alarm 1 condition 1 for phase L2 active
Bit 0 – "1" – alarm 1 condition 1 for phase L1 active

**Status 6 Register – (address 4420, R)**

Bit 8 – "1" – alarm 2 condition 3 for phase L3 active
Bit 7 – "1" – alarm 2 condition 3 for phase L2 active
Bit 6 – "1" – alarm 2 condition 3 for phase L1 active
Bit 5 – "1" – alarm 2 condition 2 for phase L3 active
Bit 4 – "1" – alarm 2 condition 2 for phase L2 active
Bit 3 – "1" – alarm 2 condition 2 for phase L1 active
Bit 2 – "1" – alarm 2 condition 1 for phase L3 active
Bit 1 – "1" – alarm 2 condition 1 for phase L2 active
Bit 0 – "1" – alarm 2 condition 1 for phase L1 active

Table 17

Register address	Operations	Range	Description	Default
4600	RW	0 .. 1	The number of the relay for configuration. 0 – relay number one, 1 – relay number two,	0
4601	RW	0 .. 1	Relay function: 0 – standard relay supported by the ND31LITE alarm functions, 1 – function of the Protection relay,	0
4602	RW	0 .. 1	Relay status at the time of the alarm: 0 – disabled, 1 – enabled.	0
4603	RW	0 .. 6	The quantities to which the alarm is to operate: 0 - first phase, 1 - second phase, 2 - third phase, 3 - first and second phase, 4 - first and third phase, 5 - second and third phase, 6 - all phases,	6
4604	RW	0 .. 9	Alarm type 0 - Minimum voltage, 1 - Minimum current, 2 - Maximum voltage, 3 - Maximum current, 4 - Window (voltage), 5 - Window (current), 6 - Phase loss, 7 - Asymmetry (voltage) - available at supervision of at least 2 phases, 8 - Asymmetry (current) - available at supervision of at least 2 phases, 9 - Phase sequence - available with supervision of 3 voltage phases	0
4605	RW	0 .. 2	Latch: 0 - when an alarm occurs, it will not latch, 1 - when an alarm occurs, it will latch, that is, after the alarm condition disappears, it is still active, 2 - resetting the alarm occurrence and returning the relay to the position that occurs when there is no alarm,	0
4606	RW	5 .. 140 [%]	Lower threshold of quantity in percentage (relative to nominal current or voltage)	95
4607	RW	5 .. 140 [%]	Upper threshold in percentage (relative to nominal current or voltage) - upper threshold value cannot be lower than the lower threshold	105
4608	RW	1 .. 30 [%]	Value threshold for asymmetry relative to the nominal value (voltage or current)	3
4609	RW	0 .. 3600 [s]	Delay time (in units of 1s) of alarm activation in seconds - time 0 means the shortest possible activation time resulting from hardware limitations	0
4610	RW	0 .. 3600 [s]	Delay time (in units of 1s) of alarm deactivation in seconds - time 0 means the shortest possible deactivation time resulting from hardware limitations	0

Table 18

16-bit register address 2x16 1032/ 2x16 3210	Register address 32-bit	Operations	Description
7200/7000	7400	R	Content of the register set in the registers 4200
7202/7002	7401	R	Content of the register set in the registers 4201
7204/7004	7402	R	Content of the register set in the registers 4202
7206/7006	7403	R	Content of the register set in the registers 4203
7208/7008	7404	R	Content of the register set in the registers 4204
7210/7010	7405	R	Content of the register set in the registers 4205
7212/7012	7406	R	Content of the register set in the registers 4206
7214/7014	7407	R	Content of the register set in the registers 4207
7216/7016	7408	R	Content of the register set in the registers 4208
7218/7018	7409	R	Content of the register set in the registers 4209
7220/7020	7410	R	Content of the register set in the registers 4210
7222/7022	7411	R	Content of the register set in the registers 4211
7224/7024	7412	R	Content of the register set in the registers 4212
7226/7026	7413	R	Content of the register set in the registers 4213
7228/7028	7414	R	Content of the register set in the registers 4214
7230/7030	7415	R	Content of the register set in the registers 4215
7232/7032	7416	R	Content of the register set in the registers 4216
7234/7034	7417	R	Content of the register set in the registers 4217
7236/7036	7418	R	Content of the register set in the registers 4218
7238/7038	7419	R	Content of the register set in the registers 4219
7240/7040	7420	R	Content of the register set in the registers 4220
7242/7042	7421	R	Content of the register set in the registers 4221
7244/7044	7422	R	Content of the register set in the registers 4222
7246/7046	7423	R	Content of the register set in the registers 4223
7248/7048	7424	R	Content of the register set in the registers 4224
7250/7050	7425	R	Content of the register set in the registers 4225
7252/7052	7426	R	Content of the register set in the registers 4226
7254/7054	7427	R	Content of the register set in the registers 4227
7256/7056	7428	R	Content of the register set in the registers 4228
7258/7058	7429	R	Content of the register set in the registers 4229
7260/7060	7430	R	Content of the register set in the registers 4230
7262/7062	7431	R	Content of the register set in the registers 4231
7264/7064	7432	R	Content of the register set in the registers 4232
7266/7066	7433	R	Content of the register set in the registers 4233
7268/7068	7434	R	Content of the register set in the registers 4234
7270/7070	7435	R	Content of the register set in the registers 4235
7272/7072	7436	R	Content of the register set in the registers 4236
7274/7074	7437	R	Content of the register set in the registers 4237
7276/7076	7438	R	Content of the register set in the registers 4238
7278/7078	7439	R	Content of the register set in the registers 4239
7280/7080	7440	R	Content of the register set in the registers 4240
7282/7082	7441	R	Content of the register set in the registers 4241
7284/7084	7442	R	Content of the register set in the registers 4242
7286/7086	7443	R	Content of the register set in the registers 4243
7288/7088	7444	R	Content of the register set in the registers 4244
7290/7090	7445	R	Content of the register set in the registers 4245
7292/7092	7446	R	Content of the register set in the registers 4246
7294/7094	7447	R	Content of the register set in the registers 4247
7296/7096	7448	R	Content of the register set in the registers 4248
7298/7098	7449	R	Content of the register set in the registers 4249
7300/7100	7450	R	Content of the register set in the registers 4250
7302/7102	7451	R	Content of the register set in the registers 4251

7304/7104	7452	R	Content of the register set in the registers 4252
7306/7106	7453	R	Content of the register set in the registers 4253
7308/7108	7454	R	Content of the register set in the registers 4254
7310/7110	7455	R	Content of the register set in the registers 4255
7312/7112	7456	R	Content of the register set in the registers 4256
7314/7114	7457	R	Content of the register set in the registers 4257
7316/7116	7458	R	Content of the register set in the registers 4258
7318/7118	7459	R	Content of the register set in the registers 4259

Table 19

16-bit register address 2x16 1032/ 2x16 3210	Register address 32-bit	Operations	Description	Unit	3Ph / 4W	3Ph / 3W	1Ph / 2W
6000/8000	7500	R	L1 phase voltage	V	√	x	√
6002/8002	7501	R	L1 phase current	A	√	√	√
6004/8004	7502	R	L1 phase active power	W	√	x	√
6006/8006	7503	R	L1 phase reactive power	VA <sub>r</sub>	√	x	√
6008/8008	7504	R	L1 phase apparent power	VA	√	x	√
6010/8010	7505	R	L1 phase active power factor (PF1=P1/S1))	-	√	x	√
6012/8012	7506	R	tgφ factor of L1 phase (tg1=Q1/P1)	-	√	x	√
6014/8014	7507	R	THD U1*	%	√	x	√
6016/8016	7508	R	THD I1	%	√	x	√
6018/8018	7509	R	L2 phase voltage	V	√	x	x
6020/8020	7510	R	L2 phase current	A	√	√	x
6022/8022	7511	R	L2 phase active power	W	√	x	x
6024/8024	7512	R	L2 phase reactive power	VA <sub>r</sub>	√	x	x
6026/8026	7513	R	L2 phase apparent power	VA	√	x	x
6028/8028	7514	R	L2 phase active power factor (PF2=P2/S2))	-	√	x	x
6030/8030	7515	R	tgφ factor of L2 phase (tg2=Q2/P2)	-	√	x	x
6032/8032	7516	R	THD U2*	%	√	x	x
6034/8034	7517	R	THD I2	%	√	x	x
6036/8036	7518	R	L3 phase voltage	V	√	x	x
6038/8038	7519	R	L3 phase current	A	√	√	x
6040/8040	7520	R	L3 phase active power	W	√	x	x
6042/8042	7521	R	L3 phase reactive power	VA <sub>r</sub>	√	x	x
6044/8044	7522	R	L3 phase apparent power	VA	√	x	x
6046/8046	7523	R	L3 phase active power factor (PF3=P3/S3)	-	√	x	x
6048/8048	7524	R	tgφ factor of L3 phase (tg3=Q3/P3)	-	√	x	x
6050/8050	7525	R	THD U3*	%	√	x	x
6052/8052	7526	R	THD I3	%	√	x	x
6054/8054	7527	R	Mean 3-phase voltage	V	√	x	x
6056/8056	7528	R	Mean 3-phase current	A	√	√	x
6058/8058	7529	R	3-phase active power (P1+P2+P3)	W	√	√	x
6060/8060	7530	R	3-phase reactive power (Q1+Q2+Q3)	VA <sub>r</sub>	√	√	x
6062/8062	7531	R	3-phase apparent power (S1+S2+S3)	VA	√	√	x
6064/8064	7532	R	3-phase active power factor (PF=P/S)	-	√	√	x
6066/8066	7533	R	Mean tg factor φ for 3 phases (tg=Q/P)	-	√	√	x
6068/8068	7534	R	THD U* mean 3-phase	%	√	x	x
6070/8070	7535	R	THD I mean 3-phase	%	√	x	x

6072/8072	7536	R	Frequency	f	√	√	√
6074/8074	7537	R	Phase-to-phase voltage L <sub>1-2</sub>	V	√	√	x
6076/8076	7538	R	Phase-to-phase voltage L <sub>2-3</sub>	V	√	√	x
6078/8078	7539	R	Phase-to-phase voltage L <sub>3-1</sub>	V	√	√	x
6080/8080	7540	R	Mean phase-to-phase voltage	V	√	√	x
6082/8082	7541	R	Active power averaged (P Demand)	W	√	√	x
6084/8084	7542	R	Reactive power averaged (S Demand )	VA	√	√	x
6086/8086	7543	R	Current averaged (I Demand)	A	√	√	x
6088/8088	7544	R	Neutral wire current (calculated from vectors)	A	√	x	x
6090/8090	7545	R	Active 3-phase import energy (no. of register 7546 overflows, resets to 0 after reaching 9999.9 MWh)	100 MWh	√	√	√
6092/8092	7546	R	Active 3-phase import energy (counter counting up to 99999.99 kWh)	kWh	√	√	√
6094/8094	7547	R	Active 3-phase export energy (no. of register 7548 overflows, resets to 0 after reaching 9999.9 MWh)	100 MWh	√	√	√
6096/8096	7548	R	Active 3-phase export energy (counter counting up to 99999.99 kWh)	kWh	√	√	√
6098/8098	7549	R	Reactive 3-phase inductive energy (no. of register 7550 overflows, resets to 0 after reaching 9999.9 MVAh).	100 MVAh	√	√	√
6100/8100	7550	R	Reactive 3-phase inductive energy (counter counting up to 99999.99 kVAh)	kVAh	√	√	√
6102/8102	7551	R	Reactive 3-phase capacity energy (no. of register 7552 overflows, resets to 0 after reaching 9999.9 MVAh)	100 MVAh	√	√	√
6104/8104	7552	R	Reactive 3-phase capacity energy (counter counting up to 99999.99 kVAh)	kVAh	√	√	√
6106/8106	7553	R	Apparent energy (no. of register 7554 overflows, resets to 0 after reaching 9999.9 MVAh)	100 MVAh	√	√	√
6108/8108	7554	R	Apparent energy (counter counting up to 99999.99 kVAh)	kVAh	√	√	√
6110/8110	7555	R	Time – seconds	sec	√	√	√
6112/8112	7556	R	Time – hours, minutes		√	√	√
6114/8114	7557	R	Date – month, day		√	√	√
6116/8116	7558	R	Year – 2014 - 2100		√	√	√
6118/8118	7559	R	Status 1 register	-	√	√	√
6120/8120	7560	R	Status 2 register	-	√	√	√
6122/8122	7561	R	Status 3 register	-	√	√	√
6124/8124	7562	R	Status 4 register	-	√	√	√
6126/8126	7563	R	Status 5 register	-	√	√	√
6128/8128	7564	R	Status 6 register	-	√	√	√
6130/8130	7565	R	reserved				
6132/8132	7566	R	reserved				
6134/8134	7567	R	reserved				
6136/8136	7568	R	Voltage L1 min	V	√	x	√
6138/8138	7569	R	Voltage L1 max	V	√	x	√
6140/8140	7570	R	Voltage L2 min	V	√	x	x
6142/8142	7571	R	Voltage L2 max	V	√	x	x
6144/8144	7572	R	Voltage L3 min	V	√	x	x
6146/8146	7573	R	Voltage L3 max	V	√	x	x
6148/8148	7574	R	Current L1 min	A	√	√	x
6150/8150	7575	R	Current L1 max	A	√	√	x
6152/8152	7576	R	Current L2 min	A	√	√	x
6154/8154	7577	R	Current L2 max	A	√	√	x

6156/8156	7578	R	Current L3 min	A	√	√	x
6158/8158	7579	R	Current L3 max	A	√	√	x
6160/8160	7580	R	Active power L1 min	W	√	x	√
6162/8162	7581	R	Active power L1 max	W	√	x	√
6164/8164	7582	R	Active power L2 min	W	√	x	x
6166/8166	7583	R	Active power L2 max	W	√	x	x
6168/8168	7584	R	Active power L3 min	W	√	x	x
6170/8170	7585	R	Active power L3 max	W	√	x	x
6172/8172	7586	R	Reactive power L1 min	Var	√	x	√
6174/8174	7587	R	Reactive power L1 max	Var	√	x	√
6176/8176	7588	R	Reactive power L2 min	Var	√	x	x
6178/8178	7589	R	Reactive power L2 max	Var	√	x	x
6180/8180	7590	R	Reactive power L3 min	Var	√	x	x
6182/8182	7591	R	Reactive power L3 max	Var	√	x	x
6184/8184	7592	R	Apparent power L1 min	VA	√	x	√
6186/8186	7593	R	Apparent power L1 max	VA	√	x	√
6188/8188	7594	R	Apparent power L2 min	VA	√	x	x
6190/8190	7595	R	Apparent power L2 max	VA	√	x	x
6192/8192	7596	R	Apparent power L3 min	VA	√	x	x
6194/8194	7597	R	Apparent power L3 max	VA	√	x	x
6196/8196	7598	R	Power factor (PF) L1 min	-	√	x	√
6198/8198	7599	R	Power factor (PF) L1 max	-	√	x	√
6200/8200	7600	R	Power factor (PF) L2 min	-	√	x	x
6202/8202	7601	R	Power factor (PF) L2 max	-	√	x	x
6204/8204	7602	R	Power factor (PF) L3 min	-	√	x	x
6206/8206	7603	R	Power factor (PF) L3 max	-	√	x	x
6208/8208	7604	R	Reactive to active power ratio L1 min	-	√	x	√
6210/8210	7605	R	Reactive to active power ratio L1 max	-	√	x	√
6212/8212	7606	R	Reactive to active power ratio L1 min	-	√	x	x
6214/8214	7607	R	Reactive to active power ratio L2 max	-	√	x	x
6216/8216	7608	R	Reactive to active power ratio L3 min	-	√	x	x
6218/8218	7609	R	Reactive to active power ratio L3 max	-	√	x	x
6220/8220	7610	R	Phase-to-phase voltage L <sub>1-2</sub> min	V	√	√	x
6222/8222	7611	R	Phase-to-phase voltage L <sub>1-2</sub> max	V	√	√	x
6224/8224	7612	R	Phase-to-phase voltage L <sub>2-3</sub> min	V	√	√	x
6226/8226	7613	R	Phase-to-phase voltage L <sub>2-3</sub> max	V	√	√	x
6228/8228	7614	R	Phase-to-phase voltage L <sub>3-1</sub> min	V	√	√	x
6230/8230	7615	R	Phase-to-phase voltage L <sub>3-1</sub> max	V	√	√	x
6232/8232	7616	R	Mean 3-phase voltage (min)	V	√	x	x
6234/8234	7617	R	Mean 3-phase voltage (max)	V	√	x	x
6236/8236	7618	R	Mean 3-phase current (min)	A	√	√	x
6238/8238	7619	R	Mean 3-phase current (max)	A	√	√	x
6240/8240	7620	R	3-phase active power (min)	W	√	√	x
6242/8242	7621	R	3-phase active power (max)	W	√	√	x
6244/8244	7622	R	3-phase reactive power (min)	var	√	√	x
6246/8246	7623	R	3-phase reactive power (max)	var	√	√	x
6248/8248	7624	R	3-phase apparent power (min)	VA	√	√	x
6250/8250	7625	R	3-phase apparent power (max)	VA	√	√	x
6252/8252	7626	R	Power factor (PF) min	-	√	√	x
6254/8254	7627	R	Power factor (PF) max	-	√	√	x

6256/8256	7628	R	Reactive to active power ratio (3-phase mean min.)	-	√	√	x
6258/8258	7629	R	Reactive to active power ratio (3-phase mean max.)	-	√	√	x
6260/8260	7630	R	Min. frequency	Hz	√	√	√
6262/8262	7631	R	Frequency max	Hz	√	√	√
6264/8264	7632	R	Mean phase-to-phase voltage (min.)	V	√	√	x
6266/8266	7633	R	Mean phase-to-phase voltage (max.)	V	√	√	x
6268/8268	7634	R	Active power averaged (P Demand) min	W	√	√	√
6270/8270	7635	R	Active power averaged (P Demand) max	W	√	√	√
6272/8272	7636	R	Apparent power averaged (S Demand) min	VA	√	√	√
6274/8274	7637	R	Apparent power averaged (S Demand) max	VA	√	√	√
6276/8276	7638	R	Current averaged (I Demand) min	A	√	√	√
6278/8278	7639	R	Current averaged (I Demand) max	A	√	√	√
6280/8280	7640	R	Neutral wire current (min.)	A	√	x	x
6282/8282	7641	R	Neutral wire current (max.)	A	√	x	x
6284/8284	7642	R	reserved				
6286/8286	7643	R	reserved				
6288/8288	7644	R	reserved				
6290/8290	7645	R	reserved				
6292/8292	7646	R	THD U1 min	%	√	x	√
6294/8294	7647	R	THD U1 max	%	√	x	√
6296/8296	7648	R	THD U2 min	%	√	x	x
6298/8298	7649	R	THD U2 max	%	√	x	x
6300/8300	7650	R	THD U3 min	%	√	x	x
6302/8302	7651	R	THD U3 max	%	√	x	x
6304/8304	7652	R	THD U min	%	√	x	x
6306/8306	7653	R	THD U max	%	√	x	x
6308/8308	7654	R	THD I1 min	%	√	x	√
6310/8310	7655	R	THD I1 max	%	√	x	√
6312/8312	7656	R	THD I2 min	%	√	x	x
6314/8314	7657	R	THD I2 max	%	√	x	x
6316/8316	7758	R	THD I3 min	%	√	x	x
6318/8318	7759	R	THD I3 max	%	√	x	x
6320/8320	7660	R	THD I min	%	√	x	x
6322/8322	7661	R	THD I max	%	√	x	x
6324/8324	7662	R	HarU1[2] 2nd harmonic of L1 phase voltage	%	√	x	√
6326/8326	7663	R	HarU1[3] 3rd harmonic of L1 phase voltage	%	√	x	√
:	:	R	:				
:	:	R	:				
6420/8420	7710	R	HarU1[50] 50th harmonic of L1 phase voltage	%	√	x	√
6422/8422	7711	R	HarU1[51] 51st harmonic of L1 phase voltage	%	√	x	√
6424/8424	7712	R	HarU2[2] 2nd harmonic of L2 phase voltage	%	√	x	x
6426/8426	7713	R	HarU2[3] 3rd harmonic of L2 phase voltage	%	√	x	x
:	:	R	:				
:	:	R	:				
6520/8520	7760	R	HarU2[50] 50th harmonic of L2 phase voltage	%	√	x	x
6522/8522	7761	R	HarU2[51] 51st harmonic of L2 phase voltage	%	√	x	x
6524/8524	7762	R	HarU3[2] 2nd harmonic of L3 phase voltage	%	√	x	x
6526/8526	7763	R	HarU3[3] 3rd harmonic of L3 phase voltage	%	√	x	x
:	:	R	:				
:	:	R	:				
6620/8620	7810	R	HarU3[50] 50th harmonic of L3 phase voltage	%	√	x	x
6622/8622	7811	R	HarU3[51] 51st harmonic of L3 phase voltage	%	√	x	x

6624/8624	7812	R	Har1U1[2] 2nd harmonic of L1 phase current	%	√	x	√
6626/8626	7813	R	Har1U1[3] 3rd harmonic of L1 phase current	%	√	x	√
:	:	R	:				
:	:	R	:				
6720/8720	7860	R	Har1U1[50] 50th harmonic of L1 phase current	%	√	x	√
6722/8722	7861	R	Har1[51] 51st harmonic of L1 phase current	%	√	x	√
6724/8724	7862	R	Har2[2] 2nd harmonic of L2 phase current	%	√	x	x
6726/8726	7863	R	Har2[3] 3rd harmonic of L2 phase current	%	√	x	x
:	:	R	:				
:	:	R	:				
6820/8820	7910	R	Har2[50] 50th harmonic of L2 phase current	%	√	x	x
6822/8822	7911	R	Har2[51] 51st harmonic of L2 phase current	%	√	x	x
6824/8824	7912	R	Har3[2] 2nd harmonic of L3 phase current	%	√	x	x
6826/8826	7913	R	Har3[3] 3rd harmonic of L3 phase current	%	√	x	x
:	:	R	:				
:	:	R	:				
6920/8920	7960	R	Har3[50] 50th harmonic of L3 phase current	%	√	x	x
6922/8922	7961	R	Har3[51] 51st harmonic of L3 phase current	%	√	x	x
6924/8924	7962	R	Mean reactive power	var	√	√	√
6926/8926	7963	R	Mean reactive power min	var	√	√	√
6928/8928	7964	R	Mean reactive power max	var	√	√	√
6930/8930	7965	R	Mean active power factor (PF1+PF2+PF3)/3	-	√	x	√
6932/8932	7966	R	Mean active power factor min	-	√	x	√
6934/8934	7967	R	Mean active power factor max	-	√	x	√
6936/8936	7968	R	Active imported 3-phase energy for the previous year (overflows number of register 7563, reset after 9999.9 MWh is reached)	100 MWh	√	√	√
6938/8938	7969	R	Active imported 3-phase energy for the previous year (counter up to 9999.99 kWh)	kWh	√	√	√
6940/8940	7970	R	Active exported 3-phase energy for the previous year (overflows number of register 7565, reset after 9999.9 MWh is reached)	100 MWh	√	√	√
6942/8942	7971	R	Active exported 3-phase energy for the previous year (counter up to 9999.99 kWh)	kWh	√	√	√
6944/8944	7972	R	Active imported 3-phase energy for the current year (overflows number of register 7567, reset after 9999.9 MWh is reached)	100 MWh	√	√	√
6946/8946	7973	R	Active imported 3-phase energy for the current year (counter up to 9999.99 kWh)	kWh	√	√	√
6948/8948	7974	R	Active exported 3-phase energy for the current year (overflows number of register 7569, reset after 9999.9 MWh is reached)	100 MWh	√	√	√
6950/8950	7975	R	Active exported 3-phase energy for the current year (counter up to 9999.99 kWh)	kWh	√	√	√
6952/8952	7976	R	Active imported 3-phase energy for the current month (overflows number of register 7571, reset after 9999.9 MWh is reached)	100 MWh	√	√	√
6954/8954	7977	R	Active imported 3-phase energy for the current month (counter up to 9999.99 kWh)	kWh	√	√	√
6956/8956	7978	R	Active exported 3-phase energy for the current month (overflows number of register 7573, reset after 9999.9 MWh is reached)	100 MWh	√	√	√
6958/8958	7979	R	Active exported 3-phase energy for the current month (counter up to 9999.99 kWh)	kWh	√	√	√

6960/8960	7980	R	Active imported 3-phase energy for the current week (overflows number of register 7575, reset after 9999.9 MWh is reached)	100 MWh	√	√	√
6962/8962	7981	R	Active imported 3-phase energy for the current week (counter up to 9999.99 kWh)	kWh	√	√	√
6964/8964	7982	R	Active exported 3-phase energy for the current week (overflows number of register 7577, reset after 9999.9 MWh is reached)	100 MWh	√	√	√
6966/8966	7983	R	Active exported 3-phase energy for the current week (counter up to 9999.99 kWh)	kWh	√	√	√
6968/8968	7984	R	Active imported 3-phase energy for the current 48 hours (overflows number of register 7579, reset after 9999.9 MWh is reached)	100 MWh	√	√	√
6970/8970	7985	R	Active imported 3-phase energy for the current 48 hours (counter up to 9999.99 kWh)	kWh	√	√	√
6972/8972	7986	R	Active exported 3-phase energy for the current 48 hours (overflows number of register 7581, reset after 9999.9 MWh is reached)	100 MWh	√	√	√
6974/8974	7987	R	Active exported 3-phase energy for the current 48 hours (counter up to 9999.99 kWh)	kWh	√	√	√
6976/8976	7988	R	Active imported 3-phase energy for the current 24 hours (overflows number of register 7583, reset after 9999.9 MWh is reached)	100 MWh	√	√	√
6978/8978	7989	R	Active imported 3-phase energy for the current 24 hours (counter up to 9999.99 kWh)	kWh	√	√	√
6980/8980	7990	R	Active exported 3-phase energy for the current 24 hours (overflows number of register 7585, reset after 9999.9 MWh is reached)	100 MWh	√	√	√
6982/8982	7991	R	Active exported 3-phase energy for the current 24 hours (counter up to 9999.99 kWh)	kWh	√	√	√

\* In three-phase 3-wire (3Ph/3W) system, respectively THD U12, THD U23, THD U31, THD U123

Table 20

Register address 16 bit 2x16 1032/ 2x16 3210	Operations	Description	Unit	3Ph	3Ph	1Ph
				/ 4W	/ 3W	/ 2W
9000/9200	R	HarU1[52] 52nd harmonic of L1 phase voltage	%	√	x	√
9002/9202	R	HarU1[53] 53rd harmonic of L1 phase voltage	%	√	x	√
:	R	:				
:	R	:				
9020/9220	R	HarU1[62] 62nd harmonic of L1 phase voltage	%	√	x	√
9022/9222	R	HarU1[63] 63rd harmonic of L1 phase voltage	%	√	x	√
9024/9224	R	HarU2[52] 52nd harmonica of L2 phase voltage	%	√	x	x
9026/9226	R	HarU2[53] 53rd harmonic of L2 phase voltage	%	√	x	x
:	R	:				
:	R	:				
9044/9244	R	HarU2[62] 62nd harmonic of L2 phase voltage	%	√	x	x
9046/9246	R	HarU2[63] 63rd harmonic of L2 phase voltage	%	√	x	x
9048/9248	R	HarU3[52] 52nd harmonic of L3 phase voltage	%	√	x	x
9050/9250	R	HarU3[53] 53rd harmonic of L3 phase voltage	%	√	x	x
:	R	:				
:	R	:				

9068/9268	R	HarU3[62]	62nd harmonic of L3 phase voltage	%	√	X	X
9070/9270	R	HarU3[63]	63rd harmonic of L3 phase voltage	%	√	X	X
9072/9272	R	Har1[52]	52nd harmonic of L1 current voltage	%	√	X	√
9074/9274	R	Har1[53]	53rd harmonic of L1 current voltage	%	√	X	√
:	R	:					
:	R	:					
9092/9292	R	Har1[62]	62nd harmonic of L1 current voltage	%	√	X	√
9094/9294	R	Har1[63]	63rd harmonic of L1 current voltage	%	√	X	√
9096/9296	R	Har2[52]	52nd harmonica of L2 current voltage	%	√	X	X
9098/9298	R	Har2[53]	53rd harmonic of L2 current voltage	%	√	X	X
:	R	:					
:	R	:					
9116/9316	R	Har2[62]	62nd harmonic of L2 current voltage	%	√	X	X
9118/9318	R	Har2[63]	63rd harmonic of L2 current voltage	%	√	X	X
9120/9320	R	Har3[52]	52nd harmonica of L3 current voltage	%	√	X	X
9122/9322	R	Har3[53]	53rd harmonic of L3 current voltage	%	√	X	X
:	R	:					
:	R	:					
9140/9340	R	Har3[62]	62nd harmonic of L3 current voltage	%	√	X	X
9142/9342	R	Har3[63]	63rd harmonic of L3 current voltage	%	√	X	X

## 10 SOFTWARE UPGRADE

### 10.1 Firmware update

A feature implemented in the ND31LITE meters enables to upgrade firmware using a PC with eCon software installed. Free eCon software and the update files are available at manufacturer's website. Upgrade of meter software (firmware) can be done via RS-485 interface. Go to LUMEL UPDATER tab to upgrade.

a)

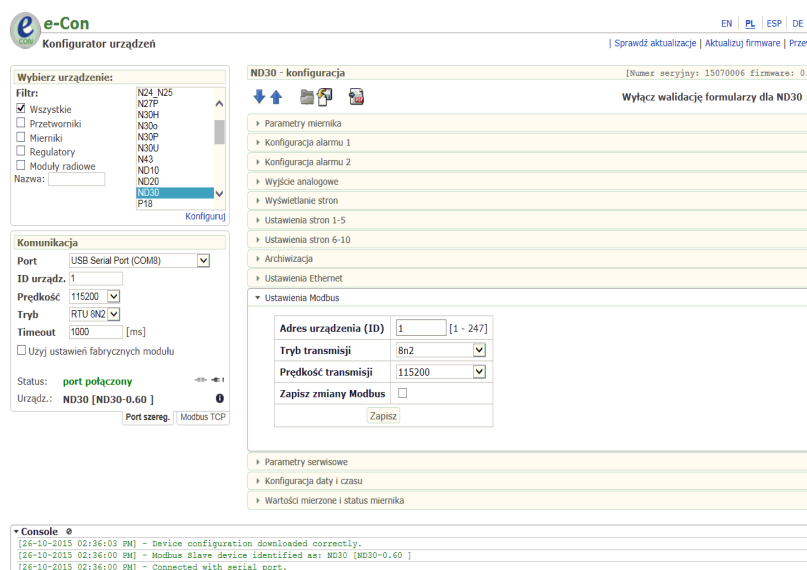

b)

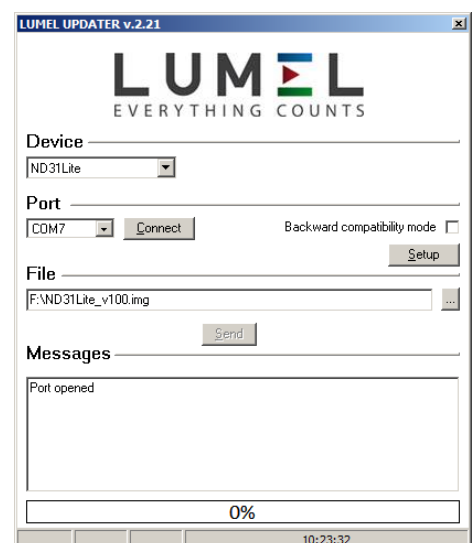



Fig.26. Program window view: a) eCon, b) software upgrade

**Note:** Software update automatically resets meter settings to default settings, so it is recommended to save meter settings using eCon software before upgrading.

After launching eCon software, set in the settings required serial port, baud rate, mode and address of the meter. Next, select the ND31LITE meter and click *Config*. Click the down arrow icon to read all of the settings then the disk icon to save the settings to a file (required to restore the settings later). After selecting the option *Update firmware* (in the upper right corner of the screen) the window *Lumel Updater (LU)* will be opened – Fig. 26b.

There are two ways to enter upgrade mode in the meter:

1. remotely via LU (based on the settings in eCon - address, mode, baud rate, COM port)
2. by switching on the meter with the key  held down (if the bootloader mode is entered with the key, the communication parameters are: baud rate 9600, RTU8N2, address 1).

Select the meter update file by pressing the "..." button. Click *Connect*. **(NOTE! for the 2nd update method, the meter must be switched on at this time)**. The *Messages* information window displays information concerning upgrade process. If the port is opened correctly, a *Port opened* message appears.

The display will show the bootloader version, while the LU program displays the message *Device found* and the name and version of the connected device. Press the *Send* button. When upgrade is successfully completed, the meter begins normal work while the information window displays *Done* message and upgrade elapsed time.

After the LU window is closed, go to parameter group *Service parameters*, select the option *Set default settings of a meter* and press a button *Restore*. Then press the folder icon to open a previously saved settings file and press the up arrow icon to save the settings in the meter. Current software version can be checked by reading the welcome message when switching the meter on.

Note: Turning meter supply off during upgrade process may result in permanent damage!

## 11 ERROR CODES

During the meter operation the error messages may be displayed. Following list shows reasons of errors.

### Error:

**MEMORY FR, - CAL INP** – displayed when the memory of the meter is corrupted. The meter must be sent to the manufacturer.

**PAR.CFG** – displayed when the operating parameters of the meter are incorrect. The factory settings must be restored (from the menu "Settings -> Set all defaults" or via RS485).

**PAR.SCREEN** – displayed when the parameters related to the configuration of displayed parameters in the meter are incorrect. The factory settings should be restored (from the menu "Displaying -> Settings -> Set screen defaults "or via RS485).

**PAR.READ** – displayed when the parameters related to registers from the modbus 42xx group of addresses are incorrect. The factory settings must be restored (from the menu " Modbus -> Set defaults 42xx" or via RS485).

**ENERGY** – displayed when an error occurs in the value in one of the energy counters of the meter. The factory settings must be restored (from the menu " Parameters -> Del energy counters" or via RS485).

- ^^^^ – upper overrun. Measuring value is out of the measuring range.
- vvvv – lower overrun. Measuring value is out of the measuring range.

## 12 TECHNICAL DATA

### Measuring ranges and permissible basic errors

Table 20\

Measuring value	Measuring range	L1	L2	L3	$\Sigma$	Class
Current I 1/5 A 1 A~ 5 A~	0.002 ..0.100..1.200 A 0.010 ..0.500.. 6.000 A ...100.00 kA (tr I $\neq$ 1)	•	•	•		0.2 (EN 61557-12)
Voltage U L-N: 57.7 V~ 110 V~ 230 V~	5.700..11.500 ..70.000 V 11.000..22.000 ..132.00 V 23.000..46.000 .. 276.00 V ...1920.0 kV (tr U $\neq$ 1)	•	•	•		0.2 (EN 61557-12)
Voltage U L-L: 100 V~ 190 V~ 400 V~	10.000 ..20.000..120.00 V 19.000 ..38.000..228.00 V 40.000..80.00 .. 480.00 V ...1999.0 kV (tr U $\neq$ 1)	•	•	•		0.5 (EN 61557-12)
Active power P	-19999 MW .. 0.000 W .. ..19999 MW (tr U $\neq$ 1, tr I $\neq$ 1)	•	•	•	•	0.5 (EN 61557-12)
Reactive power Q	-19999 MVar .. 0.000 Var .. ..19999 MVar (tr U $\neq$ 1, tr I $\neq$ 1)	•	•	•	•	2 (EN 61557-12)
Apparent power S	0.000 .. 1999,9 VA .. ..19999 MVA (tr U $\neq$ 1, tr I $\neq$ 1)	•	•	•	•	0.5 (EN 61557-12)
Active energy EnP / import or export /	0.000 .. 99 999 999.999 kWh				•	0.2S (EN 62053-22)
Reactive energy EnQ / capacity or inductive /	0.000 .. 99 999 999.999 kVarh				•	1 (EN 61557-12)
Apparent energy EnS	0.000 .. 99 999 999.999 kVAh				•	0.5 (EN 61557-12)
Active power factor PF	-1.00 .. 0 .. 1.00	•	•	•	•	1 (EN 61557-12)
Factor tg	-999.99 ..-1.20 .. 0 .. 1.20.. 999.99	•	•	•	•	1
Frequency f	45.000 ...65.000..100 Hz				•	0.1 (EN 61557-12)
Harmonic distortion factor of voltage THDU, current THDI	0.0 .. 100.0%	•	•	•	•	5 (EN 61557-12)
Harmonic amplitudes of voltage U <sub>h2</sub> ...U <sub>h63</sub> , of current I <sub>h2</sub> ... I <sub>h63</sub>	0.0 .. 100.0%	•	•	•		II (IEC61000-4-7)

tr\_I - Current transformer ratio = Transformer primary current / Current transformer secondary current

tr\_U - Voltage transformer ratio = Transformer primary voltage / Voltage transformer secondary voltage

**Power consumption:**

- in supply circuit	≤ 6 VA
- in voltage circuit	≤ 0.5 VA
- in current circuit	≤ 0.1 VA

**Readout field**

3.5" TFT full-color screen, resolution: 320 x 240 pixel

**Relay outputs (A1, A2)**

2 programmable relays, volt-free NO contacts, load capacity (resistive) 0.5 A/250 V AC or 5 A/30 V DC  
 Switching number: mechanical min.  $5 \times 10^6$   
 electric min.  $1 \times 10^5$

**Serial interface RS-485**

Modbus RTU 8N2, 8E1, 8O1, 8N1. Address 1..247,  
 Baud rate 4.8, 9.6, 19.2, 38.4, 57.6, 115.2 kbit/s  
 Maximum response time: 600 ms

**Sampling**

A/D Converter 16-bit  
 sampling rate 6.4 kHz at 50 Hz  
 7.68 kHz at 60 Hz  
 Simultaneous sampling of all loops, 128 samples per cycle

**Harmonics**

Harmonic (n) 1..63  
 Harmonic distortion factor referred to the voltage THD,  
 current THD (n=2..63) 0.0 ..100.0%  
 FFT analysis (Fast Fourier Transform)

**Real Time Clock**

±20 ppm, real time clock battery CR2032

**Terminals**

Cross section	0.05 .. 2.5 mm <sup>2</sup>
Clamping screws	M3
Tightening torque	0.5 Nm

**Protection grade ensured by the housing**

from the front	IP 65
from terminals side	IP 20

**Weight**

0.3 kg

**Overall dimensions**

96 x 96 x 77 mm

**Reference and rated operating conditions**

- supply voltage	85..253 V a.c. (40.. <u>50</u> ..400 Hz), 90..300 V d.c.
- input signal:	0 .. <u>0.1</u> .. <u>1.2I<sub>n</sub></u> ; 0.1.. <u>0.2</u> .. <u>1.2U<sub>n</sub></u> for current, voltage, PF <sub>i</sub> , tg <sub>i</sub>
- frequency	45 .. <u>50</u> .. <u>60</u> .. 100 Hz; sinusoidal (THD ≤ 8%)
- power factor	<u>-1</u> .. <u>0</u> .. <u>1</u>
- ambient temperature	-10.. <u>23</u> ..+55 °C, class K55 acc. to EN61557-12
- storage temperature	-20..+70 °C
- humidity	0 .. <u>40</u> .. <u>60</u> ..95% (no condensation)

- max. peak factor:
  - current 2
  - voltage 2
- external magnetic field  $\leq 40 \dots 400$  A/m d.c.  
 $\leq 3$  A/m a.c. 50/60 Hz
- short-term overload
  - voltage inputs 5 sec. 2 Un
  - current inputs 1 sec. 50 A
- working position any
- warm-up time 15 min.

**Real time clock battery:** CR2032

**Additional errors:**

in % of the base error

- from ambient temperature changes < 50% / 10 °C
- for THD > 8% < 50%

**Standards fulfilled by the meter:**

**Electromagnetic compatibility:**

- noise immunity in industrial environments acc. to EN 61000-6-2, EN IEC 61326-1
- radio-frequency common mode:
  - level 2: 0.15... 1 MHz
  - level 3: 1 MHz...80 MHz
- noise emission acc. to EN 61000-6-4, EN IEC 61326-1

**Safety requirements:**

according to EN 61010-1 (with changes) standard

- isolation between circuits: basic
- OVC surge category III for voltages with respect to ground up to 300V (for input voltages 3 x 57.7/100 V, 3 x 230/400 V),
- pollution grade: 2,
- maximum phase-to-earth operating voltage:
  - for supply circuits and relay outputs: 300 V
  - for measurement input: 500 V
  - for RS-485 circuits: 50 V
- altitude a.s.l. < 2000 m,

## 13 ORDERING CODE

ND31LITE network parameters meter ordering code.

Table 45

ND31LITE	X	X	X	X	X	X	XXXX
<b>Input voltage (phase/phase-to-phase)Un:</b> 3 x 57.7/100 V, 3 x 230/400 V	1						
<b>Additional outputs/inputs:</b> 2x relay		1					
<b>Interfaces:</b> RS485			1				
<b>Supply voltage:</b> 85..253 V a.c., 90..300 V d.c.				1			
<b>Language:</b> polish/english						M	
other*						X	
<b>Acceptance tests:</b> without additional quality requirements							0
with an extra quality inspection certificate							1
with an extra calibration certificate							2
acc.to customer's request*							X
<b>Version:</b> standard							
custom-made*							XXXX

\* only by agreement with the manufacturer

ORDER EXAMPLE, code **ND31LITE 1111M0** means:

- ND31LITE** - ND31LITE meter,
- 1** - input voltage 3 x 57.7/100 V, 3 x 230/400 V,
- 1** - 2 x relay,
- 1** – RS485,
- 1** - supply voltage 85..253 V a.c., 90..300 V d.c.
- M** - Polish-English language version,
- 0** - no additional requirements,
- standard version.

