

# Technical Data Sheet

## *Alpha 20*



File No. E471457



**Alpha 20** Alpha 20 measures important electrical parameters in 3 phase 4 Wire, 1 phase 2 wire, 1 phase 3 wire (Split Phase) and 3 phase 3 Wire Network & replaces the multiple analog panel meters.. It measures electrical parameters like AC voltage, AC Current, Frequency, Active, Reactive, Apparent Power, Import & Export Energy & many more.

### Special Features

- Fast & Easy Installation on panel with self clicking.
- True RMS measurement
- MODBUS (Rs485) Communication (optional).
- Pulse/Limit Switch output (optional).
- 3 Line 4 Digits ultra bright LED Display (up to 9999).
- On site Programmable CT/PT Ratios
- User selectable CT Secondary 1A/5A
- User selectable PT Secondary from 100 VLL to 500 VLL
- User selectable 3ph3wire/ 3ph4wire/ 1ph3wire (split Phase)/ single phase Network
- Programmable Energy format & Energy rollover count
- Wide Auxiliary Power Supply which can accept any input between 40V - 300V AC/DC or 12V - 48V DC.
- Storage of MIN / MAX values.
- Measurement & Display of RPM, Run hours, On hours, No. of interruption.

## Application

Alpha 20 measures important electrical parameters in 3 phase 4 Wire, 1 Phase 3 Wire (Split Phase) and 3 phase 3 Wire Network & replaces the multiple analog panel meters. It measures electrical parameters like AC Voltage, AC Current, Frequency, Active, Reactive, Apparent Power, Import & Export Energy & many more.

## Product Features

### On site programmable PT/ CT ratios

It is possible to program primary of external potential Transformer (PT), primary of external Current Transformer (CT) on site via front panel keys by entering into Programming mode.

### User selectable CT Secondary 5A/ 1A

The secondary of external Current Transformer (CT) can be programmed on site to either 5A or 1A using front panel keys.

### User selectable PT Secondary

The secondary of external Potential Transformer (PT) can be programmed on site from 100VLL to 500VLL using front panel keys. User can set the display in auto scrolling mode or fixed screen mode using front panel keys.

### Low back depth

The instrument has very low back depth (behind the panel) of less than 55 mm (Without output option).

### Four function keys

Using the four function key, it is possible to go desired parameter screen instantly..

### Demand Measurement

Measures & Displays Current Demand, kVA Demand, kW Import Demand, kW Export Demand. Any of the parameters can be assigned to optional Limit switch.

### True RMS measurement

The instrument measures distorted waveform up to 15th Harmonic.

### Energy Measurement (Import & Export)

Active Energy (kWh), Reactive Energy (kVAh), Apparent Energy (VAh). Any of the parameters can be assigned to optional Pulse output.

### Programmable Energy format & Energy rollover count

Customer can assign the format for energy display on MODBUS (RS485) in terms of W, kW or MW. Additional to this, customer can also set a rollover count from 7 to 14 digits depending on the energy format, after which the energy will roll back to zero.

### Optional Pulse Output/ Limit switch (Relay output)

The instrument can be programmed as Pulse output or Limit switch.

### Pulse Output

The optional pulse output is a **potential free**, very fast acting relay contact which can be used to drive an external mechanical counter for energy measurement.

### Limit Switch

The instrument will trip the relay if the programmed parameter exceeds the programmed Trip Limits.

### Optional MODBUS (RS485) Output

The optional Modbus output enables the instrument to transmit all the measured parameters over standard MODBUS (Rs485).

### Configuration of Instrument via MODBUS

The instrument setting can be configured locally via front panel keys by entering into the programming mode or remotely via MODBUS (Rs485).

**Note:** The MODBUS communication parameters can only be set locally via front panel keys in programming mode.

## Product Features

### Storage of parameters possible

The instrument stores minimum and maximum values for System Voltage, System Current, Run Hour, ON Hour & number of Interrupts. Every 60 sec stored values are updated.

### 3 line 4 digits LED display

Simultaneous display of 3 Parameters.

### RPM Measurement

The instrument display Rotation per minutes for generator applications. Number of poles can be set on site depending upon application requirement.

### Energy Count Storage

In case of power failure, the instrument memorizes the last energy count. Every 1 min, the instrument updates the energy counter in the non-volatile memory

### User selectable 3 phase 3 Wire or 4 Wire or 1 phase 3 Wire (Split Phase) or Single phase Network

User can program on site the network connection as either 3 Phase 3 Wire or 4 Wire or 1 phase 3wire (Split phase) or single phase network using front panel keys.

In case of self powered Alpha 20 only either 3 Phase 4 wire, single phase & 1 Phase 3 Wire network are available.

### Onsite selection of Auto scroll/ Fixed Screen

User can set the display in auto scrolling mode or fixed screen mode using front panel keys.

## Technical Specifications

### Input Voltage :

Nominal input voltage (AC RMS)	Phase -Neutral 290V L-N , Line-Line 500V L-L
Max continuous input voltage	120% of rated value
Nominal input voltage burden	< 0.3 VA approx. per phase (For external auxiliary meter)
System PT secondary values	100VLL to 500VLL programmable on site.
System PT primary values	100VLL to 692kVLL programmable on site.

### Input Current:

Nominal input voltage current	5A / 1A AC RMS
System CT secondary values	1A & 5A programmable on site.
System CT primary values	From 1A up to 9999A (for 1 or 5 Amp)
Max continuous input current	120% of rated value
Nominal input current burden	< 0.2 VA approx. per phase

### Auxiliary Supply

External Aux DC Auxiliary Supply	40 V - 300V AC-DC ( $\pm 5\%$ ) 12V - 48V DC
Self power	input voltage range from 80% to 100% of Rated value. (Self power meter is available only in 3Phase 4 Wire, Split Phase and Single Phase network) Auxiliary input is derived from Phase 1 (R phase)
Frequency range VA burden	45 to 65 Hz < 4 VA Approx

### Overload Withstand

Voltage	2 x rated value for 1 second, repeated 10 times at 10 second intervals
---------	--

### Operating Measuring Ranges:

Voltage Range With External Aux	10... 120% of rated value
Voltage Range With Self Power	80... 120% of rated value
Current Range	10 ... 120% of rated value
Frequency	45...65 Hz.
Power Factor	0.5 Lead ... 1 ... 0.5 Lag.

## Technical Specifications

### Reference conditions for Accuracy

Reference temperature	23°C +/- 2°C
Input waveform	Sinusoidal (distortion factor 0.005)
Input frequency	50 or 60 Hz ±2%
Auxiliary supply voltage	Rated Value ±1%
Auxiliary supply frequency	Rated Value ±1%
Voltage Range	20... 100% of Nominal Value
Current Range	10... 100% of Nominal Value
Power	Cos phi / sin phi = 1 for Active / Reactive Power & Energy
	10... 100% of Nominal Current &
	20... 100% of Nominal Voltage
Power Factor / Phase Angle	40... 100% of Nominal Current &
	20... 100% of Nominal Voltage

### Accuracy:

Voltage	±1.0% of Nominal Value
Current	±1.0% of Nominal Value
Frequency	0.5% of mid frequency
Active Power	±1% of Nominal Value
Re-Active Power	±1% of Nominal Value
Apparent Power	±1% of Nominal Value.
Active Energy	± 1 %
Reactive Energy	± 1 %
Apparent Energy	± 1 %
Power Factor	2 % of Unity
Phase angle	2 % of range

Measurement error is normally much less than error specified above  
Variation due to influence quantity is less than twice the error allowed for reference condition

### Limit Switch (Relay):

Switching Voltage & Current for Relay	240 VDC, 5 A (1NO+1NC)
---------------------------------------	------------------------

### Influence of Variations:

Temperature coefficient: (for rated value range of use (0...50°C) 0.05%/°C for Current	0.025%/°C for Voltage
--	-----------------------

### Display update rate:

Response time to step input	1 sec approx.
-----------------------------	---------------

### Applicable Standards:

EMC Immunity	IEC 61326-1: 2012, Table 2
Safety	IEC 61010-1-2001 , Permanently connected use
IP for water & dust	IEC60529

### Safety:

Pollution degree:	2
Installation category:	III
High Voltage Test	4.7 kV DC, 50Hz for 1 minute between Aux. and measuring inputs

### Environmental:

Operating temperature	0 to +50°C
Storage temperature	-25°C to +70°C
Relative humidity	0... 90% non condensing
Warm up time	Minimum 3 minute
Shock	15g in 3 planes
Vibration	10... 55 Hz, 0.15mm amplitude

### Enclosure:

Front	IP 50
Back	IP 20

## Technical Specifications

### Dimensions and Weights:

Bezel size	96 mm x 96 mm DIN 43 718.
Panel cut-out	92 +0.8 mm x 92 + 0.8 mm.
Overall depth	55 mm.(without output option)
Panel Thickness	1 - 3 mm for self clicking, 1 - 6 mm for swivel screws
Weight	320 gm. Approx.(with output option)

### Pulsed Output Option:

#### Energy (can be programmed for different energy parameters simultaneously):

Relay contact	(1NO+1NC)
Switching Voltage & current for Relay	240 VDC, 5 A

Default pulse rate divisor	1 per Wh (up to 3600W),	1 per kWh (up to 3600kWh),	1 per MWh (above 3600kW),
Other Pulse rate divisors (applicable only when Energy on RS485 is in W)			
10	1 per 10 Wh (up to 3600W),	1 per 10 kWh (up to 3600kWh),	1 per 10 kWh (up to 3600kWh),
100	1 per 100 Wh (up to 3600W),	1 per 100 kWh (up to 3600kWh),	1 per 100 kWh (up to 3600kWh),
1000	1 per 1000 Wh (up to 3600W),	1 per 1000 kWh (up to 3600kWh),	1 per 1000 kWh (up to 3600kWh),

Pulse Duration : 60 msec, 100 msec, 200 msec.

Above options are also applicable to Apparent and Reactive Energy.

## Parameter Measurement and Display:

Sr No	Displayed Parameters	3Phase 4Wire	3Phase 3Wire	1Phase 2Wire	Split Phase
1.	System Voltage	✓	✓	✓	✓
2.	System Current	✓	✓	✓	✓
3.	Voltage L1	✓	✗	✓	✓
4.	Voltage L2	✓	✗	✗	✓
5.	Voltage L3	✓	✗	✗	✗
6.	Voltage L1 - L2	✓	✓	✗	✓
7.	Voltage L2 - L3	✓	✓	✗	✗
8.	Voltage L3 - L1	✓	✓	✗	✗
9.	Current L1	✓	✓	✓	✓
10.	Current L2	✓	✓	✗	✓
11.	Current L3	✓	✓	✗	✗
12.	Frequency	✓	✓	✓	✓
13.	System Active Power (kW)	✓	✓	✓	✓
14.	Active Power L1 (kW)	✓	✗	✓	✓
15.	Active Power L2 (kW)	✓	✗	✗	✓
16.	Active Power L3 (kW)	✓	✗	✗	✗
17.	System Re-active Power (kVAr)	✓	✓	✓	✓
18.	Re-active Power L1 (kVAr)	✓	✗	✓	✓
19.	Re-active Power L2 (kVAr)	✓	✗	✗	✓
20.	Re-active Power L3 (kVAr)	✓	✗	✗	✗
21.	System Apparent Power (kVA)	✓	✓	✓	✓
22.	Apparent Power L1 (kVA)	✓	✗	✓	✓
23.	Apparent Power L2 (kVA)	✓	✗	✗	✓
24.	Apparent Power L3 (kVA)	✓	✗	✗	✗
25.	System Power Factor	✓	✓	✓	✓
26.	Power Factor L1	✓	✗	✓	✓
27.	Power Factor L2	✓	✗	✗	✓
28.	Power Factor L3	✓	✗	✗	✗
29.	System Phase Angle	✓	✓	✓	✓
30.	Phase Angle L1	✓	✗	✓	✓

## Parameter Measurement and Display:

Sr No	Displayed Parameters	3Phase 4Wire	3Phase 3Wire	1Phase 2Wire	Split Phase
31.	Phase Angle L2	✓	✗	✗	✓
32.	Phase Angle L3	✓	✗	✗	✗
33.	Active Energy Import	✓	✓	✓	✓
34.	Active Energy Export	✓	✓	✓	✓
35.	Re-Active Energy Import	✓	✓	✓	✓
36.	Re-Active Energy Export	✓	✓	✓	✓
37.	Apparent Energy	✓	✓	✓	✓
38.	RPM	✓	✓	✓	✓
39.	Max SYS Voltage/ SYS Current	✓	✓	✓	✓
40.	Min SYS Voltage/ SYS Current	✓	✓	✓	✓
41.	Run Hour	✓	✓	✓	✓
42.	On Hour	✓	✓	✓	✓
43.	No. of Interruption	✓	✓	✓	✓
44.	Current Demand	✓	✓	✓	✓
45.	KVA Demand	✓	✓	✓	✓
46.	KW Demand Import	✓	✓	✓	✓
47.	KW Demand Export	✓	✓	✓	✓
48.	Max Current Demand	✓	✓	✓	✓
49.	Max KVA Demand	✓	✓	✓	✓
50.	Max KW Demand Import	✓	✓	✓	✓
51.	Max KW Demand Export	✓	✓	✓	✓

## Electrical Connections:

	Self Powered Aux	External Powered Aux
<b>3 Phase 4 Wire Unbalanced Load</b>		
<b>3 Phase 3 Wire Unbalanced Load</b>	Not Applicable	
<b>1 Phase 2 Wire</b>		

## Electrical Connections:

### Self Powered Aux

1 Phase  
3 Wire  
Split  
Phase

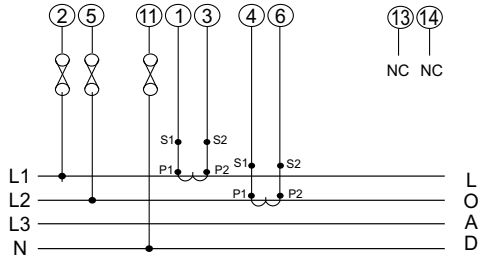

### External Powered Aux

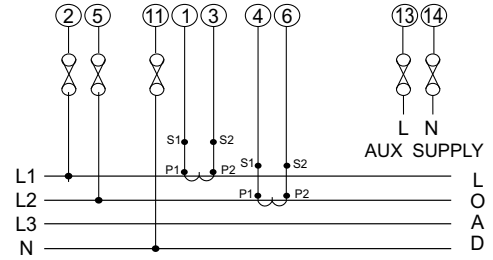

## Rear Connection

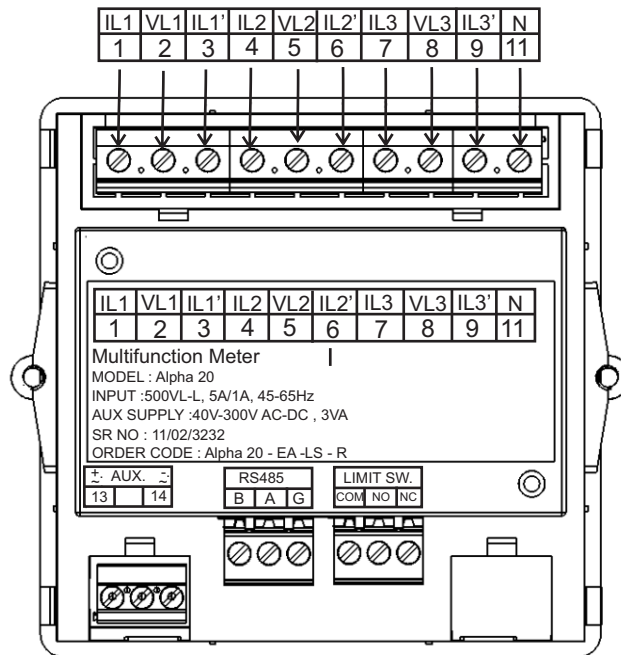

## Installation:

### Easy Clip in Installation on Panel.

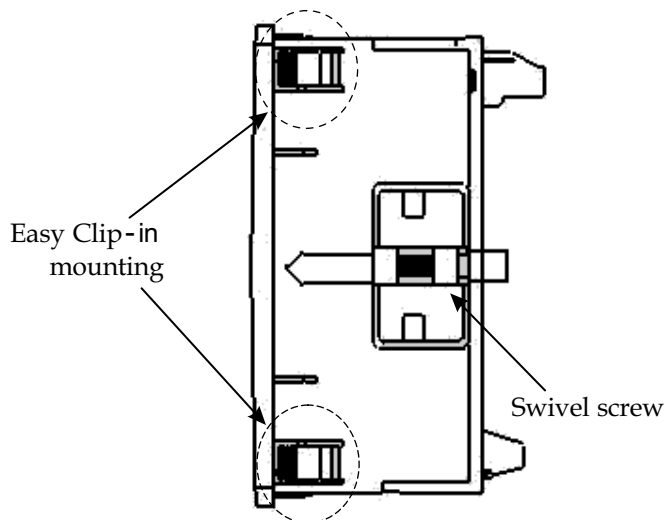

Panel Thickness : 1 - 3 mm for self clicking,  
1 - 6 mm for swivel screws.

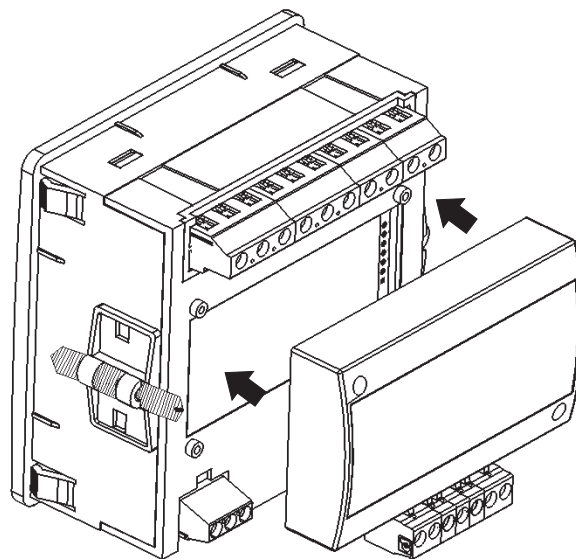

Optional Limit Switch pluggable module.

## Dimension Details:

With optional MODBUS / Limit switch .

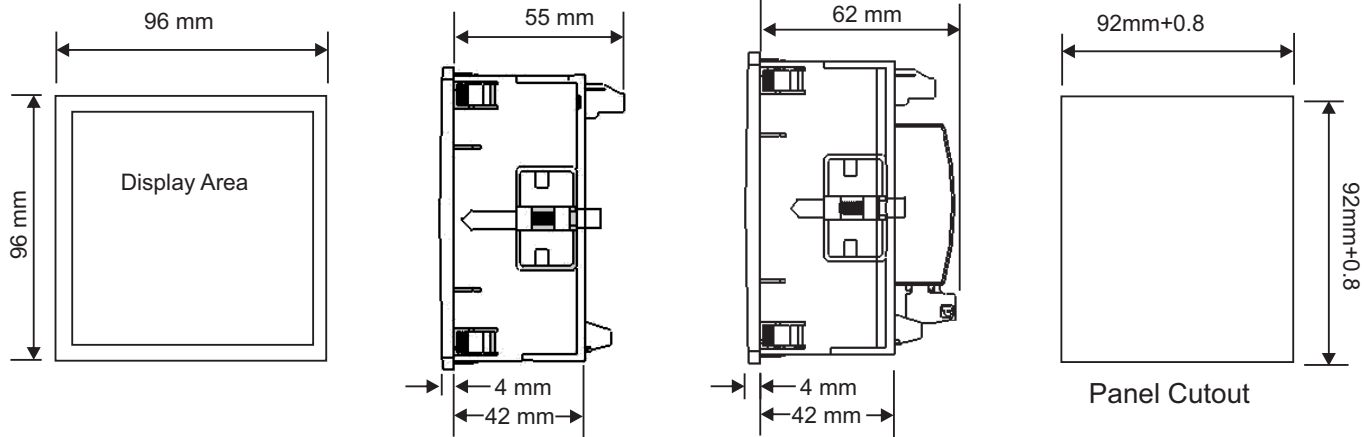

## Ordering information

Product Code	AP20-	X	X	X	XX	X	X	000000
System Type * System Type is Site selectable	3 Ph. or 1Ph	3						
Input Voltage	100 TO 500VL-L		1					
Input Current	5A/1A			1				
Power Supply	Self Aux 40-300U 12-48D				SA EA LA			
Limit switch	With Limit switch W/O Limit switch					L Z		
RS 485	With RS 485 Without RS 485						R Z	

### Order Code Example:

Alpha 20 Energy- EA - LS - R

Alpha 20 Energy, external aux (40V - 300V AC/DC), with limit switch, with MODBUS output.

**\*NOTE:** Self Auxiliary meter is available only in 3Phase 4 Wire and Single Phase network.

Auxiliary input is derived from Phase 1 (R phase).

In case of external auxiliary meter all three networks are available

(3Phase 4Wire / 3Phase 3Wire / 1Phase 3Wire / Single Phase)

Sifam Tinsley always tries for innovation and therefore product specifications are subject to change without notice



**Sifam Tinsley Instrumentation Inc.**  
2105 Barrett Park Drive, Unit 105  
Kennesaw, GA 30144 (USA)  
**E-mail Id :** psk@sifamtinsley.com  
**Web :** www.sifamtinsley.com  
**Contact No. :** +1 678 881 0008 /  
800 879 6171

**Sifam Tinsley Instrumentation Ltd**  
Unit 1 Warner Drive,  
Springwood Industrial Estate  
Braintree, Essex, UK, CM72YW  
**E-mail:** sales@sifamtinsley.com  
**Web:** www.sifamtinsley.com/uk  
**Contact:** +44(0)1803615139