

# Application Note

3105 Creekside Village Dr, Unit 801,  
Kennesaw, GA 30144

**Tel.:** 800-879-6171

**Email:** [info@sifamtinsley.com](mailto:info@sifamtinsley.com)

**Using Multifunction Meters with Modbus RS485  
Communication for Data Extraction**

## Overview

Analysis of electrical parameters is necessary in order to improve the efficiency of energy, energy conservation and to prevent adverse effects of power outage, short circuits, and other faults over an electrical installation. A multifunction meter is installed in commercial buildings, residential complexes and in industries to measure all important electrical parameters. A framework is defined to identify the strategies for monitoring and interpreting data in order to implement a smart environment.

## Problem Statement

The monitoring system for energy consumption consists of the monitoring electrical power system, environment monitoring and HVAC monitoring. Every monitoring system involves techniques like data collection, communication, etc. all of these to acquire data on real-time basis. It is essential to extract data as the first step of data analysis. For this, a proper and reliable mode of communication is required.

## Introducing RS485 communication

RS485 communication is one of the most optimal modes of communication for networking, even above Ethernet. The RS-485 Modbus enabled meters (and most other slave devices) is referred to as a “two wire” half-duplex communication (vs. “four wire” full-duplex). A half-duplex, two-wire bus requires fewer signal conductors, allowing one device to transmit data at any given time. In order to avoid ground interferences, a third wire – ground is connected at times.

The master initiates communication by issuing a command frame (or message) addressed to a specific slave. The slave with the matching unique address then responds either with requested register data or by registering the write operation. The first byte of each frame is the address of the slave device. The second byte is the command or function code. The subsequent bytes vary depending on the type of command and the last two bytes are the CRC (Cyclic Redundancy Check) value for verifying that the frame is valid. It allows communication of a total 32 devices including the master device without the use of a repeater.

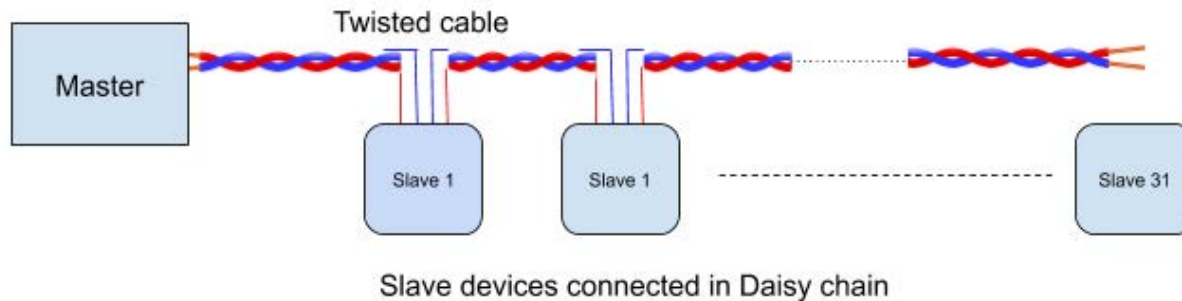

**Fig. 1. Master – Slave devices connected for RS485 Configuration**

## **Solution**

Multifunction meter installed in an electrical system (panel) of a residential or commercial building measures the various electrical parameters like voltage, current, frequency, power, power factor and energy consumed of all three phases. These parameters are then transmitted to the central system using the RS485 facility.

Sifam Tinsley offers the following range of multifunction meters with optional RS485 communication:

- EM Series
- Delta Energy
- Master series
- LM 13xx
- Power Quality devices

- These meters act as slaves and on the other end communication wire, a master device (PC) is connected through a RS485 to USB converter.
- The data transferred through a modbus RS485 network is connected to the centralized system for e.g. SCADA
- The data can then be viewed over a compatible software. The data can be according to time period viz. daily, weekly, monthly, etc
- It can also be written on a server location and can be retrieved for future reference.
- Thus, data analytics can be done on this data to prevent future mishaps, understand the pattern of electrical consumption, and also to improve it.



This document contains confidential information that is proprietary to Sifam Tinsley. Neither the document nor the information contained therein should be reproduced in whole or in part, without express written consent of Sifam Tinsley.